



COMUNICACIONES

SECRETARÍA DE INFRAESTRUCTURA, COMUNICACIONES Y TRANSPORTES



AFAC

AGENCIA FEDERAL DE AVIACIÓN CIVIL

(AFAC-2020-290-018-E; 10352/22)

Agencia Federal de Aviación Civil

Dirección Ejecutiva de Aviación

Dirección de Aviación

4.1.4. OPS.-10352/ 2022.

Ciudad de México, a 10 de noviembre de 2022

Asunto: Rev 10 SOP

Link Conexión Aérea, S.A. de C.V.

Blvd. Bernardo Quintana CS 9800,
Piso 7-B706, Centro Sur
C.P. 76090, Querétaro, Qro.

Ing. Gustavo Villafuerte Arredondo
Representante Legal

En atención a su escrito con referencia TAR-100/22 de fecha 09 de agosto del año en curso, y de acuerdo a lo establecido en el Reglamento de la Ley de Aviación Civil y las Normas Oficiales Mexicanas en vigor, así como en lo establecido en los transitorios Cuarto y Quinto del Decreto por el que se crea el órgano administrativo desconcentrado de la Secretaría de Infraestructura, Comunicaciones y Transportes, denominado Agencia Federal de Aviación Civil se devuelven debidamente aprobadas las siguientes enmiendas aplicables a las aeronaves Embraer, modelo EMB-145, no teniendo inconveniente en su uso operacional:

Manual / Número de Parte	Revisión	Fecha	Aplica para las series
Standard Operating Procedures Manual (SOP-145/1489)	10	08-agosto-2022	145063, 145067, 145080, 145078, 145071, 145481 y 145241

Dichas enmiendas deberán ser insertadas en el manual de vuelo con número de autorización **AUT. VLO.: 219/2013, de fecha 21 de octubre de 2013.**

Una copia en electrónico (CD) del manual queda en poder del archivo de ésta Dirección, debiendo entregar la copia anexa al presente a la Comandancia de su base de operaciones, para mantener actualizado el Manual correspondiente en poder de dicha Comandancia de Aeropuerto.

Atentamente.

Ing. Pablo Carranza Plata
Director Ejecutivo de Aviación



Cc. Director General de la Agencia Federal de Aviación Civil.- Pte.
Director Ejecutivo de Seguridad Aérea.- Pte.
Comandancia Regional III Monterrey - Apto. Inter. De la C.D., de Guadalajara – Terminal-II, C.P. 45659, Gdl., Jal.- Pte.
Comandante del Apto. "Intercontinental de Querétaro" – Km. 22.5, Municipio Colon, c.p. 76270, Querétaro, Qro.- Pte.

JACC*JALA*GAMA*AEB*
\\310jrobertoh0101\RAI\2\01_NAC\LINK CONEXIÓN AÉREA S.A. DE C.V\2022\10352-22 OF APROB Rev 10 Standard Operating Procedures Manual.docx

Boulevard Adolfo López Mateos 1990, Colonia Los Alpes, C. P. 01010, Alcaldía Álvaro Obregón, CDMX.
T: (55) 5723 9300 www.gob.mx/afac



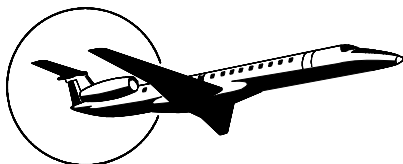

STANDARD OPERATING PROCEDURES MANUAL

EMBRAER S.A.

THIS MANUAL IS APPLICABLE TO ALL EMB-145 AND
EMB-135 AIRPLANES OPERATING UNDER ANAC, FAA
AND EASA CERTIFICATIONS.

SOP-145/1489

DECEMBER 14, 2007

REVISION 10 – AUGUST 08, 2022

In connection with the use of this document, Embraer does not provide any express or implied warranties and expressly disclaims any warranty of merchantability or fitness for a particular purpose. This document contains trade secrets, confidential, proprietary information of Embraer and technical data subject to U.S. Export Administration Regulation ("EAR") and other countries export control laws and regulations. Diversion contrary to the EAR and other laws and regulations is strictly forbidden. The above restrictions may apply to data on all pages of this document.

Copyright © 2022 by Embraer S.A. All rights reserved.



CUSTOMER COMMENT FORM

Standard Operating Procedures Manual SOP - 145/1489

Please use this Customer Comment Form to notify us of any discrepancies or problems you find in the Standard Operating Procedures. We would also welcome constructive suggestions on how we can further improve our documentation or service.

Your feedback will be acknowledged, and we will advise you of the action we intend to take.

Sincerely,
Embraer Flight Operations Support

Please return this form to:

Embraer - VOC/DSS/GEO - PC176
Av. Brigadeiro Faria Lima, 2170
CEP 12227-901
São José dos Campos - SP - BRASIL

Phone: +55 12 3927-1706
E-mail: opereng@embraer.com.br

HIGHLIGHTS OF CHANGE

The changes in this document are recognized by a vertical bar on the edge of the page matching with the changed lines. This bar will reflect the document revision number located at the bottom of each page.

Here are presented the summary of these changes.

REVISION 10 – AUGUST 08, 2022

Block	Page	Change Description
1-05	2	Added information regarding the operation with FMS version 6.1.1 (LPV and VNAV).
2-00	1	
2-07	5	
2-17	12	
2-33	2	
2-35	1	
2-37	1	
3-00	4, 5, 6, 7	
3-20	1, 2, 3, 4, 5, 6	
3-30	4, 5, 6, 7, 8, 9	
3-35-01	13, 14, 15, 16, 17, 18, 19	
3-35-10	1, 2, 3, 4, 5, 7, 8, 9, 10, 11, 24, 25, 27	



INTENTIONALLY BLANK

HO�	Page 2	Code 01
-----	-----------	------------

Copyright © by Embraer. Refer to cover page for details.

REVISION 10

SOP-145/1489

User: aherrera - Printed By myTechCare - Aug 09/22 - 14:17:22

LIST OF EFFECTIVE PAGES

ORIGINAL	0	DEC 14, 2007
REVISION	1	OCT 30, 2009
REVISION	2	OCT 22, 2012
REVISION	3	OCT 03, 2013
REVISION	4	MAR 06, 2015
REVISION	5	DEC 04, 2015
REVISION	6	APR 05, 2017
REVISION	7	MAR 26, 2018
REVISION	8	APR 26, 2019
REVISION	9	AUG 14, 2020
REVISION	10	AUG 08, 2022

* Title	REVISION 10	2-00-2	REVISION 4
		2-07-1	REVISION 4
* HOC-1	REVISION 10	2-07-2	REVISION 4
* HOC-2	REVISION 10	2-07-3	REVISION 5
		2-07-4	REVISION 6
* A	REVISION 10	* 2-07-5	REVISION 10
* B	REVISION 10	2-07-6	REVISION 8
* C	REVISION 10	2-09-1	REVISION 4
* D	REVISION 10	2-09-2	REVISION 4
* E	REVISION 10	2-09-3	REVISION 4
* F	REVISION 10	2-09-4	REVISION 4
		2-13-1	REVISION 4
TOC-1	REVISION 4	2-13-2	REVISION 4
TOC-2	REVISION 4	2-13-3	REVISION 4
		2-13-4	REVISION 4
1-00-1	REVISION 8	2-15-1	REVISION 4
1-00-2	REVISION 8	2-15-2	REVISION 8
1-05-1	REVISION 8	2-15-3	REVISION 4
* 1-05-2	REVISION 10	2-15-4	REVISION 8
		2-15-5	REVISION 8
* 2-00-1	REVISION 10	2-15-6	REVISION 4

* Asterisk indicates pages revised, added or deleted by the current revision.

REVISION 10

LEP	Page A	Code 01
-----	-----------	------------

2-15-7.....REVISION 8	* 2-37-1REVISION 10
2-15-8.....REVISION 4	* 2-37-2REVISION 10
2-17-1.....REVISION 8	2-41-1REVISION 8
2-17-2.....REVISION 8	2-41-2REVISION 8
2-17-3.....REVISION 8	2-42-1REVISION 4
2-17-4.....REVISION 8	2-42-2REVISION 4
2-17-5.....REVISION 8	2-45-1REVISION 4
2-17-6.....REVISION 8	2-45-2REVISION 4
2-17-7.....REVISION 8	2-49-1REVISION 8
2-17-8.....REVISION 8	2-49-2REVISION 8
2-17-9.....REVISION 8	2-49-3REVISION 8
2-17-10.....REVISION 8	2-49-4REVISION 8
2-17-11.....REVISION 8	2-53-1REVISION 8
* 2-17-12.....REVISION 10	2-53-2REVISION 8
* 2-17-13.....REVISION 10	2-63-1REVISION 6
* 2-17-14.....REVISION 10	2-63-2REVISION 4
* 2-17-15.....REVISION 10	2-65-1REVISION 4
* 2-17-16.....REVISION 10	2-65-2REVISION 9
* 2-17-17.....REVISION 10	2-70-1REVISION 4
* 2-17-18.....REVISION 10	2-70-2REVISION 4
* 2-17-19.....REVISION 10	2-71-1REVISION 8
* 2-17-20.....REVISION 10	2-71-2REVISION 8
2-25-1.....REVISION 8	2-75-1REVISION 4
2-25-2.....REVISION 8	2-75-2REVISION 8
2-25-3.....REVISION 9	2-75-3REVISION 8
2-25-4.....REVISION 8	2-75-4REVISION 8
2-29-1.....REVISION 9	2-75-5REVISION 4
2-29-2.....REVISION 9	2-75-6REVISION 4
2-31-1.....REVISION 5	2-75-7REVISION 4
2-31-2.....REVISION 5	2-75-8REVISION 4
2-33-1.....REVISION 8	2-75-9REVISION 4
* 2-33-2.....REVISION 10	2-75-10REVISION 4
* 2-33-3.....REVISION 10	2-75-11REVISION 4
* 2-33-4.....REVISION 10	2-75-12REVISION 5
2-34-1.....REVISION 5	2-75-13REVISION 5
2-34-2.....REVISION 4	2-75-14REVISION 4
* 2-35-1.....REVISION 10	2-75-15REVISION 4
2-35-2.....REVISION 8	2-75-16REVISION 4
2-35-3.....REVISION 8	2-75-17REVISION 4
2-35-4.....REVISION 8	2-75-18REVISION 4

* Asterisk indicates pages revised, added or deleted by the current revision.

LEP	Page B	Code 01
-----	-----------	------------

REVISION 10

2-75-19 REVISION 6	3-05-10-4 REVISION 4
2-75-20 REVISION 4	3-05-10-5 REVISION 4
2-77-1 REVISION 4	3-05-10-6 REVISION 4
2-77-2 REVISION 4	3-05-10-7 REVISION 4
2-77-3 REVISION 4	3-05-10-8 REVISION 4
2-77-4 REVISION 4	3-05-10-9 REVISION 4
2-80-1 REVISION 4	3-05-10-10 REVISION 4
2-80-2 REVISION 4	3-05-10-11 REVISION 5
2-83-1 REVISION 9	3-05-10-12 REVISION 4
2-83-2 REVISION 4	3-10-1 REVISION 5
	3-10-2 REVISION 8
3-00-1 REVISION 4	3-10-3 REVISION 4
3-00-2 REVISION 4	3-10-4 REVISION 4
3-00-3 REVISION 4	3-10-5 REVISION 4
* 3-00-4 REVISION 10	3-10-6 REVISION 4
* 3-00-5 REVISION 10	3-10-7 REVISION 4
* 3-00-6 REVISION 10	3-10-8 REVISION 8
* 3-00-7 REVISION 10	3-10-9 REVISION 4
* 3-00-8 REVISION 10	3-10-10 REVISION 4
3-05-01-1 REVISION 5	3-10-11 REVISION 4
3-05-01-2 REVISION 5	3-10-12 REVISION 4
3-05-01-3 REVISION 5	3-10-13 REVISION 4
3-05-01-4 REVISION 5	3-10-14 REVISION 4
3-05-01-5 REVISION 5	3-10-15 REVISION 4
3-05-01-6 REVISION 5	3-10-16 REVISION 4
3-05-01-7 REVISION 5	3-10-17 REVISION 4
3-05-01-8 REVISION 4	3-10-18 REVISION 4
3-05-01-9 REVISION 4	3-10-19 REVISION 4
3-05-01-10 REVISION 4	3-10-20 REVISION 4
3-05-05-1 REVISION 4	3-10-21 REVISION 6
3-05-05-2 REVISION 4	3-10-22 REVISION 6
3-05-05-3 REVISION 4	3-15-01-1 REVISION 4
3-05-05-4 REVISION 5	3-15-01-2 REVISION 6
3-05-05-5 REVISION 5	3-15-01-3 REVISION 4
3-05-05-6 REVISION 4	3-15-01-4 REVISION 4
3-05-05-7 REVISION 4	3-15-01-5 REVISION 4
3-05-05-8 REVISION 4	3-15-01-6 REVISION 4
3-05-10-1 REVISION 4	3-15-01-7 REVISION 4
3-05-10-2 REVISION 4	3-15-01-8 REVISION 5
3-05-10-3 REVISION 4	3-15-05-1 REVISION 4

* Asterisk indicates pages revised, added or deleted by the current revision.

REVISION 10

LEP	Page C	Code 01
-----	-----------	------------

3-15-05-2	REVISION 4	3-25-4	REVISION 5
3-15-05-3	REVISION 4	3-25-5	REVISION 5
3-15-05-4	REVISION 4	3-25-6	REVISION 5
3-15-05-5	REVISION 4	3-25-7	REVISION 5
3-15-05-6	REVISION 4	3-25-8	REVISION 5
3-15-05-7	REVISION 4	3-25-9	REVISION 5
3-15-05-8	REVISION 4	3-25-10	REVISION 5
3-15-05-9	REVISION 4	3-25-11	REVISION 5
3-15-05-10	REVISION 4	3-25-12	REVISION 5
3-15-05-11	REVISION 9	3-25-13	REVISION 5
3-15-05-12	REVISION 4	3-25-14	REVISION 5
3-15-10-1	REVISION 4	3-25-15	REVISION 7
3-15-10-2	REVISION 8	3-25-16	REVISION 5
3-15-10-3	REVISION 4	3-25-17	REVISION 5
3-15-10-4	REVISION 4	3-25-18	REVISION 9
3-15-10-5	REVISION 4	3-25-19	REVISION 9
3-15-10-6	REVISION 4	3-25-20	REVISION 9
3-15-10-7	REVISION 5	3-25-21	REVISION 9
3-15-10-8	REVISION 5	3-25-22	REVISION 9
3-15-10-9	REVISION 4	3-25-23	REVISION 9
3-15-10-10	REVISION 4	3-25-24	REVISION 9
3-15-10-11	REVISION 4	3-25-25	REVISION 9
3-15-10-12	REVISION 4	3-25-26	REVISION 9
3-15-10-13	REVISION 4	3-25-27	REVISION 9
3-15-10-14	REVISION 4	3-25-28	REVISION 9
3-15-10-15	REVISION 5	3-30-1	REVISION 6
3-15-10-16	REVISION 5	3-30-2	REVISION 5
* 3-20-1	REVISION 10	* 3-30-3	REVISION 10
* 3-20-2	REVISION 10	* 3-30-4	REVISION 10
* 3-20-3	REVISION 10	* 3-30-5	REVISION 10
* 3-20-4	REVISION 10	* 3-30-6	REVISION 10
* 3-20-5	REVISION 10	* 3-30-7	REVISION 10
* 3-20-6	REVISION 10	* 3-30-8	REVISION 10
* 3-20-7	REVISION 10	* 3-30-9	REVISION 10
* 3-20-8	REVISION 10	* 3-30-10	REVISION 10
* 3-20-9	REVISION 10	3-32-1	REVISION 6
* 3-20-10	REVISION 10	3-32-2	REVISION 5
3-25-1	REVISION 4	3-32-3	REVISION 5
3-25-2	REVISION 4	3-32-4	REVISION 5
3-25-3	REVISION 5	3-35-01-1	REVISION 6

* Asterisk indicates pages revised, added or deleted by the current revision.

LEP	Page D	Code 01
-----	-----------	------------

REVISION 10

3-35-01-2 REVISION 4	3-35-05-12 REVISION 4
3-35-01-3 REVISION 5	* 3-35-10-1 REVISION 10
3-35-01-4 REVISION 5	* 3-35-10-2 REVISION 10
3-35-01-5 REVISION 4	* 3-35-10-3 REVISION 10
3-35-01-6 REVISION 5	* 3-35-10-4 REVISION 10
3-35-01-7 REVISION 5	* 3-35-10-5 REVISION 10
3-35-01-8 REVISION 5	* 3-35-10-6 REVISION 10
3-35-01-9 REVISION 5	* 3-35-10-7 REVISION 10
3-35-01-10 REVISION 5	* 3-35-10-8 REVISION 10
3-35-01-11 REVISION 6	* 3-35-10-9 REVISION 10
3-35-01-12 REVISION 5	* 3-35-10-10... REVISION 10
* 3-35-01-13 ... REVISION 10	* 3-35-10-11... REVISION 10
* 3-35-01-14 ... REVISION 10	* 3-35-10-12... REVISION 10
* 3-35-01-15 ... REVISION 10	* 3-35-10-13... REVISION 10
* 3-35-01-16 ... REVISION 10	* 3-35-10-14... REVISION 10
* 3-35-01-17 ... REVISION 10	* 3-35-10-15... REVISION 10
* 3-35-01-18 ... REVISION 10	* 3-35-10-16... REVISION 10
* 3-35-01-19 ... REVISION 10	* 3-35-10-17... REVISION 10
* 3-35-01-20 ... REVISION 10	* 3-35-10-18... REVISION 10
* 3-35-01-21 ... REVISION 10	* 3-35-10-19... REVISION 10
* 3-35-01-22 ... REVISION 10	* 3-35-10-20... REVISION 10
* 3-35-01-23 ... REVISION 10	* 3-35-10-21... REVISION 10
* 3-35-01-24 ... REVISION 10	* 3-35-10-22... REVISION 10
* 3-35-01-25 ... REVISION 10	* 3-35-10-23... REVISION 10
* 3-35-01-26 ... REVISION 10	* 3-35-10-24... REVISION 10
* 3-35-01-27 ... REVISION 10	* 3-35-10-25... REVISION 10
* 3-35-01-28 ... REVISION 10	* 3-35-10-26... REVISION 10
* 3-35-01-29 ... REVISION 10	* 3-35-10-27... REVISION 10
* 3-35-01-30 ... REVISION 10	* 3-35-10-28... REVISION 10
3-35-05-1 REVISION 5	* 3-35-10-29... REVISION 10
3-35-05-2 REVISION 4	* 3-35-10-30... REVISION 10
3-35-05-3 REVISION 4	3-40-1 REVISION 4
3-35-05-4 REVISION 4	3-40-2 REVISION 4
3-35-05-5 REVISION 4	3-40-3 REVISION 4
3-35-05-6 REVISION 4	3-40-4 REVISION 4
3-35-05-7 REVISION 4	3-40-5 REVISION 4
3-35-05-8 REVISION 5	3-40-6 REVISION 4
3-35-05-9 REVISION 4	3-40-7 REVISION 4
3-35-05-10 REVISION 4	3-40-8 REVISION 4
3-35-05-11 REVISION 4	3-40-9 REVISION 4

* Asterisk indicates pages revised, added or deleted by the current revision.

LEP	Page E	Code 01
-----	-----------	------------

3-40-10.....REVISION 4
3-40-11.....REVISION 9
3-40-12.....REVISION 9
3-40-13.....REVISION 9
3-40-14.....REVISION 9
3-40-15.....REVISION 9
3-40-16.....REVISION 9
3-40-17.....REVISION 9
3-40-18.....REVISION 9
3-40-19.....REVISION 9
3-40-20.....REVISION 9
3-40-21.....REVISION 9
3-40-22.....REVISION 9
3-40-23.....REVISION 9
3-40-24.....REVISION 9
3-40-25.....REVISION 9
3-40-26.....REVISION 9
3-40-27.....REVISION 9
3-40-28.....REVISION 9
3-40-29.....REVISION 9
3-40-30.....REVISION 9

User: aherrera - Printed By myTechCare - Aug 09/22 - 14:17:22

* Asterisk indicates pages revised, added or deleted by the current revision.

LEP	Page F	Code 01
-----	-----------	------------

REVISION 10

TABLE OF CONTENTS

1. INTRODUCTION
2. NORMAL PROCEDURES
3. PROCEDURES AND TECHNIQUES

User: aherrera - Printed By myTechCare - Aug 09/22 - 14:17:22

SOP-145/1489

REVISION 4

TOC	Page 1	Code 01
-----	-----------	------------

INTENTIONALLY BLANK

TOC	Page 2	Code 01
-----	-----------	------------

Copyright © by Embraer. Refer to cover page for details.

REVISION 4

SOP-145/1489

User: aherrera - Printed By myTechCare - Aug 09/22 - 14:17:22

SECTION 1

INTRODUCTION

TABLE OF CONTENTS

	Block	Page
Introduction	1-05.....	01
Procedural Deviation and Its Relation to Safety	1-05.....	02
Airplane Sophistication and Checklists.....	1-05.....	02
Indentation	1-05.....	02

User: aherrera - Printed By myTechCare - Aug 09/22 - 14:17:22



INTENTIONALLY BLANK

User: aherrera - Printed By myTechCare - Aug 09/22 - 14:17:22

1-00	Page 2	Code 01
------	-----------	------------

Copyright © by Embraer. Refer to cover page for details.

REVISION 8

SOP-145/1489

INTRODUCTION

The SOP provides information and guidance for the efficient operation of the EMBRAER 145.

This manual is not a replacement of any of the operational manuals required by applicable regulations such as the Airplane Flight Manual or the Company Operations Manual.

This SOP is optimized for passenger-carrying operation in a commercial airline environment and the philosophy behind this manual is based on reducing crew workload while maintaining the highest possible level of safety.

Standard operating procedures are a set of procedures that serve to provide common ground for all crewmembers, usually unfamiliar with each other's experience and technical capabilities. In a well-standardized operation, another qualified pilot could replace an active cockpit crewmember during the flight, and the operation would continue safely and smoothly.

The **Normal Procedures** section presents the AFM/AOM Normal Procedures. The intention is to eliminate any doubts regarding Flight Standards that may occur during the operation of the airplane.

The **Procedures and Techniques** section brings operational practices and flight profiles to a standard cockpit concept throughout flight phases. It has directives related to how the operation should be conducted. Topics like Crew Coordination, Captain authority and Areas of responsibility are included.

It also contains guidelines to be observed should a specific situation arise regardless of when and where it occurs during the flight. Topics such as handling of the autopilot and task sharing when hand-flying the airplane are covered in those sections.

Information regarding Low Visibility standardizes the procedures under this scenario emphasizing the crew coordination and presents the configurations approved to perform the operation with low visibility divided in flight phases.

Emergency/Abnormal Procedures are also presented according to its flight phase in the **Procedures and Techniques** section. It is presented some AFM/AOM Emergency/Abnormal Procedures in a detailed manner. The intention is to guide the crew on how to perform the required tasks to correct a situation or condition. Only the QRH procedures requiring high level of crew coordination are presented.

PROCEDURAL DEVIATION AND ITS RELATION TO SAFETY

The highest percentage of problems that generate crew-caused accidents and incidents manifest themselves in the form of procedural deviation. If the flight goes well, these deviations are not perceived and in most cases are left unresolved but they become apparent following an incident or an accident.

AIRPLANE SOPHISTICATION AND CHECKLISTS

The degree of technological sophistication in the design of this family of airplanes directly affects the checklist. On older airplanes, the flight crew must manually select and monitor most items. In more advanced airplanes the same items are accomplished by automatic systems that relieve the flight crew of these tasks. Checklists for these airplanes tend to be shorter and simpler but require a more careful task analysis with improved monitoring skills.

This manual recommends, whenever applicable, the use of automated systems, in order to safely reduce crew workload. In this sense, the following airplane configuration is considered:

– Airplanes equipped only with LNAV.

The use of FMS and Autopilot are considered whenever possible. Flight Director or autothrottle alone are adopted when the other automated systems are unpractical.

INDENTATION

Indentation exists when the information is displaced to the right relative to the paragraph that immediately precedes it. The indentation is used to establish a relationship between the indented and the preceding information.

Indented information is normally preceded by a condition (e.g. “during landing”, “if something is true”, “when something happens”). When this is the case, observe the indented information when the preceding condition is satisfied.

1-05	Page 2	Code 01
------	-----------	------------

SECTION 2

NORMAL PROCEDURES

TABLE OF CONTENTS

	Block	Page
Normal Checklist.....	2-07	01
Internal Safety Inspection	2-09	01
Power Up	2-13	01
External Safety Inspection	2-15	01
Before Start.....	2-17	01
Engine Start	2-17	17
Abnormal Engine Start Indications	2-17	20
After Start.....	2-25	01
Before Takeoff	2-29	01
Takeoff	2-31	01
After Takeoff	2-33	01
Climb.....	2-34	01
Descent.....	2-35	01
Approach	2-37	01
Before Landing	2-41	01
Missed Approach	2-42	01
After Landing	2-45	01
Shutdown	2-49	01
Leaving the Airplane	2-53	01
Engine Start Assisted by the Opposite Engine (Cross Start)	2-63	01
Engine Start Assisted by the APU	2-63	02



Block Page

Engine Start with Airplane Batteries
and Low Pressure Unit (LPU)2-65 01

Single Engine Taxi2-70 01

Hot Weather2-71 01

Ice Conditions. Cold Weather and Cold Soak2-75 01

Lightning Strike2-77 01

Turbulent Air Penetration2-80 01

Windshear2-83 01

User: aherrera - Printed By myTechCare - Aug 09/22 - 14:17:22

2-00	Page 2	Code 01
------	-----------	------------

**NORMAL CHECKLIST
INTERNAL SAFETY INSPECTION**

CHALLENGE	ACTION	PERFORMED BY
Maintenance Status	CKD	LSP/RSP
Cockpit Emergency Equip	CKD	RSP
Reinforced Cockpit Door Vent Louver (if applicable)....	OPN	RSP
Circuit Breakers	CKD	RSP
ELECTRIC Panel.....	SET	RSP
Emergency Lights	OFF	RSP
Fire Extinguishing Handle 1.....	PUSHED IN.....	RSP
FUEL Panel	SET	RSP
ICU Panel	SET	RSP
Exterior Lights.....	SET	RSP
APU	OFF	RSP
Ignitions	AUTO	RSP
START/STOP Selectors	STOP	RSP
Fire Extinguishing Handle 2.....	PUSHED IN.....	RSP
Ailerons & Rudders Shutoff	PUSHED IN.....	RSP
HYDRAULIC Panel.....	SET	RSP
Windshield Heating.....	PUSHED OUT.....	RSP
Sensors	PUSHED IN.....	RSP
Ice Detection Override	AUTO	RSP
AIR COND/PNEUM Panel.....	SET	RSP
Windshield Wipers (if installed)	OFF	RSP
Lights	OFF	RSP
ELT	ARMED	RSP
Weather Radar	OFF	RSP
Landing Gear Lever	DOWN.....	RSP
Crew Oxygen	ON.....	RSP
PASSENGER OXYGEN Panel..	SET	RSP
Gust Lock	LOCKED	RSP
Speed Brake	CLSD.....	RSP
Emergency/Parking Brake.....	AS RQRD.....	RSP
FLAPS Selector Lever	VERIFY POS.....	RSP
Alternate Gear Extension Compartment.....	CKD.....	RSP

User: aherrera - Printed By myTechCare - Aug 09/22 - 14:17:22



POWER UP

CHALLENGE	ACTION	PERFORMED BY
Batteries 1 & 2	AUTO.....	RSP
Avionics Master 1 or 2	PUSHED IN	RSP
* Batteries Voltage.....	CKD	RSP
* Backup Battery (EMB XR only) .	CKD	RSP
GPU Voltage (if available).....	CKD	RSP
Avionics Master 1 & 2	PUSHED OUT	RSP
GPU (if available).....	PUSHED IN	RSP
Fuel Pump Power Tank 2	AS RQRD	RSP
Navigation Light	ON	RSP
* FIRE EXTINGUISHER Panel ...	CKD	RSP
APU.....	AS RQRD	RSP
Avionics Master 1 & 2	PUSHED IN	RSP
.....	With APU Power	
GPU (if available).....	PUSHED OUT	RSP
.....	3 minutes After APU Start	
APU Bleed	PUSHED IN	RSP
Air Conditioning.....	AS RQRD	RSP

User: aherrera - Printed By myTechCare - Aug 09/22 - 14:17:22

2-07	Page 2	Code 01
------	-----------	------------

BEFORE START

CHALLENGE	RESPONSE	ANSWERED BY
Manuals & Documents	ON BOARD.....	LSP
CVR	CKD	LSP
Electrical Panel	SET	LSP
Emergency Lights	ARM	LSP
Push Button Lights		
Test (if installed)	CKD	LSP
◆ Fuel Panel.....	SET	LSP
* Fire Detection	CKD	LSP
Fire Extinguisher Panel	CKD	LSP
Powerplant Panel.....	SET	LSP
* Elec Pump Sys 1 & 2	CKD	LSP
Elec Pump Sys 1 & 2	OFF.....	LSP
◆ Pax Signs Panel	SET	LSP
Ice Protection Panel	SET	LSP
AIR COND/PNEUM Panel.....	SET	LSP
Oxy Masks & Regulators	CKD	LSP/RSP
Weather Radar	TST/STBY.....	LSP/RSP
Pitch Trim Cutout Buttons.....	CKD	LSP
Display Control Panel	SET	LSP/RSP
◆ Flight Number & Clocks.....	SET	LSP
AHRS (if applicable)	SET	LSP/RSP
IRS (if applicable)	NAV	LSP/RSP
Autopilot.....	CKD	LSP/RSP
Gust Lock	LOCKED	LSP/RSP
Reversionary Panel	SET	LSP/RSP
◆ Flight Instruments	SET/X-CKD.....	LSP/RSP
◆ RMU	SET	LSP/RSP
Thrust Levers.....	IDLE	LSP
◆ Stall Protection System.....	CKD	LSP
Trim Panel	CKD	LSP
◆ Pressurization Panel.....	SET	LSP
◆ FMS	SET	LSP/RSP
.....
◆ Fuel QTY	CKD	LSP/RSP
◆ FMS	SET	LSP/RSP
◆ Speed Bugs	SET	LSP
◆ TRIM Panel.....	__SET/ZERO/ZERO.	LSP
◆ Doors & Windows	CLSD	LSP/RSP
◆ Takeoff Briefing	COMPLETED	LSP/RSP

User: aherrera - Printed By myTechCare - Aug 09/22 - 14:17:22

SOP-145/1489

REVISION 5

2-07	Page 3	Code 01
------	-----------	------------



CHALLENGE	RESPONSE	ANSWERED BY
◆ Fuel Pump Power	ON	LSP
◆ Red Beacon	ON	LSP
◆ Emergency/Parking Brake	AS RQRD	LSP
◆ Steering	AS RQRD	LSP
Safety Pins	ON BOARD	LSP

AFTER START

CHALLENGE	RESPONSE	ANSWERED BY
Ground Equipment.....	REMOVED	LSP
Electrical Panel	SET	LSP
APU.....	AS RQRD.....	LSP
FADEC.....	RST/ALTN.....	LSP
Elec Hyd Pumps	AUTO	LSP
Windshield Heating.....	AS RQRD.....	LSP
AIR COND/PNEUM Panel	SET	LSP
FLAPS.....	__SET	LSP
Flight Controls.....	CKD.....	LSP
Taxi Lights.....	ON.....	LSP

BEFORE TAKEOFF

CHALLENGE	RESPONSE	ANSWERED BY
Takeoff Briefing.....	PERFORM	LSP
Ice Protection Test.....	AS RQRD.....	LSP
Brakes Temperature	CKD.....	LSP
EICAS	CKD.....	LSP
Transponder	TA/RA.....	LSP
Takeoff Configuration	CKD.....	LSP
Gust Lock.....	UNLOCKED	LSP
Elevator.....	CKD.....	LSP

User: aherrera - Printed By myTechCare - Aug 09/22 - 14:17:22

AFTER TAKEOFF

CHALLENGE	RESPONSE	ANSWERED BY
Landing Gear	UP	PM
FLAPS	0	PM
Thrust Rating	CLB	PM
Windshield Heating	AS RQRD	PM
AIR COND/PNEUM Panel.....	SET	PM
Altimeters.....	SET/X-CKD.....	PM
Pressurization	CKD	PM
APU	AS RQRD	PM
VNAV (if applicable)	ENGAGED	PM

DESCENT

CHALLENGE	RESPONSE	ANSWERED BY
Approach Briefing	COMPLETED	PF
Windshield Heating	PUSHED IN	PM
Speed Bugs	SET	PM
PRESSURIZATION Panel.....	SET	PM

Pax Signs	SET	PM

APPROACH

CHALLENGE	RESPONSE	ANSWERED BY
PASS SIGNS Panel	SET	PM
Altimeters.....	SET/X-CKD.....	PF/PM
Approach Aids	SET/X-CKD.....	PF/PM

BEFORE LANDING

CHALLENGE	RESPONSE	ANSWERED BY
Landing Gear	DOWN	PF/PM
FLAPS	SET	PF/PM
Lights	AS RQRD	PM
AP/YD	OFF	PF

User: aherrera - Printed By myTechCare - Aug 09/22 - 14:17:22

SHUTDOWN

CHALLENGE	RESPONSE	ANSWERED BY
Thrust Levers	IDLE	LSP
Emergency/Parking Brake	SET	LSP
GPU/APU Generators.....	PUSHED IN	LSP
Shed Buses	AS RQRD.....	LSP
START/STOP Selectors	STOP	LSP
Red Beacon	OFF	LSP
FSTN BELTS	OFF	LSP
Fuel Pump Pwr	AS RQRD.....	LSP
Elec Hyd Pumps	OFF	LSP
Ice Protection Sys.....	OFF	LSP
AIR COND/PNEUM Panel.....	SET	LSP

LEAVING THE AIRPLANE

CHALLENGE	RESPONSE	ANSWERED BY
IRS (if applicable)	OFF	LSP
Avionics Master 1 & 2	PUSHED OUT	LSP
Emergency Lights	OFF	LSP
External & Internal Lights.....	OFF	LSP
Pax Signs Panel	OFF	LSP
Weather Radar	OFF	LSP/RSP
Standby Attitude (if applicable)	CAGED	LSP
GPU/APU.....	OFF	LSP
AIR COND/PNEUM Panel.....	SET	LSP
Fuel Pumps.....	OFF	LSP
Batteries.....	OFF	LSP

◆ **ON THROUGH FLIGHTS CHECKLITS.**

User: aherrera - Printed By myTechCare - Aug 09/22 - 14:17:22

2-07	Page 6	Code 01
------	-----------	------------

INTERNAL SAFETY INSPECTION

The Internal Safety Inspection procedures must be performed every crew's first flight of the day on a particular airplane.

CHALLENGE ACTION PERFORMED BY

Maintenance Status CHECK..... LSP&RSP

Cockpit Emergency Equipment..... CHECK.....RSP

Check for the availability, status and proper location of the following equipment:

- Escape ropes;
- Oxygen masks;
- Smoke goggles;
- Portable Breathing Equipment (PBE);
- Fire extinguishers;
- Crash axe;
- Flashlights;
- Life vests.

Reinforced Cockpit Door

Vent Louver (if applicable)..... OPEN.....RSP

Circuit Breakers CHECK.....RSP

Verify all circuit breakers IN at the overhead panel, behind the LSP seat and behind the RSP seat to ensure agreement with maintenance status.

ELECTRIC Panel SETRSP

- Generators..... PUSHED IN
- GPU PUSHED OUT
- APU GEN..... PUSHED IN
- BATT 1 & 2 OFF
- Essential Power GUARDED OUT
- Bus Ties & Shed Buses AUTO
- AC Power (if applicable) PUSHED IN
- Back-up..... PUSHED IN
- Avionics Master 1 & 2 PUSHED OUT

SOP-145/1489

REVISION 4

2-09	Page 1	Code 01
------	-----------	------------



CHALLENGE	ACTION	PERFORMED BY
Emergency Lights	OFF	RSP
Fire Extinguishing Handle 1	PUSHED IN	RSP
FUEL Panel	SET	RSP
Fuel Crossfeed	OFF	
Pump Power 1 & 2	OFF	
ICU Panel	PUSHED OUT	RSP
Exterior Lights	OFF	RSP
APU	SET	RSP
APU Fire Extinguishing	GUARDED OUT	
APU Master	OFF	
APU FUEL SHUTOFF	GUARDED OUT	
Ignitions	AUTO	RSP
START/STOP Selectors	STOP	RSP
Fire Extinguishing Handle 2	PUSHED IN	RSP
Ailerons & Rudders Shutoff	PUSHED IN	RSP
HYDRAULIC Panel	SET	RSP
Engine Pump Shutoff	GUARDED OUT	
Electric Hydraulic Pumps	OFF	
Windshield Heating	PUSHED OUT	RSP
Sensors	PUSHED IN	RSP
Ice Protection Buttons	PUSHED IN	RSP
Ice Detection Override Knob	AUTO	RSP
AIR COND/PNEUMATIC Panel	SET	RSP
Recirculation & Gasper	IN	
Packs 1 & 2	PUSHED OUT	
Engine & APU Bleed	PUSHED OUT	

2-09	Page 2	Code 01
------	-----------	------------

CHALLENGE	ACTION	PERFORMED BY
Windshield Wipers (if installed)	OFF	RSP
Lights	OFF	RSP
ELT	ARMED	RSP
Weather Radar	OFF	RSP
Landing Gear Lever	DOWN	RSP
Crew Oxygen	ON	RSP
PASSENGER OXYGEN Panel	SET	RSP
Verify Masks Deploy Selector Knob in AUTO.		
Gust Lock	LOCKED	RSP
Speed Brake	CLOSED	RSP
Emergency/Parking Brake	AS REQUIRED	RSP

If the airplane is to be pushed back for start and if start is to be performed with the APU, the crew may leave the parking brake released as long as the chocks are in place.

NOTE: To prevent hydraulic fluid transfer between systems: To apply the parking brake first press the brake pedals to full deflection, then pull the emergency/parking brake handle. To release the parking brake, first press the brake pedals to full deflection then release the emergency/parking brake handle.

FLAPS Selector Lever **VERIFY POSITION** **RSP**

Verify and make sure that the actual FLAPS Selector lever position agrees with the surface position.

CAUTION: NEVER MOVE CONTROL SURFACES SUCH AS FLAPS AND SPOILERS WITHOUT FIRST MAKING SURE THAT THE AREA IS CLEAR.

Alternate Gear Extension

Compartment **CHECK** **RSP**

Verify the alternate gear extension lever is fully down and the electrical override switch is in the "NORMAL" position.

SOP-145/1489

REVISION 4

2-09	Page 3	Code 01
------	-----------	------------



INTENTIONALLY BLANK

User: aherrera - Printed By myTechCare - Aug 09/22 - 14:17:22

2-09	Page 4	Code 01
------	-----------	------------

Copyright © by Embraer. Refer to cover page for details.

REVISION 4

SOP-145/1489

POWER UP

The POWER UP procedures and checklist must be performed every crew's first flight of the day on a particular airplane or when a power down was required.

If receiving the airplane already powered up, verify compliance with all items and perform FIRE EXTINGUISHER Panel Test.

CHALLENGE	ACTION	PERFORMED BY
Batteries 1 & 2	AUTO	RSP

Immediately after the batteries are switched ON the aural message "AURAL UNIT OK" should be heard.

Avionics Master 1 or 2	PUSHED IN	RSP
-------------------------------------	------------------------	------------

* Batteries Voltage	CHECKED	RSP
----------------------------------	----------------------	------------

Check battery voltage on MFD.

If battery voltage is below 19 V it must be replaced. If battery voltage is below 24 V report to the maintenance personnel or recharge the affected battery by using the APU generator. In case of recharging, it is recommended that battery 1 be turned OFF before APU start. After APU start wait 3 minutes then select battery 1 to AUTO.

The minimum time for battery recharging is 30 minutes.

For cold soak operation, refer to AOM section 1-02-79 – "Operation In Icing Conditions".

Once the batteries are on, the pilot must concentrate on starting up the APU shortly, so as to save the batteries. Avoid, for example, taking time to adjust the seat or to look at documents. Plan to do these things after starting the APU and its generator is on.

* Backup Battery (EMB-145 XR only)	CHECKED	RSP
---	----------------------	------------

Release the Backup Battery Button momentarily and check if ISIS remains operating normally.

GPU Voltage (if available)	CHECKED	RSP
---	----------------------	------------

Check the ELEC page on the MFD if voltage is within 28.0 V (-2.0 V+1.0 V).

Avionics Master 1 & 2	PUSHED OUT	RSP
--	-------------------------	------------



CHALLENGE **ACTION** **PERFORMED BY**
GPU (if available)..... PUSHED IN RSP

When the GPU button is selected, the "GPU AVAIL" message on it goes off and its white stripe lights up.

Fuel Pump Power Tank 2 ON RSP

To start the APU, select one of the TANK 2 electric fuel pumps and switch the PUMP PWR TANK 2 to on.

If necessary, the TANK 1 may be used via Fuel XFEED Procedure.

Navigation Light..... ON RSP

FIRE EXTINGUISHER PanelCHECKED RSP

- Press and hold (for at least 2 seconds) the FIRE DETECTION TEST button and observe the following EICAS messages, lights and warnings:
- Aural warning.
- Fire handles illuminated.
- BAGG EXTG button illuminated (for airplanes with baggage hold extinguishing only).
- Warning lights flashing.
- "APU FIRE" EICAS message.
- "ENG 1(2) FIRE" EICAS message.
- "BAGG SMOKE" EICAS message (class C compartment only).
- "APU FIREDET FAIL" EICAS message.
- "E1 (2) FIREDET FAIL" EICAS message.

NOTE: - On the ground if the FIRE DETECTION TEST button is held for more than 10 seconds with APU running, it will cause an automatic APU Shutdown.

- If it's necessary to repeat the test, wait at least 6 seconds to press the TEST button.
- If FIRE DETECTION TEST button is held for less than 2 seconds the BAGG EXTG button may remain illuminated. If this happen, repeat the test.

2-13	Page 2	Code 01
------	-----------	------------

CHALLENGE

ACTION

PERFORMED BY

APU AS REQUIREDRSP

To start the APU, turn the knob to ON, wait 3 seconds and then momentarily to START. Monitor APU EGT and RPM increasing within limits. The APU generator will come on line after RPM exceeds 95%.

NOTE: For airplanes equipped with AHRS-900 or IRS, do not star the APU before 30 seconds after airplane energization to prevent disturbances in the AHRS/IRS initialization.

Avionics Master 1 & 2..... PUSHED INRSP

Amperage may be greater than 400 A (APU GEN OVLD may appear on the EICAS) at first while the APU recharges the batteries. Do not bring any additional load on line until amperage is below 400 A. Allow a few seconds for the APU GEN OVLD message to disappear before switching the avionics master to ON.

User: aherrera - Printed By myTechCare - Aug 09/22 - 14:17:22

SOP-145/1489

REVISION 4

2-13	Page 3	Code 01
------	-----------	------------



CHALLENGE

ACTION

PERFORMED BY

.....**With APU Power**

GPU PUSHED OUT RSP

Crew must deselect the GPU as soon as the APU is running and stable to prevent the ground crew from disconnecting it while it is still powering the busses, which causes an unwanted transient.

.....**3 minutes After APU Start**.....

NOTE: Following every APU start attempt, allow 3 minutes of APU warm-up before adding pneumatic load. This is particularly important after unsuccessful APU start attempts, so as to permit that excessive fuel accumulated during the previous start attempts is burned, preventing fuel odor inside the cabin/cockpit.

APU Bleed PUSHED IN RSP

Air ConditioningAS REQUIRED RSP

NOTE: Shed buses must be set to OVRD to operate the recirculation fans or galley power when APU generator energizes the electrical system.

User: aherrera - Printed By myTechCare - Aug 09/22 - 14:17:22

2-13	Page 4	Code 01
------	-----------	------------

EXTERNAL SAFETY INSPECTION

The External Inspection procedures are normally performed by the RSP prior to each flight.

When conducting walk around, pilots must be alert that moving vehicles around the airplane and surroundings is/are not obviously unsafe for operation.

In case of suspicious object is identified, inform immediately the security staff.

Prior to starting the external inspection:

CHALLENGE	ACTION	PERFORMED BY
External Lights	AS REQUIRED	_____

Maintenance personnel should make the external lights check. If necessary flight crew should perform the external lights test, turning the lights ON, and then OFF immediately after checking them.

Emergency/Parking Brake	ON	_____
--------------------------------------	-----------------	-------

Photoluminescent Emergency Lights (if applicable)	CHARGED	_____
--	----------------------	-------

Recommended walk-around sequence:

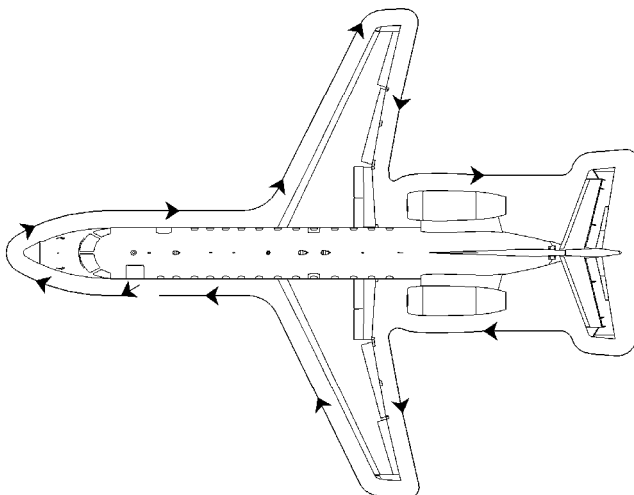

11sAOM1020039.MCE

EXTERNAL INSPECTION CHECK

<p>LEFT FWD FUSELAGE</p>	<ul style="list-style-type: none"> - Fwd Pax Door - Access Doors and Panels - Static Ports/Sensors/Pitot Tubes <p>Verify condition with no obstructions, covers or damage.</p>
<p>NOSE SECTION</p>	<ul style="list-style-type: none"> - Windshield Wipers (if applicable) - Windows - Air Inlets <p>No obstruction or damage.</p> <ul style="list-style-type: none"> - Radome - Nose Gear <p>Check if the nose wheel position indication mark is within the nose wheel position indication scale limits.</p> <ul style="list-style-type: none"> - Wheels and Tires <p>Verify condition with no obstructions, covers or damage. Verify tire pressure (if applicable).</p> <ul style="list-style-type: none"> - Nose Gear Up Lock Hook <p>Unlocked. If the uplock hook is in the LOCKED position, cycle the freefall lever to reposition the uplock to the UNLOCKED position.</p> <ul style="list-style-type: none"> - Nose Gear Struts/Wheel Well/Doors <p>Condition and no leaks.</p> <ul style="list-style-type: none"> - Ground Safety Pin <p>Removed.</p> <ul style="list-style-type: none"> - Static Discharger <p>Verify condition. Ensure the static discharger is present. Otherwise, refer to the CDL for dispatch with missing items.</p> <ul style="list-style-type: none"> - Landing and Taxi Lights <p>Clean and undamaged.</p>

(Continued)

<p>2-15</p>	<p>Page 2</p>	<p>Code 01</p>
-------------	-------------------	--------------------

EXTERNAL INSPECTION CHECK

**RIGHT FWD
FUSELAGE**

- **Hydraulic Compartment**
No Leaks. Remove Safety Pin (if applicable).
- **Oxygen Discharge Indicator**
Green Disc.
- **Static Ports/Sensors/Pitot Tubes**
Verify condition with no obstructions, covers or damage.
- **Fwd Service Door (if applicable)**
If not in use, visibly secured.
- **Access Doors and Panels**
Secured.
- **Fueling Compartment Door**
Secured.
- **Inspection Lights**
Clean and undamaged.
- **Air Inlets and Outlets**
No obstruction or damage.
- **Red Beacon**
Clean and undamaged.
- **Fuel Tanks Draining (if applicable)**
Perform.
- **Antennas**
Undamaged.
- **Ram Air Inlets**
No obstruction or damage.
- **Fluid Drain Holes**
Condition and no leaks.
- **Landing and Emergency Lights**
Clean and undamaged.

(Continued)

EXTERNAL INSPECTION CHECK

RIGHT WING

- **Wing Leading Edges**
Condition.
- **Access Doors and Panels**
Secured.
- **Direct Measuring Sticks**
Pushed IN and no leaks.
- **Air Inlets, Outlets and Vents**
No obstruction or damage.
- **Vortilons and Vortex Generators**
Number and condition.
- **Navigation and Strobe Lights**
Clean and undamaged.
- **Static Dischargers**
Number and condition. Refer to the CDL for dispatch with missing items.
- **Flight Control Surfaces and Fairings**
Surfaces clear and unobstructed.

**RIGHT MAIN
GEAR**

- **Wheels and Tires**
Condition. Verify tire pressure (if applicable).
- **Main Gear Up Lock Hook**
Unlocked. If the uplock hook is in the LOCKED position, cycle the freefall lever to reposition the uplock to the UNLOCKED position. Carry out this procedure with pins in place.
- **Gear Struts/Wheel Wells**
Condition and no leaks.
- **Ground Safety Pin**
Removed.
- **Brake Wear Indicators**
Check.

(Continued)

2-15	Page 4	Code 01
------	-----------	------------

EXTERNAL INSPECTION CHECK

RIGHT AFT FUSELAGE	<ul style="list-style-type: none"> - Air Inlets and Outlets No obstruction or damage. - Antennas Undamaged. - Pylon Undamaged. - Engines Check engine for leaks, damage, FO's in the air inlets and check access panels secured. - Thrust Reverser Doors Flush with Nacelle. - Access Doors and Panels Secured.
TAIL SECTION	<ul style="list-style-type: none"> - Horizontal Stabilizer Surfaces clear and unobstructed. - Logo Lights Clean and undamaged. - Flight Control Surfaces Surfaces clear and unobstructed. - Static Dischargers Number and condition. Refer to the CDL for dispatch with missing items. - APU Condition.

(Continued)

EXTERNAL INSPECTION CHECK

<p>LEFT AFT FUSELAGE</p>	<ul style="list-style-type: none"> - Baggage Door Latched. Lock Panel Closed. - Pressurization Static Ports No obstruction or damage. - Air Inlets and Outlets No obstruction or damage. - Antennas Undamaged. - Pylon Undamaged. - Engines Check engine for leaks, damage, FO's in the air inlets and check access panels secured. - Thrust Reverser Doors Flush with Nacelle. - Access Doors and Panels Secured.
<p>LEFT MAIN GEAR</p>	<ul style="list-style-type: none"> - Wheels and Tires Condition. Verify tire pressure (if applicable). - Main Gear Up Lock Hook Unlocked. If the uplock hook is in the LOCKED position, cycle the freefall lever to reposition the uplock to the UNLOCKED position. Carry out this procedure with pins in place. - Gear Struts/Wheel Wells Condition and no leaks. - Ground Safety Pin Removed. - Brake Wear Indicators Check.

(Continued)

<p>2-15</p>	<p>Page 6</p>	<p>Code 01</p>
-------------	-------------------	--------------------

EXTERNAL INSPECTION CHECK

<p>LEFT WING</p>	<ul style="list-style-type: none"> - Flight Control Surfaces and Fairings Surfaces clear and unobstructed. - Access Doors and Panels Secured. - Direct Measuring Sticks Pushed IN and no leaks. - Air Inlets, Outlets and Vents No obstruction or damage. - Vortilons and Vortex Generators Number and condition. - Navigation and Strobe Lights Clean and undamaged. - Static Dischargers Number and condition. Refer to the CDL for dispatch with missing items. - Wing Leading Edges Condition.
<p>LEFT FWD FUSELAGE</p>	<ul style="list-style-type: none"> - Landing and Emergency Lights Clean and undamaged. - Ram Air Inlets No obstruction or damage.

User: aherrera - Printed By myTechCare - Aug 09/22 - 14:17:22



INTENTIONALLY BLANK

User: aherrera - Printed By myTechCare - Aug 09/22 - 14:17:22

2-15	Page 8	Code 01
------	-----------	------------

Copyright © by Embraer. Refer to cover page for details.

REVISION 4

SOP-145/1489



- The sound of oxygen flowing must be heard momentarily on the speaker, thereby assuring the microphone electrical integrity.
- Set the mask to 100%. (*)
- After finishing the test, select the BOOM position on the Audio Panel.

(*) Applicable only to Puritan Bennett or B/E Aerospace masks.

CHALLENGE	ACTION / RESPONSE	PERFORMED BY
CVR	CHECKED	RSP

(Answered by LSP)

Press the CVR TEST button and check the STATUS LED illuminated for about one second.

Electrical Panel	SET	RSP
-------------------------------	------------------	------------

(Answered by LSP)

- | | |
|------------------------------------|-------------|
| GEN 1, 3, 2 and 4 Buttons..... | PUSHED IN |
| GPU Button..... | AS REQUIRED |
| APU Button | PUSHED IN |
| Batteries 1 & 2 | AUTO |
| ESSENTIAL POWER Button | PUSHED OUT |
| BUS TIES Selector | AUTO |
| SHED BUSES Selector | AS REQUIRED |
| AC PWR Button (if installed) | PUSHED IN |
| BACKUP Button..... | PUSHED IN |
| AVIONICS MASTER Button | PUSHED IN |

Emergency Lights.....	ARM	RSP
------------------------------	------------------	------------

(Answered by LSP)

Photoluminescent Emergency Lights		
(if applicable)	CHARGED	RSP

2-17	Page 2	Code 01
------	-----------	------------

Ref. Anti-Ice Policy: the following criteria must be observed when setting ref. Anti-ice to ON or to OFF:

Whenever temperature on ground is at or below 10°C and there is visible moisture in the air, it must be assumed that icing conditions are present. Under these circumstances the use of engine anti-ice (anti-ice override switch to ENG) is mandatory.

The ERJ145/135 anti-ice system is such that if any ice is detected at a speed above 25 Kt the whole ice protection system goes ON. If chances are that ice will be encountered during takeoff then REF A/ICE must be set to ON so that the FADEC allows a ITT margin for the anti-ice ON condition.

If REF A/ICE is set to ON then the takeoff performance-limited weight must be based on the anti-ice ON condition.

CHALLENGE	ACTION / RESPONSE	PERFORMED BY
-----------	-------------------	--------------

EXTERIOR LIGHTS

Panel **AS REQUIRED**.....**RSP**

Engine 2 Fire Handle**PUSHED IN**.....**RSP**

FLIGHT CONTROLS Panel.....**CHECK**.....**RSP**

AILERON SHUTOFF SYS 1 and 2 Buttons PUSHED IN

RUDDER SHUTOFF SYS 1 and 2 Buttons PUSHED IN

HYDRAULIC Panel.....**CHECK**.....**RSP**

Verify ENG PUMP SHUTOFF 1 and 2 Buttons PUSHED OUT, guarded and no striped bars illuminated.

* **ELEC PUMP SYS 1 and SYS 2**

Selectors **ON/THEN AUTO**.....**RSP**

(Answered by LSP)

Verify hydraulic pressures within 2900 ± 200 psi and hydraulic fluid level 1 & 2 on “green band”. After it, return the ELEC PUMP Selectors to OFF.

ELEC PUMP SYS 1

and SYS 2 Selectors..... **OFF**.....**RSP**

(Answered by LSP)

NOTE: If the Batteries are the only electrical source, DO NOT select HYD ELEC PUMP to AUTO or ON.

CHALLENGE

ACTION / RESPONSE

PERFORMED BY

Oxygen Masks & RegulatorsCHECK..... LSP & RSP

(Answered by LSP/RSP)

- Select ECS/A/I page on MFD.

Minimum oxygen pressure for dispatch:

CREW OXYGEN	Min Press (at 21°C)
Pilot and First Officer	1100 psi
Pilot, First Officer and Observer	1500 psi

PAX OXYGEN	Min Press (at 21°C)
Airplane equipped with one cylinder	1150 psi

Both pilots must check their respective masks:

- Select the MASK position on the Audio Panel.
- Set the mask to 100%.
- Select SPKR on the Audio Panel and set the volume to mid-range.
- Select HOT MIC on the control wheel communication switch.
- Actuate the test button on the mask stowage location. Check that the blinker changes color. (*)
- The OXY ON flag must appear on the stowage box. (*)
- For EROS masks: While maintaining the RESET TEST lever (TEST/SHUTOFF sliding control) depressed, check that the blinker changes color momentarily, and then depress the PRESS-TO-TEST regulator for 1 second.
- For Puritan Bennett or B/E Aerospace masks: Set the regulator's control knob to EMERGENCY and momentarily actuate the test button on the mask stowage location.
- Check that the blinker changes color.
- The OXY ON flag must appear on the box. (*)
- The sound of oxygen flowing must be heard momentarily on the speaker, thereby assuring the microphone electrical integrity. Set the mask to 100%. (*)
- After finishing the test, select the BOOM position on the Audio Panel.

(*) Applicable only to Puritan Bennett or B/E Aerospace masks.



CHALLENGE

ACTION / RESPONSE

PERFORMED BY

◆ **Flight Instruments.....SET/X-CKD.....LSP & RSP**

(Answered by LSP/RSP)

Verify:

- Airspeed tapes not showing speed.
- EADIs leveled and flag-free.
- Initial assigned altitude on the ALT SEL.
- Altitude tape indications cross-check.
- Both VSIs showing zero.
- EHSIs with the courses selected according to the intended departure procedure and NAV source selected.
- EHSIs and magnetic compass flag free and showing the same magnetic heading.
- Heading bug set according to the proposed departure procedure.
- Weather set on PFD and/or MFDs MAP page as required.
- It is recommended that PM sets the Terrain on MFD up to MSA.
- Set the MFDs MAP page menu as required.
- Adjust the altimeter setting.
- ISIS or Standby Instruments checked and set.

NOTE: The airplane must not be moved during the first 90 seconds after power-up, while the ISIS is undergoing alignment. Moving the airplane during this period can cause in-flight attitude indication errors, that are not noticeable on ground.

MFD SYS Pages CHECK.....LSP & RSP

Select T/O page and check ENG OIL LEVEL. Select and check the other systems pages.

◆ **RMU.....SET.....LSP & RSP**

(Answered by LSP/RSP)

- Set COMM and NAV radios.
- TCAS Test: place yellow cursor box over the code and press RMU TEST button for 5 to 7 seconds and wait for OK message on RMU and aural message "TCAS TEST, PASSED".
- To insert FLIGHT NUMBER or CALL SIGN on the RMU, select PAGE button and press ATC/TCAS line select key.

2-17	Page 10	Code 01
------	------------	------------

REVISION 8

CHALLENGE

ACTION / RESPONSE

PERFORMED BY

Flight Control DISCONNECT

Handles.....CHECK LSP

– Verify ELEV DISC and AIL DISC with no lights.

Speed Brake Lever CLOSED LSP

Thrust Levers IDLE LSP

(Answered by LSP)

◆ Stall Protection SystemCHECK LSP

(Answered by LSP)

Wait for IRS alignment (if installed).

- Release GUST LOCK and pull control column to neutral position.
- Press STALL PROTECTION TEST button and check if both stick shaker and pusher actuate and if button amber light extinguish.
- The test takes about 5 seconds and is valid only if the amber light on the TEST button extinguishes.
- Verify the STALL PROTECTION CUTOUT 1 and 2 buttons PUSHED OUT, guarded and no striped bars illuminated.

TRIM PanelCHECK LSP

(Answered by LSP)

Verify that ROLL, YAW and PITCH (Main and Backup) trims are operating properly both ways. Verify system's 3 seconds protection working properly. Adjust YAW and ROLL trims to the neutral position and PITCH trim to the green band.

BACK-UP TUNING (if installed)..... SET LSP

Set to NORMAL and copying RMU2.

COMM 3 (if installed) SET LSP

Press the transfer button in case of an error message on the radio display.



CHALLENGE

ACTION / RESPONSE

PERFORMED BY

◆ **PRESSURIZATION Panel SET LSP**

(Answered by LSP)

- Set destination airport elevation.
- DUMP and AUTO/MAN switches guarded and not illuminated.
- Manual controller knob set on FULL DOWN (green mark) position.
- If applicable, refer to High Altitude Operation Procedure on Airplane Operations Manual.

◆ **FMS SET LSP & RSP**

(Answered by LSP/RSP)

- Check NAVIGATION DATA BASE expire date.
- PF sets the route according to the flight plan and both pilots check course, distance, time and altitude on each waypoint.

RSP announces: "BEFORE START CHECK LIST COMPLETE DOWN TO THE LINE".

If VNAV is installed and is intended, on PERF INIT Page 2, it is suggested that both LSP and RSP must set cautionary the descent schedule regarding:

- the difference from cruise schedule (if VFLC is intended), and
- the descent angle (if VPATH is intended).

CAUTION: HIGH DIFFERENCES BETWEEN CRUISE AND DESCENT SPEEDS OR HIGH DESCENT ANGLES ON FMS SETTINGS MIGHT CAUSE UNCOMFORTABLE PITCH CHANGES.

To activate the VNAV (if applicable), the crew must close the flight plan with a destination and complete all performance initialization data. The ACTIVE FLIGHT PLAN page and PROGRESS page 2 displays VNAV information.

CAUTION: VNAV IS PROHIBITED ON QFE OPERATION.

User: aherrera - Printed By myTechCare - Aug 09/22 - 14:17:22

2-17	Page 12	Code 01
------	------------	------------

REVISION 10

-----SHORTLY BEFORE START UP -----

◆ **FUEL QTYCHECK LSP & RSP**

(Answered by LSP/RSP)

◆ **ELECTRONIC FLIGHT BAG SET LSP & RSP**

- Verify EFB with adequate battery level or properly connected to power source;
- Check software and software database properly updated;
- If applicable set performance and weight and balance initialization data;
- Check performance and weight and balance data;
- If applicable set navigation charts and navigation data.

◆ **FMSCOMPLETED LSP & RSP**

(Answered by LSP/RSP)

The LSP must complete data entry into the FMS including TOTAL FUEL, CARGO DATA and PAX NUMBER.

User: aherrera - Printed By myTechCare - Aug 09/22 - 14:17:22



CHALLENGE

ACTION / RESPONSE

PERFORMED BY

◆ **Speed Bugs SET RSP**

(Answered by LSP)

Set V_1 , V_R , V_2 and V_{APP} on the MFD. Set V_{FS} on the PFD.
In case of Noise Abatement procedure set V_2+10 on the PFD.

◆ **HF (if installed) SET LSP/RSP**

◆ **TRIM Panel..... SET/ZERO/ZERO LSP**

(Answered by LSP)

Set the PITCH trim according to load sheet and verify YAW and ROLL trims to the neutral position.

PITCH TRIM TAKEOFF SETTING						
CG POSITION	EMB-145	LESS THAN OR EQUAL TO 27.5%	27.6% to 32.5%	32.6% to 36.5%	36.6% to 41.5%	ABOVE OR EQUAL TO 41.6%
	EMB-135	LESS THAN OR EQUAL TO 26.5%	26.6% to 30.0%	30.1% to 33.0%	33.1% to 36.5%	ABOVE OR EQUAL TO 36.6%
PITCH TRIM UNITS		8	7	6	5	4

◆ **Doors & Windows CLOSED LSP & RSP**

(Answered by LSP/RSP)

Both pilots must verify that their respective cockpit window is closed and the RSP should select MFD T/O page to check all airplane doors closed indications.

Check the cockpit door securely closed.

Both pilots should select TCAS page on MFD for takeoff.

User: aherrera - Printed By myTechCare - Aug 09/22 - 14:17:22

CHALLENGE

ACTION / RESPONSE

PERFORMED BY

◆ **Takeoff Briefing COMPLETED LSP & RSP**

(Answered by LSP/RSP)

- The takeoff briefing should be performed by the PF and the left seat pilot must state the Reject Takeoff procedures.
- The briefing should describe the departure procedures, taxi out routes, power reductions, weather, terrain/MSA, noise abatement procedures, low visibility procedures, inoperative airplane components, runway in use/condition, return alternate airports, NOTAMs and any required operational procedures that differ from the normal procedures. It is recommended to perform the takeoff briefing before engine start.

◆ **Fuel Pump Power ON RSP**

(Answered by LSP)

◆ **Red Beacon ON RSP**

(Answered by LSP)

Ground Equipment AS REQUIRED LSP

If performing a push back assure that the ground equipment not used for this procedure is removed.

◆ **Emergency/
Parking Brake AS REQUIRED LSP**

(Answered by LSP)

Verify if the Emergency/Parking brake is set in accordance with the engine start procedures.

User: aherrera - Printed By myTechCare - Aug 09/22 - 14:17:22



CHALLENGE

ACTION / RESPONSE

PERFORMED BY

◆ **Steering..... AS REQUIRED..... LSP**

(Answered by LSP)

Push-back required: DISENGAGE pressing the trigger on the yoke and observe STEERING INOP message on EICAS.

No push-back required or after push-back: ENGAGE pressing STEERING HANDWELL and observe STEERING INOP message disappear on EICAS.

NOTE: Steering handle actuation with nose wheels beyond their operational limits may cause damage to the nose wheel steering system.

Safety Pins..... ON BOARD..... RSP

(Answered by LSP)

Check 3 Gear pins and 1 Hydraulic pin.

Locking Pins (if applicable) .. ON BOARD..... RSP

Check Emergency Exit pin.

RSP announces: "BEFORE START CHECK LIST COMPLETE".

◆ **ON THROUGH FLIGHTS CHECKLITS.**

User: aherrera - Printed By myTechCare - Aug 09/22 - 14:17:22

2-17	Page 16	Code 01
------	------------	------------

ENGINE START

Either engine 1 or engine 2 may be started first. However, the following considerations are important before the engine start:

- Starting engine 1 during towing operations: to avoid damage to the nose landing gear while towing, disengage the steering. The steering is disengaged through the steering disengage button on the control wheel. Alternatively, for airplanes Post-Mod. SB 145-32-0057 the steering may be disengaged on ground through the external steering disengagement switch. Refer to AOM sections 1-12-10 and 2-12-15 for details.
- Single engine taxi: make sure that the installed gust lock lever allows single engine taxi with the associated engine to be started.
- Logistic regarding passengers boarding and ground personal clearance, according to local authority allowances.
- For engine start using APU or LPU, refer to AOM section 1-2-81.

CHALLENGE

ACTION

Start/Stop Selector START, THEN RUN

Turn the start selector to RUN for 2 seconds, then turn the switch to the START position momentarily (signals the initiate start sequence to the FADEC) and then to RUN, and start the stopwatch.

Increase in N2 CHECKED

Verify increase in N2 RPM within 10 seconds of start selection. Make sure N2 accelerates normally.

Ignition is activated when N2 is at approximately 14% N2. Fuel is injected when N2 is at approximately 31.5% (28.5% for airplanes equipped with FADEC B7.4 and on) or 12 seconds after ignition is activated.



CHALLENGE

ACTION

IGN A (B) annunciation..... CHECKED

Observe the annunciation IGN A (B) at about 14% N2.
 With ignition in AUTO, only the FADEC in control activates the ignition system. FADEC in control is alternated on every subsequent ground start. Only one ignition channel is activated on grounds starts. Ignition channels are also alternated every subsequent start.
 If ignition is set to OFF, FADEC neither activates ignition nor actuates the fuel valve to open, thus allowing dry motoring. However, a dry motoring procedure must not be performed if one of the FADECs is declared incapable.

FF/ITT CHECKED

Observe the fuel flow and ITT indications raise at about 31.5% N2 (28.5% for airplanes equipped with FADEC B7.4 and on).
 For airplanes equipped with FADEC older than B8.0, there is no automatic shut-down by the FADEC for an overtemperature on start. FADEC B8.0 and on has an automatic shut-down as a backup protection. Independently of the FADEC version, the pilot must keep his hands on START/RUN/STOP switch and manually abort the engine start if necessary.

IGN A (B) annunciation..... CHECKED OFF

Verify the annunciation IGN A (B) go OFF at about 57% N2.
 The start cycle ends at approximately 57% N2, which can be observed when IGNITION A or B annunciation on EICAS disappears. After start is completed, engine stabilizes at about 64% N2 and 24% N1.

User: aherrera - Printed By myTechCare - Aug 09/22 - 14:17:22

2-17	Page 18	Code 01
------	------------	------------

REVISION 10

CHALLENGE

ACTION

Engine parameters CHECKED

Verify that the engine stabilizes at about 64% N2 (70% N2 for airplanes equipped with FADEC 9.4.1 and on) and 24% N1. Verify ITT, fuel flow and oil pressure for normal indications.

CAUTION: ABORT THE ENGINE START BY SELECTING THE START/STOP SELECTOR TO STOP IF AN ABNORMAL ENGINE START IS DETECTED.

NOTE: - Light-ups at 28% N2 will be achieved with systems meeting minimum performance requirements. If light-ups are occurring below 28%, the airplane should be scheduled for maintenance to avoid disruptions to passenger service.

- If light-ups are occurring later than 5 seconds after the first fuel flow indication, the airplane should be scheduled for maintenance to avoid disruptions to passenger service.
- If the light-up occurs between 5 and 10 seconds after the first fuel flow indication, smoke and a momentary flash of combustion may be produced.
- Routine operations may continue subsequent to any light-up achieved within 10 seconds after the first fuel flow indication.

Repeat the procedure for the other engine.

If any starting limit is exceeded prior to aborting a start, do not attempt further starts and report to the maintenance personnel.

If a hung or no start occurs, accomplish the Dry Motoring Procedure before attempting another start.

User: aherrera - Printed By myTechCare - Aug 09/22 - 14:17:22



ABNORMAL ENGINE START INDICATIONS

It is the Captain's responsibility to monitor engine parameters and manually abort the start in the cases described below:

- N1 and/or N2 failing to accelerate to stable idle speed (hung start).
- N1 rotation is not confirmed or decreases.
- No N2 increase within 5 seconds after start selection.
- ITT exceeds start limit (hot start).
- If oil pressure stabilizes below the engine minimum limits.
- An intermittent electrical pneumatic or starter malfunction occurs before the starter disengagement.
- Abnormal noise, vibration, fire, or smoke.

NOTE: In case an automatic abort occurs, or engine start is manually aborted due to abnormal engine indications, its cause must be investigated and corrected before further attempts to start.

The Captain must call for the ABNORMAL ENGINE START checklist.

User: aherrera - Printed By myTechCare - Aug 09/22 - 14:17:22

2-17	Page 20	Code 01
------	------------	------------

AFTER START

CHALLENGE **ACTION / RESPONSE** **PERFORMED BY**
Ground EquipmentREMOVED..... LSP

(Answered by LSP)

Captain must be sure that the emergency/parking brake is set, nose gear pins and ground equipment have been removed.

Electrical PanelSET.....RSP

(Answered by LSP)

If the SHED BUSES are set to OVRD, switch them to AUTO.

APUAS REQUIRED.....RSP

(Answered by LSP)

Set the APU ON or OFF according to the electrical and pressurization systems. The APU usage shall be defined for a specific operation in order to minimize the overall costs.

FADEC.....RESET/ALTN.....RSP

(Answered by LSP)

It is important to ensure that controlling and the standby FADEC's are properly set.

Elec Hyd Pumps.....AUTO.....RSP

(Answered by LSP)

RSP must set the ELECTRIC HYD PUMP'S knobs to AUTO after start.

Windshield HeatingAS REQUIRED.....RSP

(Answered by LSP)

Turn Windshield Heating ON if icing conditions or windshield fogging is encountered or anticipated.

For airplanes equipped with PPG windshield, the windshield heating system may be selected ON during all flight phases.

User: aherrera - Printed By myTechCare - Aug 09/22 - 14:17:22



CHALLENGE ACTION / RESPONSE PERFORMED BY
AIR COND/PNEUMATIC PanelSET RSP

(Answered by LSP)

CONDITION	ENGINE MODE	ENGINE BLEED	APU BLEED	CROSSBLEED
No icing	ALT T/O	Open	Closed	Auto
	T/O (1)	Closed	Open	Open
	E T/O	Closed	Open	Open
Icing	ALT T/O	Open	Closed	Auto
	T/O	Open	Closed	Auto
	E T/O	Open	Closed	Auto

Takeoff Data CHECKED RSP

Check the ATTCS annunciation on EICAS.

Transponder AS REQUIRED RSP

RSP selects the transponder mode in accordance with local requirements. The use of TA/RA or TA ONLY modes on ground may trigger TCAS POP UP on MFD.

FLAPS SET ____ RSP

(Answered by LSP)

Adjust FLAPS to a setting consistent with the intended takeoff configuration and performance.

Gust Lock UNLOCKED LSP

If Electromechanical Gust Lock is installed, wait 10 seconds to perform ELEVATOR check.

Elevator CHECKED LSP

CHALLENGE

ACTION / RESPONSE

PERFORMED BY

Flight Controls CHECK... LSP & RSP

(Answered by LSP)

Release the gust lock and check AILERON and ELEVATOR free travel. Once this check is complete, the gust lock should be once again applied.

Each time electromechanical gust lock lever is set to unlocked (FREE) position elevator movement must be checked. This check must be performed at least 10 seconds after positioning the gust lock lever to the unlocked (FREE) position by moving the control column from the full up stop to the full down stop and back to the full up stop position.

The LSP should check the RUDDER by pressing the steering disengage button on the control wheel and moving the pedals from full right to full left. The RSP should follow the LSP during rudder check. Flight controls should be checked for freedom of movement in a smooth and continuous manner.

Taxi Lights ON LSP

(Answered by LSP)

Steering CHECK LSP

Verify the STEER INOP message displayed on the EICAS.

Press and hold for 5 seconds the steering handwheel maintaining it in the neutral position. Verify that the STEER INOP message is removed and, after handwheel is released, the message is not displayed again.



INTENTIONALLY BLANK

User: aherrera - Printed By myTechCare - Aug 09/22 - 14:17:22

2-25	Page 4	Code 01
------	-----------	------------

Copyright © by Embraer. Refer to cover page for details.

REVISION 8

SOP-145/1489

BEFORE TAKEOFF

CHALLENGE ACTION / RESPONSE PERFORMED BY

Takeoff BriefingPERFORM LSP

(Answered by LSP)

Cabin Crew ADVISERSP

Ice Protection TestAS REQUIREDRSP

(Answered by LSP)

The ice protection test must be carried out once a day (not necessarily at the first flight of the day) when icing conditions are forecast.

The test may be carried out completely on the ground, or in 2 separate phases (first phase on the ground and second phase in flight), depending on weather conditions and crew discretion. For ice protection test information, refer to AOM Supplementary Procedures, Environmental, section 1-02-79.

XFEEDOFFRSP

PC Power System (if installed).....OFFRSP

The PC Power System must be turned off until the airplane reaches 10000 ft.

Lights ONRSP

Turn ON TAXI (if not ON yet) and STROBE lights.

Turn ON LDG 1, NOSE and LDG 2 lights when takeoff clearance is received, and turn OFF TAXI light (if not OFF yet).

It is advisable to have strobe lights ON whenever entering or crossing an active runway.

Brakes Temperature CHECKRSP

(Answered by LSP)

Verify brakes temperature in “green range” on the MFD HYD page. Takeoff cannot be attempted with brake temperatures outside the “green range”. LSP and RSP should select TCAS page on MFD.



CHALLENGE **ACTION / RESPONSE** **PERFORMED BY**
EICAS**CHECK ...LSP & RSP**

(Answered by LSP)

Check:

- No EICAS messages displayed.
- Thrust rate mode.

Transponder**TA/RA** **RSP**

(Answered by LSP)

Takeoff Configuration.....CHECK **RSP**

(Answered by LSP)

Right Seat Pilot presses the T/O CONFIG Button and "TAKEOFF OK" synthetic message shall be heard.

Flight Director**SET** **RSP**

Press GO AROUND button. Check that the FD is visible on the PFD.

Thrust Rating.....CHECKED **RSP**

Gust Lock..... UNLOCKED **RSP**

(Answered by LSP)

If Electromechanical Gust Lock is installed, wait 10 seconds to perform ELEVATOR check.

Elevator.....CHECKED **RSP**

(Answered by LSP)

NOTE: - If the ENGINE has not been running in the previous 90 minutes ("Cold" Engine) ensure at least 4 minutes to warm-up before apply takeoff power.

- If the ENGINE has been running in the previous 90 minutes ("Warm" Engine) ensure at least 2 minutes to warm-up before apply takeoff power.
- To increase N2 above 83% the engine oil temperature must be at least 40°C.

2-29	Page 2	Code 01
------	-----------	------------

User: aherrera - Printed By myTechCare - Aug 09/22 - 14:17:22

AFTER TAKEOFF

This checklist should be initiated as soon as possible after FLAPS are retracted.

NOTE: The airplane should be trimmed before 160 KIAS. Failure to accomplish the above procedure may lead to an inoperative trim condition not associated with any EICAS message.

CHALLENGE	ACTION / RESPONSE	PERFORMED BY
Landing Gear	UP	PM

(Answered by PM)

PM commands landing gear up after PF has requested and confirms the three white UP indications on the EICAS.

FLAPS	0	PM
--------------------	----------------	-----------

(Answered by PM)

PM retracts FLAPS at acceleration altitude according Normal takeoff for Flaps 9, 18 or 22° schedule.

Thrust Rating	CLB	PM
----------------------------	------------------	-----------

(Answered by PM)

- THRUST RATING panel: CLB mode.
- EICAS: check CLB indication.

Windshield Heating	AS REQUIRED	PM
---------------------------------	--------------------------	-----------

(Answered by PM)

Turn Windshield Heating ON if icing conditions or windshield fogging is encountered or anticipated.

For airplanes equipped with PPG windshield, the windshield heating system may be selected ON during all flight phases.



CHALLENGE **ACTION / RESPONSE** **PERFORMED BY**

AIR COND/PNEUMATIC PanelSET PM

(Answered by PM)

- Check for the proper air conditioning and pressurization settings and parameters.
- Takeoff with APU BLEED:
 - Engine BLEED1 and BLEED2 buttons: PUSH IN.
 - XBLEED knob: set AUTO.
 - APU BLEED button: PUSH OUT.
- Takeoff with Engine BLEED, T/O or E T/O: Both PACKS are automatically reset for airplanes S/N 625 and on.

For airplanes up to S/N 625 the packs must be reset manually.

Altimeters SET & X-CHECKED PM

(Answered by PM)

Autopilot/Flight Director AS REQUIRED PM

VNAV (if applicable)..... AS REQUIRED PM

The VNAV must be selected at or above 500 ft AGL. It will automatically engage if all required conditions are satisfied, according to VNAV mode logic (refer to AOM Section 2-18-60).

The crew can change the altitude restriction associated with a waypoint on the CDU or use altitude pre-selector to include intermediate altitude clearance.

PressurizationCHECKED PM

(Answered by PM)

Once the air conditioning system is set, verify that the pressurization is functioning properly. Verify the cabin altitude, the differential pressure and the cabin rate of climb on the EICAS.

2-33	Page 2	Code 01
------	-----------	------------

User: aherrera - Printed By myTechCare - Aug 09/22 - 14:17:22



APUAS REQUIREDPM

(Answered by PM)

Shut down the APU IMMEDIATELY after the engine bleed valves are open, that is, without any cool down period.

User: aherrera - Printed By myTechCare - Aug 09/22 - 14:17:22



INTENTIONALLY BLANK

User: aherrera - Printed By myTechCare - Aug 09/22 - 14:17:22

2-33	Page 4	Code 01
------	-----------	------------

Copyright © by Embraer. Refer to cover page for details.

REVISION 10

SOP-145/1489

CLIMB

This procedure can be initiated as soon as the after Takeoff Checklist is completed.

CHALLENGE	ACTION / RESPONSE	PERFORMED BY
-----------	-------------------	--------------

-----At Transition Altitude-----

Altimeters SET & XCHECK PF & PM

Both pilots set the altimeters to standard (as required by local regulations).

The LSP also sets the Standby altimeter.

-----Above 10000 ft AFE-----

External Lights OFF PM

Upon passing 10000 ft AFE the PM switches off the external lights according to the operating policies.

FSTN BELTS AS REQUIRED PM

NO SMKG AS REQUIRED PM

Verify in accordance with local regulations.



INTENTIONALLY BLANK

User: aherrera - Printed By myTechCare - Aug 09/22 - 14:17:22

2-34	Page 2	Code 01
------	-----------	------------

Copyright © by Embraer. Refer to cover page for details.

REVISION 4

SOP-145/1489

CHALLENGE

ACTION / RESPONSE

PERFORMED BY

-----Below 10000 ft AFE-----

External Lights ONPM

Turn ON the LDG1, NOSE and LDG2 lights upon crossing 10000 ft. During night time, turn ON the LOGO light.

PASS SIGNS PanelSETPM

(Answered by PM)

Switch the FSTN BELTS light to ON upon crossing 10000 ft, if it is not ON yet.

PC Power System (if Installed) OFFPM

CurtainsSTOWEDPM

Stow any curtain used during flight for landing.

User: aherrera - Printed By myTechCare - Aug 09/22 - 14:17:22



INTENTIONALLY BLANK

User: aherrera - Printed By myTechCare - Aug 09/22 - 14:17:22

2-35	Page 4	Code 01
------	-----------	------------

APPROACH

CHALLENGE	ACTION / RESPONSE	PERFORMED BY
XFEED	OFF	PM
PASS SIGNS Panel	SET	PM
(Answered by PM)		
AIR COND/PNEUMATIC Panel	SET	PM
Altimeters	SET & X-CHECK	PF & PM
(Answered by PF/PM)		

If flight is being conducted in ICAO airspace, set the altimeters to QNH when passing the Transition Level.

Otherwise set as required by local regulations.

NOTE: VNAV is prohibited on QFE operations.

Approach Aids	SET & X-CHECK	PF & PM
(Answered by PF/PM)		

PM verifies that the frequencies and courses that were selected and pre-selected are correct for the intended approach.

Ensure that both PFDs are displaying appropriate information.

It is recommended that PM sets the Terrain on MFD below the MSA.

Also verify that the radio altimeter alert (DH) and the FMS are properly selected for the type of approach in use.



The table below shows the flap maneuvering speeds during a visual approach or during an instrument approach:

		FLAP MANEUVERING SPEED (KIAS)			
		BELOW MSLW*		ABOVE MSLW*	
FLAPS	GEAR	NO ICING CONDITIONS	WITH ICING CONDITIONS	NO ICING CONDITIONS	WITH ICING CONDITIONS
0°	Up	180	200	180	200
9°	Up/Dn	160			
18°/22°	Up/Dn	140	150		
45°	Dn	140			

*Maximum Structural Landing Weight as specified on Limitations Section.

User: aherrera - Printed By myTechCare - Aug 09/22 - 14:17:22



INTENTIONALLY BLANK

User: aherrera - Printed By myTechCare - Aug 09/22 - 14:17:22

2-41	Page 2	Code 01
------	-----------	------------

Copyright © by Embraer. Refer to cover page for details.

REVISION 8

SOP-145/1489

MISSED APPROACH

CHALLENGE ACTION / RESPONSE PERFORMED BY

Go Around ButtonPRESS..... PF

Press the Go Around buttons at the thrust levers and check if Flight Director goes to pitch 10° nose up. Rotate or verify that autopilot rotates the airplane following the Flight Director.

Thrust LeversMAX..... PF

Advance the thrust levers to MAX position and verify the engines parameter.

FLAPSSET 9°PM

With positive rate of climb:

Landing Gear.....UP.....PM

Minimum Airspeed.....V_{AC}.....PM

Maintain the pitch as commanded by the Flight Director or pitch 10° if Go Around is being performed on raw data to maintain the airplane airspeed above the minimum airspeed (approach climb speed selected on the MFD).

- NOTE:** - For coupled Go-Around the altitude loss may be 75 ft
- During Go-Around procedure, the DON'T SINK aural warning may sound. In this case monitor the sink rate and follow the Go-Around guidance.

User: aherrera - Printed By myTechCare - Aug 09/22 - 14:17:22



INTENTIONALLY BLANK

User: aherrera - Printed By myTechCare - Aug 09/22 - 14:17:22

2-42	Page 2	Code 01
------	-----------	------------

Copyright © by Embraer. Refer to cover page for details.

REVISION 4

SOP-145/1489

NOTE: In case an overcurrent protection is actuated, and the EICAS message DC BUS 2 OFF (PFD 2 and MFD 1 blank and MFD 2 displaying a red X) is displayed after a commanded engine 2 shutdown during taxi, the following actions must be carried out:

- Stop the airplane.
- Restart the engine 2.
- Taxi the airplane normally to the appropriate area.
- To shut the airplane down and reset the overcurrent protection, refer to Shutdown Procedures.

CAUTION: DURING TAXI, THE ENGINE 2 MUST NOT BE SHUTDOWN JUST BEFORE OR DURING A TURN AS THIS MAY CAUSE STEERING COMMAND LOSS (STEERING IS SUPPLIED BY DC BUS 2).

2-45	Page 2	Code 01
------	-----------	------------



CHALLENGE ACTION / RESPONSE PERFORMED BY

START/STOP SelectorsSTOPLSP

(Answered by LSP)

Once the Emergency/Parking Brake is applied, shut down the engines by selecting the engine start snobs to STOP.

NOTE: - Associated engine BLEED must be CLOSED before selecting the engine START/STOP Selectors STOP;

- The engines will not shut down with START/STOP Selectors unless Thrust Levers are first moved to IDLE;
- If STOP is selected before Thrust Lever is retarded to IDLE, momentarily cycle START/STOP Selector to RUN and back to STOP;
- The engine must run for at least 1 minute at IDLE thrust before shutdown to permit engine thermal stabilization. Time operation at or near idle, such as taxiing, is included in this 1-minute period;
- To prevent spurious overcurrents in the electrical system, engines must not be shut down concurrently with the starting of the APU. A minimum one-minute interval between those two procedures is recommended.

NOTE: If the overcurrent protection is actuated, the airplane will enter in electrical emergency when both engines are shut down (both PFDs and MFDs deenergized, but EICAS display energized). In this case, the following steps must be accomplished:

- Batteries 1 and 2..... OFF
- Bus Ties..... OFF
- Properly trained personnel must reset the electrical system through ELEC SW switch on the Maintenance Panel behind the pilot's seat.
- If the failure persists, the related fault isolation task (FIM TASK 24-60-00-810-820-A) should be accomplished.

2-49	Page 2	Code 01
------	-----------	------------

CHALLENGE **ACTION / RESPONSE** **PERFORMED BY**

Red Beacon **OFF** **LSP**

(Answered by LSP)

FSTN BELTS **OFF** **LSP**

(Answered by LSP)

LSP should turn FASTEN BELTS switch to OFF after complete engine stop.

Fuel Pump Power **AS REQUIRED** **RSP**

(Answered by LSP)

If the APU is running, keep the right fuel pump ON.

If the APU is not running, turn both fuel pumps OFF.

Elec Hyd Pumps..... **OFF** **RSP**

(Answered by LSP)

RSP switches HYDRAULIC ELEC PUMP knob to OFF.

Ice Protection System **OFF** **RSP**

(Answered by LSP)

AIR COND/PNEUMATIC Panel **SET** **RSP**

(Answered by LSP)

RSP pushes out BLEED 1 and 2 Buttons on AIR CONDITIONING Panel. If air conditioning is required, RSP pushes in APU Bleed Button (if APU is in use) and selects one PACK as required.

User: aherrera - Printed By myTechCare - Aug 09/22 - 14:17:22



INTENTIONALLY BLANK

User: aherrera - Printed By myTechCare - Aug 09/22 - 14:17:22

2-49	Page 4	Code 01
------	-----------	------------

Copyright © by Embraer. Refer to cover page for details.

REVISION 8

SOP-145/1489

LEAVING THE AIRPLANE

This procedure applies when a power down is required.

CHALLENGE	ACTION / RESPONSE	PERFORMED BY
------------------	--------------------------	---------------------

IRS (if applicable).....OFFLSP/RSP
(Answered by LSP)

Avionics Master 1 & 2..... PUSHED OUTRSP
(Answered by LSP)

RSP pushes out AVIONICS MASTER 1 & 2 buttons prior to switching GPU or APU OFF.

Emergency Lights.....OFFRSP
(Answered by LSP)

RSP switches EMERG LT from ARM to OFF before the batteries are switched OFF. Otherwise the emergency lights will illuminate and drain their batteries.

External & Internal LightsOFFRSP
(Answered by LSP)

Make sure that all internal and external lights are switched OFF (with the exception of the cockpit dome light at night) before switching OFF GPU or APU.

Passenger Signs PanelOFFRSP
(Answered by LSP)

Set EMERG LT, STERILE, NO SMKG (NO ELEC DEVICES in some configurations) and FSTN BELTS to OFF.

Weather RadarOFFLSP/RSP
(Answered by LSP/RSP)

LSP and RSP switch the radar from SBY to OFF.

RADAR.....OFFRSP
Switch the radar from STBY to OFF.



CHALLENGE **ACTION / RESPONSE** **PERFORMED BY**

Standby Attitude (if applicable)CAGED RSP

(Answered by LSP)

Cage the standby horizon. Make sure it is caged by checking whether its red flag is visible.

GPU/APU OFF RSP

(Answered by LSP)

Shut APU down by pressing the STOP button on its panel. Verify the shutdown on the EICAS. Wait until APU rotation drops to 5% before switching APU MASTER OFF.

NOTE: Do not close the air conditioning packs before shutting down the APU. Shutting down the APU while bleed air is coming out of it helps extending APU life.

If a GPU is the source of electrical power, switch it OFF through the GPU button on the Electrical System panel.

Never leave the airplane unattended and energized. A member of the maintenance team, familiar with the airplane, should always be left in charge before they leave.

AIR COND/PNEUMATIC PanelSET RSP

(Answered by LSP)

RSP sets the PACK and BLEED buttons on the Air Conditioning/Pneumatic panel to CLOSED, if they are not in this position already. The XBLEED valve should be left in AUTO. The RECIRC and GASPER buttons should be left pressed (this is their normal state).

Fuel Pumps..... OFF RSP

(Answered by LSP)

Fuel pumps are needed only as long as the APU is in use. Once the APU is shut down the fuel pumps are not needed any more. So if the airplane is being powered by the GPU or solely by the batteries the pumps are not needed.

Main and Backup Batteries OFF RSP

(Answered by LSP)

2-53	Page 2	Code 01
------	-----------	------------

REVISION 8

ENGINE START ASSISTED BY THE OPPOSITE ENGINE (CROSS START)

This procedure may be used to start the second engine using the operating engine bleed as the pneumatic source.

CHALLENGE	ACTION / RESPONSE	PERFORMED BY
APU Bleed	CLOSE	RSP
Crossbleed	AUTO or OPEN	RSP
Engine Bleed (non-operating engine)	CLOSE	RSP
Engine Bleed (operating engine)	OPEN	RSP
N2 of the operating engine must be accelerated to above 80%.		
Start/Stop Selector	START, THEN RUN	

Turn the start selector to RUN for 2 seconds, then turn the switch to the START position momentarily (signals the initiate start sequence to the FADEC) and then to RUN, and start the stopwatch.

Engine Indication..... **MONITOR**

NOTE: After the start is completed, reduce operating engine power to idle.

User: aherrera - Printed By myTechCare - Aug 09/22 - 14:17:22

ENGINE START ASSISTED BY THE APU

This procedure may be used to start the engine using the APU bleed as the pneumatic source.

NOTE: Before starting engine 2 using APU bleed while engine 1 is running, push out the BLEED 1 pushbutton.

CHALLENGE	ACTION / RESPONSE	PERFORMED BY
APU Bleed	OPEN	RSP
Crossbleed	OPEN or AUTO	RSP
Engine Bleeds	CLOSED	RSP
Start/Stop Selector	START, THEN RUN	

Turn the start selector to RUN for 2 seconds, then turn the switch to the START position momentarily (signals the initiate start sequence to the FADEC) and then to RUN, and start the stopwatch.

Engine Indication**MONITOR**

NOTE: With the APU Bleed Valve open and the Crossbleed Valve in AUTO position, the Engine 1 will always be started assisted by the APU, even when the Engine 2 is running with associated Engine Bleed Valve open.

ENGINE START WITH AIRPLANE BATTERIES AND LOW PRESSURE UNIT (LPU)

This procedure may be used when operating without APU or GPU but with the batteries and a Low Pressure Unit (LPU) available for engine start.

- NOTE:** - Before attempting to start the engines using the batteries ensure that minimum batteries voltage is 24.0 VDC.
- Accomplish a BEFORE START - FIRST FLIGHT procedure as soon as the electrical source is established.
 - The Captain may elect to start the remaining engine using the LPU or to perform a crossbleed start.
 - The engines pneumatic start does not affect the electrical system or the individual loads connected to it. The voltage of the buses fed by the batteries remain steady during engine starts, with no power transients. After the first engine start and with generators on line, the normal electrical system voltage will be between 24 V and 28.5 V.
 - It is recommended that audio communication with the ground crew be used instead of signaling.

BEFORE START

CHALLENGE	ACTION / RESPONSE	PERFORMED BY
Internal and External Safety Inspections	ACCOMPLISH	LSP/RSP
Parking Brake.....	ON	LSP
Batteries 1 & 2.....	AUTO	RSP
Avionics Masters	PUSHED IN	RSP
Emergency Lights.....	ARM	RSP
Fire Detection System.....	CHECK	RSP

REVISION 4

2-65	Page 1	Code 01
------	-----------	------------



CHALLENGE	ACTION / RESPONSE	PERFORMED BY
Crossbleed	AUTO or OPEN	RSP
Packs	OFF	RSP
Engine Bleeds	CLOSE	RSP

CLEARED TO START

Doors and Windows	CLOSED	LSP/RSP
Red Beacon	ON	RSP
Fuel Pump (associated engine).....	ON	RSP
Start Pressure	AVAILABLE	RSP

START

**Start/Stop Selector (associated engine)..... START, THEN
RUN**

Turn the start selector to RUN for 2 seconds, then turn the switch to the START position momentarily (signals the initiate start sequence to the FADEC) and then to RUN, and start the stopwatch.

Engine IndicationMONITOR

2-65	Page 2	Code 01
------	-----------	------------

SINGLE ENGINE TAXI

The procedures below are provided to allow operators to perform a single engine taxi. This procedure can be adopted at crowded airports, where the taxi time may be too long, leading to unnecessary fuel waste and air pollution.

For single engine taxi, change or complement the normal procedures according to the following.

BEFORE START

Evaluate which engine will be started based on fuel distribution on tanks, passenger boarding and baggage loading. If the airplane is operating under MEL with one engine driven generator inoperative, choose the engine which has both generators operating.

NOTE: Batteries charge may be preserved by using all available generators.

AFTER START

CHALLENGE	ACTION	PERFORMED BY
-----------	--------	--------------

FADEC Control Knob..... RESET, THEN ALTNRSP

Electric Hydraulic Pumps.....ONRSP

Check on MFD Hydraulic Page that both hydraulic systems pressure are within green range.

Air Cond/Pneumatic Panel AS REQUIREDRSP

If both air conditioning packs are required, select Crossbleed to OPEN.

Shed BusesOVRDRSP

Check all DC Buses energized and operating generators load. If required, turn off equipment not essential (galley, coffee maker, etc.). In such case, inform flight attendant that those equipment shall be off until second engine start.



TAXI

Monitor both fuel quantities to avoid excessive fuel imbalance.

BEFORE TAKEOFF

CHALLENGE	ACTION	PERFORMED BY
Non Operating Engine	START	LSP
Crossfeed.....	OFF	RSP
Shed Buses.....	AUTO	RSP
Electric Hydraulic Pumps.....	AUTO	RSP
Air Cond/Pneumatic Panel	AS REQUIRED	RSP

AFTER LANDING

CHALLENGE	ACTION	PERFORMED BY
Shed Buses.....	OVRD	RSP
Electric Hydraulic Pumps.....	AUTO	RSP
Air Cond/Pneumatic Panel	AS REQUIRED	RSP
Selected Engine	SHUTDOWN	LSP

ABNORMAL PROCEDURES

If the operating engine fails, stop the airplane as soon as possible, apply Parking Brakes and turn off both hydraulic pumps and any unnecessary equipment. APU may be used to start remaining engine and return to gate.

NOTE: Batteries will be discharging until APU or remaining generators are turned on.

2-70	Page 2	Code 01
------	-----------	------------

User: aherrera - Printed By myTechCare - Aug 09/22 - 14:17:22

HOT WEATHER

The following procedures will improve cockpit and cabin cooling during ground operations.

When engine is shutdown, apply cool air from the air conditioning cart whenever possible.

CHALLENGE	ACTION	PERFORMED BY
AIR COND RECIRC Button	PUSHED IN	RSP

CKPT/PAX CABIN

Temperature Controllers	AUTO FULL COLD	RSP
--------------------------------------	-----------------------------	------------

At every 30 minutes during continuous ground operations and also prior to takeoff the airplane, set both controllers to AUTO FULL HOT for approximately 1 minute and then back to AUTO FULL COLD.

Doors and Windows	KEEP CLOSED ...	LSP & RSP
--------------------------------	------------------------	----------------------

Passenger Cabin Gasper and Cockpit Outlets	OPEN	N/A
---	-------------------	------------

Window Shades on the Sun-exposed Side of the Cabin	CLOSED	N/A
---	---------------------	------------



INTENTIONALLY BLANK

User: aherrera - Printed By myTechCare - Aug 09/22 - 14:17:22

2-71	Page 2	Code 01
------	-----------	------------

ICE CONDITIONS, COLD WEATHER AND COLD SOAK

EXTERNAL SAFETY INSPECTION

CHALLENGE ACTION PERFORMED BY

Wheel Chocks CHECK IN PLACERSP

All Protective Covers.....CHECK REMOVEDRSP

Remove covers from engine air inlet/outlet, APU air outlet, pitot tubes, TAT probes and wheels.

Fuselage, Wing, Tail and Control

Surfaces FREE OF FROST, ICE OR SNOWRSP

Check that the fuselage, wing upper and lower surfaces, tail and control surfaces are free of frost, ice or snow. Inspect control surfaces, gaps and hinges for signs of residual fluid or gel.

A thin layer of hoarfrost is permitted on the fuselage provided the layer is thin enough to distinguish surface features underneath, such as painting and markings. Frost is not permitted on the lower/upper surface of the horizontal stabilizer or the upper surface of the wing.

Pitot Tubes/TAT/Static Ports

and AOA Vanes..... CHECKRSP

Check clear of ice and residual deicing and anti-icing fluids.

Engine/APU Air Inlet CLEAR OF ICE OR SNOWRSP

Check that the engine inlet and the APU air inlet is clear of ice or snow. Fluid applied close to the APU inlet area may be ingested and cause a flameout and result in APU internal parts damage. Preferably, all soft snow should be mechanically removed by blowing cold air across the airplane surface, using brooms or soft hand scrapers.

Landing Gear..... CLEAR OF ICE, UNOBSTRUCTEDRSP

Check that doors, gear locks and mechanisms are unobstructed and clear of ice and snow. Check that no leakage exists.



CHALLENGE ACTION PERFORMED BY

Air Conditioning Inlets/Outlets CLEAR OF ICE RSP

Fuel Tank Vents.....CLEAR OF ICE OR SNOW RSP

Batteries.....CHECK INSTALLED RSP

Certain temperatures require batteries removal to prevent cold soaking. Verify that batteries have been re-installed.

INTERNAL SAFETY INSPECTION

CHALLENGE ACTION PERFORMED BY

Batteries.....CHECK RSP

If battery voltage is below 24 V and battery temperature is colder than -15°C (5°F), replace the battery, as it may not recharge under very low temperatures.

APU.....START RSP

Observe fuel and oil limitations before APU starting. Minimum fuel temperature is -40°C (-40°F). Minimum MIL-L-23699 oil temperature is -43°C (-45°F). Minimum MIL-L-7808 oil temperature is -54°C (-65°F).

Minimum battery temperature to start the APU is -20°C (-4°F). Minimum temperature to start APU using external electrical power is -54°C (-65°F).

If APU cannot be started, apply heat from a ground cart directly into the APU compartment. Do not allow the hot air from the ground heating cart to exceed 93°C (200°F), as it may damage the components inside the compartment.

Observe RPM and EGT during starting. If the APU flames out, make sure that ice or snow deposits are cleared before attempting a second start.

After the APU has been started, RPM and EGT fluctuation may be an indication of fluid ingestion into the APU. Record any discrepancy in the logbook.

2-75	Page 2	Code 01
------	-----------	------------

User: aherrera - Printed By myTechCare - Aug 09/22 - 14:17:22

CHALLENGE ACTION PERFORMED BY

Air Conditioning.....SET.....RSP

Turn both air conditioning packs on, bleeding air from the APU (or from a ground conditioned air cart, with packs off) to warm up the interior of the airplane. The warm-up should be accomplished with all doors closed, if possible.

Turn recirculation fans on.

In very cold days, Embraer recommends a gradual warming of the cabin, as follows:

- Set air conditioning control to manual mode;
- Put the cockpit temperature selection knob in the 9 o'clock position;
- Wait approximately 3 minutes;
- Change control to automatic mode;
- Wait another 2 minutes before controlling temperature as required.

CAUTION: • MAINTAIN CABIN AT THE FIELD ELEVATION. DO NOT PRESSURIZE DE AIRPLANE.

- WITH PACKS OPERATING AND DOORS CLOSED, DO NOT LEAVE THE AIRPLANE UNATTENDED.

Main Panel.....CHECK.....RSP

Check proper operation of all instruments and systems. Liquid Cristal Display may not be readable at temperature below -20°C.

Electric Hydraulic Pumps.....ON.....RSP

Check hydraulic pressure. If pressure does not rise to normal values, warm up the hydraulic reservoir compartment with hot air and keep the electric hydraulic pumps running for 15 minutes.

Do not allow the hot air from the ground cart to exceed 93°C (200°F), as it may damage the components inside the compartment.

User: aherrera - Printed By myTechCare - Aug 09/22 - 14:17:22



CHALLENGE ACTION PERFORMED BY
Flight Controls..... ON LSP

Check control wheel, control column and rudder pedals for freedom of movement and full travel. Control forces can be increased at low temperatures.

Operate all trim systems, including back up pitch trim system, checking for freedom of movement and full travel. If any flight control is suspected of restricted movement or jamming, report to maintenance personnel.

FLAPS.....CHECK RSP

Extend and retract the flaps. Make sure the flaps are free from snow or ice before moving them. Leave flaps UP if application of anti-icing/deicing fluids is expected.

ENGINE START

SPS/ICE SPEEDS message will remain displayed after icing encounter. Before next takeoff the message must be removed by testing the Stall Protection System.

Do not start the engine until it has been checked that all ice deposits have been removed from the air inlet.

Fuel and oil temperature limits are the same as those prescribed for APU start.

Proceed with normal engine start.

In cold weather conditions, the usage of dual ignition (ignition switch rotated to the ON position) is highly recommended for the first engine start of the day or if the engine has not been run in the previous 90 minutes. This procedure may reduce the time from fuel introduction to light-up.

As a reference, this procedure can be used for temperatures below 5°C, or at operator's discretion.

After a successful start the Ignition Switch must be switched to the AUTO position.

If the engine does not start, ground heating may be necessary to warm the nacelle, Air Turbine Starter (ATS) and Starting Control Valve (SCV).

Do not allow the hot air from the ground cart to exceed 93°C (200°F), as it may damage the components inside the nacelle.

2-75	Page 4	Code 01
------	-----------	------------

User: aherrera - Printed By myTechCare - Aug 09/22 - 14:17:22

AFTER START

CHALLENGE	ACTION	PERFORMED BY
Ice Detection Override Knob	ENG	RSP

The Ice Detection Override Knob must be at ENG during all ground operations (in icing conditions) except during ice protection system test. Wing and stabilizer anti-icing must be kept off.

Crossbleed	AUTO	RSP
-------------------------	-------------------	------------

CAUTION: • BOTH ENGINE BLEEDS MUST BE OPEN, IN ORDER TO ASSURE BLEED AIR FLOW THROUGH THE LEADING EDGES. APU BLEED MUST NOT BE USED.

- DELAYING THE USE OF THE ENGINE ANTI-ICING SYSTEM UNTIL ICE BUILD-UP IS VISIBLE FROM THE COCKPIT MAY RESULT IN ICE INGESTION AND POSSIBLE ENGINE DAMAGE OR FLAME-OUT.

NOTE: - When thrust is set to below 83% N2, the ENG 1-2 A/ICE FAIL message may appear due to the low pressure available for anti-icing. Moving thrust levers forward will cause the message to disappear.

- On airplanes Pre-Mod. SB 145-30-0028, when Ice Detector Override Knob is at ENG on the ground, TAT heating is on. TAT and SAT reading may increase and cause an invalid indication (amber dashes) to appear. If TAT invalid indication causes the AHRS reversion to Basic Mode, continue the mission. The TAT invalid indication and AHRS reversion will remain until the airplane attains sufficient speed to bring the TAT sensors within the normal range of operation.
- AHRS BASIC MODE is inhibited on the ground for airplanes modified to EICAS version 16.5.
- On airplanes Post-Mod. SB 145-30-0028 or S/N 145.180 and on, TAT heating is on when Thrust Levers are set above 65° position or when the airplane is airborne.



CHALLENGE ACTION PERFORMED BY
Engine Instruments..... MONITORLSP

Continue to monitor engine instruments, mainly oil pressure and temperature. Apply associated abnormal procedure if any failure arises.

Main PanelCHECKLSP

Check proper operation of all instruments and systems.

AIRPLANE ANTI-ICING/DEICING FLUID APPLICATION WITH ENGINES/APU RUNNING.

WARNING: APU OPERATION IS NOT RECOMMENDED DURING THE AIRPLANE DEICING/ANTI-ICING PROCEDURE. IF THE APU IS KEPT IN OPERATION DURING THE DEICING/ANTI-ICING PROCEDURE, DAMAGE CAN OCCUR TO IT. IF APU OPERATION IS ABSOLUTELY NECESSARY, MAKE SURE THAT THE APU BLEED AIR VALVE IS CLOSED, PACKS ARE SET TO OFF, AND THE DEICING/ANTI-ICING FLUID IS NOT APPLIED DIRECTLY TO OR NEAR THE APU AIR INLET.

CHALLENGE ACTION PERFORMED BY
Parking Brake ONLSP

Thrust Levers IDLELSP

Gust Lock..... ENGAGELSP

Doors.....CHECK CLOSED ...LSP & RSP

FLAPS..... CHECK 0° RSP

2-75	Page 6	Code 01
------	-----------	------------

CHALLENGE ACTION PERFORMED BY

Pitch Trim AS REQUIRED LSP

To avoid APU fluid ingestion, it is recommended that pitch trim should be set from 0° to FULL NOSE DOWN, hence fluid cascades downwards and aft, keeping the stabilizer leading edge free from the fluid drip that could be ingested by the APU.

However, operators are reminded to frequently inspect surfaces for residue, as prescribed in the SNL 145-30-0006. This is applicable mainly to fluid Types II, III and IV which may leave residue on the aerodynamic quiet areas.

Engine Bleed CLOSED RSP

APU Bleed CLOSED RSP

Air Conditioning Packs OFF RSP

Packs should be off to avoid contamination of cabin air with fumes generated from ingestion of fluids in engine/APU.

Ice Detection Override Knob ENG RSP

After Deicing/Anti-icing Procedure is complete:

..... **WAIT AT LEAST 1 MINUTE**

Engine Bleeds OPEN RSP

..... **WAIT AT LEAST 3 MINUTES**

Packs OPEN RSP

APU Bleed CLOSED RSP

APU Bleed remain closed during Takeoff and initial Climb.

Wait at least one minute to open engine bleed, and three minutes to turn air conditioning packs on, thereby avoiding contaminating the airframe air conditioning system with deicing/anti-icing fluid gases.

The deicing/anti-icing fluid shall drop out after initial climb then allowing the APU bleed valve opening.



CHALLENGE ACTION PERFORMED BY

Ice Detection Override Knob.....ENG RSP

The Ice Detection Override Knob must be at ENG during all ground operations in icing conditions.

Pitch Trim.....SETLSP

Pitch Trim must be set as per CG position stated in the Weight and Balance sheet.

TAXI

The maximum recommended wind speeds for airplane towing, pivoting, turning and taxi are:

- Dry Runways..... 50 kt
- Wet Runways..... 45 kt
- Snow Covered Runways..... 30 kt
- Ice Covered Runways..... 10 kt

Power backs are not allowed. Use minimum thrust to avoid blowing snow or slush on personnel or airplanes nearby.

During taxi, "cold set" (the condition where the tire retains the flat shape it had while parked) may induce vibration in the airplane. Vibration should disappear as the tires recover their elasticity during taxi. Do not initiate your takeoff run before the cold set disappears.

Maintain a greater than normal distance behind other airplanes while taxiing in snow-covered runways, to avoid contamination by snow blown by jet blasts.

Do not apply reverse thrust during taxi, unless it is strictly necessary.

CHALLENGE ACTION PERFORMED BY

FLAPSAS REQUIRED RSP

When taxiing through slush or standing water, flaps should be retracted to avoid snow and slush contamination from the main gear wheels.

2-75	Page 8	Code 01
------	-----------	------------

User: aherrera - Printed By myTechCare - Aug 09/22 - 14:17:22

CAUTION: • IF FLAPS WERE LEFT UP DURING TAXI, COMPLETE AFTER START CHECKLIST BEFORE TAKING OFF.

- TAXI AT REDUCED SPEED IN ICE COVERED RUNWAYS TO AVOID SKIDDING THE AIRPLANE. REDUCE SPEED FOR ALL TURNS AND USE CAUTION WHEN TAXING WITH HIGH CROSSWINDS.

BEFORE TAKEOFF

Ice Protection Test:

NOTE: - The ice protection test must be carried out once a day (not necessarily at the first flight of the day) when icing conditions are forecast.

- The test may be carried out completely on the ground, or in 2 separate phases (first phase on the ground and second phase in flight), depending on weather conditions and crew discretion. For takeoffs when icing conditions exist or are anticipated for takeoff or climb, the tests in paragraph A must be performed.

On ground, if engine vibration increases, advance thrust levers, one at a time, to obtain at least 60% N1 for 5 seconds and then return to the former setting.

A - When actual icing conditions exist or are anticipated for takeoff and climb, proceed:

CHALLENGE	ACTION	PERFORMED BY
Ice Detection Override Knob	ALL	RSP
Thrust Levers	83% N2	LSP
Anti-Ice Buttons (engine wing and stabilizer)	PRESSED	RSP
Ice Detection Test Knob	1 THEN 2	RSP

Test knob must be held at least 10 seconds in each test position but no more than 15 seconds.

User: aherrera - Printed By myTechCare - Aug 09/22 - 14:17:22



CHALLENGE	ACTION	PERFORMED BY
-----------	--------	--------------

For each side separately, check that OPEN inscriptions in the buttons are illuminated and that, ICE DET 1 (or 2) FAIL and BLD 1 (or 2) LOW TEMP caution messages and ICE CONDITION advisory message are displayed on EICAS. The CROSS BLD OPEN advisory message may also be displayed.

NOTE: - Wait for the messages go out of view after each release of the Test knob.

- For the EMB-145 XR model, when the Ice Detection Test Knob is selected to 1, the CLR ICE 1, CLR ICE 2, CLR/I INOP 1 and CLR/I INOP 2 caution messages are displayed on the EICAS and the lights CLR ICE 1 and CLR ICE 2 illuminate; when the Ice Detection Test Knob is selected to 2, none of those caution messages are displayed on the EICAS.

Thrust Levers IDLE LSP

Ice Detection Override Knob..... ENG RSP

CAUTION: ICE DETECTION OVERRIDE KNOB MUST NOT BE SET TO "ALL" ON GROUND, EXCEPT DURING TEST.

B - For flight when no actual icing conditions exist or are anticipated for takeoff and climb, proceed:

Before engines start, perform the on ground test:

CHALLENGE	ACTION	PERFORMED BY
-----------	--------	--------------

Air Conditioning Packs..... OPEN RSP

APU Bleed CLOSE RSP

Engine Bleed CLOSE LSP/RSP

Anti-Ice Buttons (engine wing and stabilizer) PRESSED RSP

Ice Detection Override Knob..... AUTO RSP

2-75	Page 10	Code 01
------	------------	------------

REVISION 4

CHALLENGE ACTION PERFORMED BY

Ice Detection Test Knob..... 1 THEN 2RSP

Test knob must be held at least 10 seconds in each test position but no more than 15 seconds.

For each side separately, check that ICE DET 1 (or 2) FAIL and BLD 1 (or 2) LOW TEMP caution messages and ICE CONDITION advisory message are displayed on EICAS. The CROSS BLD OPEN advisory message and/or the PACK 1 (2) VLV FAIL caution message may also be displayed.

NOTE: For the EMB-145 XR model, when the Ice Detection Test Knob is selected to 1, the CLR ICE 1, CLR ICE 2, CLR/I INOP 1 and CLR/I INOP 2 caution messages are displayed on the EICAS and the lights CLR ICE 1 and CLR ICE 2 illuminate; when the Ice Detection Test Knob is selected to 2, none of those caution messages are displayed on the EICAS.

During climb, perform the inflight test:

Engine BleedsOPENPM

Thrust Levers THRUST SET PF

Altitude.....2000 ft to FL230 PF

TATLESS THAN 10°C N/A

Ice Detection Override Knob ALLPM

Check that OPEN inscriptions in the buttons are illuminated and NO ICE-A/ICE ON caution message is displayed on EICAS. The CROSS BLD OPEN advisory message may also be displayed.

.....**WAIT 20 SECONDS**

Ice Detection Override KnobAUTOPM

User: aherrera - Printed By myTechCare - Aug 09/22 - 14:17:22

**STANDARD
OPERATING
PROCEDURES**



CHALLENGE

ACTION

PERFORMED BY

NOTE: - The ice protection test must be fully accomplished before entering icing conditions and before reaching 23000 ft.

- In case of first attempt of Ice Protection Test method B is unsuccessful, it is allowed to perform a second attempt of Ice Protection Test by method A.

NOTE: Do not reset/alternate a FADEC after the Anti-Ice System test.

After completion of the test, set the Ice Detection Override Knob to ENG. Check that engine REF A/ICE on MFD takeoff page is set to ON.

Ignition ONLSP

Turn ignition on when standing water, ice, or snow is present on the takeoff runway.

Takeoff Briefing.....COMPLET ...LSP & RSP

Confirm $V_1/V_R/V_2$ and V_{FS} speeds for the associated runway or takeoff condition.

Flight Controls.....CHECK ...LSP & RSP

The flight controls must be checked close to the holding point if a prolonged taxi in cold soak conditions occurs or in any weather that may possibly cause flight control problems due to freezing or due to accumulation of snow or slush.

Release the gust lock and check AILERON and ELEVATOR free travel. Once this check is complete, the gust lock should be once again applied.

Each time electromechanical gust lock lever is set to unlocked (FREE) position, elevator movement must be checked. This check must be performed at least 10 seconds after positioning the gust lock lever to the unlocked (FREE) position by moving the control column from the full up stop to the full down stop and back to the full up stop position.

With the airplane taxiing on a straight line or standing still, check the RUDDER by pressing the steering disengage button on the control wheel and moving the pedals from full right to full left, and pressing the steering handle to reconnect the steering.

2-75	Page 12	Code 01
------	------------	------------

REVISION 5

User: aherrera - Printed By myTechCare - Aug 09/22 - 14:17:22

FLAPS SET RSP

Set flaps to Takeoff Setting if flaps were left up after starting.

Takeoff Configuration CHECK RSP

Ice Accumulation CHECK... LSP & RSP

Continuously monitor ice accumulation, by checking windshield and windshield wiper. High winds and jet blast may cause anti-icing fluid to flow off and many other factors contribute to reduce fluid effectiveness.

TAKEOFF

Takeoff in a normal manner. Check thrust rating mode. T/O-1 mode gives the maximum weight and thrust for the associated runway.

Do not apply static takeoff technique on an icy or slippery runway, as the airplane may begin to slide when thrust lever is advanced with brakes applied. In this case, release brakes and advance thrust levers simultaneously.

However, appropriate assessment of the takeoff distance is required as performance data available in the AFM for slippery runways is predicted on the use of static takeoff technique only. For rolling takeoffs, performance data is valid from the point where takeoff thrust is achieved.

Check N1 indication consistent with takeoff thrust setting tables (check AFM performance tables which have dedicated thrust setting tables for takeoff in icing conditions). Check N1 pointer reaching N1 target.

Apply light forward pressure on control column to increase nose wheel steering effectiveness.

Check engine stable operation during takeoff run. Rotate the airplane at VR smoothly to takeoff attitude. After lift-off, smooth flight control inputs should be applied if any tendency in pitch and roll are felt. Use of flight director takeoff sub-mode is recommended (on those certifications which allow the use of flight director during takeoff).

Flight controls forces may be heavier than normal, without causing any difficult in controllability.

Increased V2 procedures (if available in the approved AFM) may be used if runway length is not a limiting factor.

SOP-145/1489

REVISION 5

2-75	Page 13	Code 01
------	------------	------------



AFTER TAKEOFF

CHALLENGE ACTION PERFORMED BY

Ice Protection Test (if applicable)..... COMPLETE PF & PM

Ice Detection Override Knob..... AUTO PM

Monitor weather conditions for an encounter with ice for the remainder of the flight. Closely monitor the static air temperature indication so that when moisture is present, a look at the windshield and windshield wiper will indicate if ice is accumulating. Notwithstanding installation of the ice detector, the crew remains responsible for monitoring icing conditions and for manual activation of the ice protection system whenever necessary.

IgnitionAS REQUIRED PF

CLIMB/CRUISE

If engine vibration increases, advance thrust levers, one at a time, to obtain 60% N1 minimum for 5 seconds, and then return to the former setting.

If ITT increases beyond limits, reduce Thrust Levers as required to maintain ITT within limits.

When flying in icing conditions or after flying in icing conditions, ice accretion on unprotected areas may cause vibration at high speeds. If vibration and/or buffeting occurs, a change in the current airspeed will eliminate these effects. At high speeds reduce the airspeed as required, limited to a minimum of 200 KIAS. Observe normal (including operation in icing conditions) procedures contained in the approved AFM.

No special technique is required to fly with the autopilot on or off. Climb using FLC mode provides enough speed margin to stall. SPD and VS modes may also be used, provided that the airspeed is not allowed to decrease below 200 KIAS (when flying IAS) or 0.56 M (when flying Mach). During autopilot operation, monitor pitch attitude and speed continuously.

If BLD 1 (2) LOW TEMP message appears, advance Thrust Lever until the message disappears and check bleed temperature pointer (MFD ECS and Pneumatic page) in the green range.

2-75	Page 14	Code 01
------	------------	------------

REVISION 4

User: aherrera - Printed By myTechCare - Aug 09/22 - 14:17:22

During cruise, observe minimum fuel tank temperature (-40°C). If fuel temperature is reaching the limit, apply the FUEL LOW TEMPERATURE procedure in the AFM.

HOLDING

CHALLENGE	ACTION	PERFORMED BY
Landing Gear	UP	PM
Flaps	UP	PM
Minimum Airspeed	200 KIAS	PF

CAUTION: MAINTAIN A MINIMUM AIRSPEED OF 200 KIAS SINCE EVEN SMALL ACCUMULATIONS OF ICE ON THE WING LEADING EDGE MAY CHANGE THE STALL CHARACTERISTICS OR THE STALL PROTECTION SYSTEM WARNING MARGIN.

DESCENT

Observe normal (including operation in icing conditions) procedures contained in the approved AFM.

When using the autopilot, monitor pitch attitude and speed continuously.

If approaching the terminal area in icing conditions, an increased rate of descent may be necessary. In this case, a combination of flaps set at 9° and speed brakes open may be used.

NOTE: Engine and Wing Ice Protection Systems operation is automatic and based on the primary ice detection system. However, the crew remains responsible for monitoring icing conditions and for manual activation of the ice protection system if icing conditions are present and the ice detection system is not activating the ice protection system.

APPROACH AND LANDING

Observe normal (including operation in icing conditions) approach/landing procedures contained in the approved AFM.

When landing below -40°C (-40°F), ensure that rate of descent before touchdown is less than 300 ft/min. After landing, report to the maintenance personnel.

User: aherrera - Printed By myTechCare - Aug 09/22 - 14:17:22

SOP-145/1489



NOTE: During approach and landing with engines and anti-icing system on, the FADEC logic automatically reduces the Flight Idle thrust when landing gear is lowered. On airplanes equipped with an EICAS version earlier than the 16.5, the WG 1(2) A/ICE FAIL, WG A/ICE ASYMMETRY and/or STAB A/ICE FAIL messages may be presented due to low bleed pressure available. If these messages appear, the OPEN inscription on the buttons may still be illuminated. To avoid those messages from appearing, it is recommended to maintain a minimum of 55% N1 during descent and landing phases when landing gear is down. Reducing N1 below 55% is recommended only when needed for landing.

LANDING ON WET OR SLIPPERY RUNWAYS

Refer to section 3-40 for guidance and techniques regarding landing on Wet or Slippery Runways.

TAXI IN AND PARKING

CHALLENGE ACTION PERFORMED BY

Ice Detection Override Knob.....ENG RSP

NOTE: Make sure the flaps are free from snow, ice or slush.

FlapsUP RSP

CAUTION: TAXI AT REDUCED SPEED IN ICE-COVERED RUNWAYS TO AVOID SKIDDING THE AIRPLANE.

THROUGH FLIGHTS

CHALLENGE ACTION PERFORMED BY

Doors and Windows CLOSE ...LSP & RSP

Whenever possible, to maintain the cabin warm, keep the passenger, baggage and service doors closed at intermediate stops.

APU ON RSP

APU should be on to provide bleed air to maintain cabin warm.

2-75	Page 16	Code 01
------	------------	------------

CHALLENGE	ACTION	PERFORMED BY
Air Conditioning Packs	ON	RSP
Recirculation Fans.....	ON	RSP

Walk around the airplane and check the following items:

Fuselage, Wing, Tail and Control

Surfaces FREE OF FROST, ICE OR SNOWRSP

Pitot Tubes/TAT/Static Ports

and AOA Vanes..... CHECKRSP

Check clear of ice and residual deicing and anti-icing fluids.

Engine/APU Air Inlet CLEAR OF ICE OR SNOWRSP

Landing Gear..... CLEAR OF ICE, UNOBSTRUCTEDRSP

Air Conditioning Inlets/Outlets.....CLEAR OF ICERSP

Fuel Tank Vents CLEAR OF ICE OR SNOWRSP

Ask for deice/anti-ice fluid application, if necessary.

User: aherrera - Printed By myTechCare - Aug 09/22 - 14:17:22



LEAVING THE AIRPLANE - SECURING FOR COLD SOAK OR AN EXTENDED PERIOD

CHALLENGE	ACTION	PERFORMED BY
-----------	--------	--------------

The procedures below should be performed in the event of extended airplane exposure at low temperatures. In the event that the airplane is off the maintenance base, the crew should ensure that all actions have been accomplished.

Wheel Chocks..... CHECK IN PLACE RSP

Emergency/Parking Brakes.....AS REQUIREDLSP

For an icy ramp, leave Emergency/Parking Brakes applied. Otherwise, Emergency/Parking Brakes must not be applied to avoid freezing of the brakes.

Pitch Trim.....FULL NOSE DOWN RSP

As high precipitation may occur during overnights, it is recommended that pitch trim be left at full nose down position.

Gust Lock..... LOCKEDLSP

Protective Covers..... INSTALLED RSP

Water and Waist SystemCHECK DRAINED RSP

Drain water and waste from all water tanks, if cold soak temperature is expected to be below 0°C (32°F).

Batteries.....CHECK REMOVED RSP

As the batteries may not fully recharge under very low temperatures, batteries should be removed whenever the temperature forecast during the overnight is below -15°C (5°F).

Doors and WindowsCHECK CLOSED RSP

All doors and windows must be closed to prevent snow and humidity from entering into the airplane.

User: aherrera - Printed By myTechCare - Aug 09/22 - 14:17:22

2-75	Page 18	Code 01
------	------------	------------

GENERAL REMARKS WHEN FLYING IN ICING CONDITIONS

- Continuously monitor engine parameters, airplane pitch attitude and airspeed.
- Closely monitor the TAT indication and presence of moisture. If environmental ice conditions exist, even intermittent, check the windshield, windshield wiper (if installed), and wing surface for ice accumulation. To visualize ice formation, if necessary, use a flashlight on the windshield and the wing inspection light on the wing. If any ice formation is detected or suspected, select the anti-ice protection system override knob to ALL. When flying in detected or suspected ice conditions, use ice speeds as reference.
- Be careful for any mistrimmed condition that may be masked by the autopilot - keep the airplane trimmed at all times. Consider turning the autopilot off if you suspect you are flying in severe icing conditions.
- Monitor anti-ice systems for proper operation. Apply the associated AFM abnormal procedure in case of system failure. If the failure persists, exit and avoid icing conditions. Make the air traffic controller know you are requesting a change due to icing conditions and keep him informed about it.
- Strictly follow AFM Operation In Icing Condition normal procedures.
- Avoid landing in an airport where icing conditions exist or are anticipated if anti-ice system, brakes, thrust reverse, ground spoilers, nosewheel steering or flight controls have failed.
- Do not hesitate to leave icing conditions when icing cannot be handled, even with anti-ice system operating properly.

NOTE: Engine and Wing Ice Protection Systems operation is automatic and based on the primary ice detection system. However, the crew remains responsible for monitoring icing conditions and for manual activation of the ice protection system if icing conditions are present and the ice detection system is not activating the ice protection system.

User: aherrera - Printed By myTechCare - Aug 09/22 - 14:17:22



INTENTIONALLY BLANK

User: aherrera - Printed By myTechCare - Aug 09/22 - 14:17:22

2-75	Page 20	Code 01
------	------------	------------

LIGHTNING STRIKE

ON GROUND OPERATIONS

IF THE AIRPLANE HAS BEEN HIT BY LIGHTNING:

External Safety Inspection

CHALLENGE	ACTION	PERFORMED BY
-----------	--------	--------------

Holes, Punctures, Discoloration and De-lamination throughout the Whole Airframe	CHECK	LSP
--	-------	-----

Loose, Melted or Missing Rivets	VERIFY	LSP
Verify that there are no loose, melted or missing rivets.		

Static Dischargers	NUMBER AND CONDITION	LSP
---------------------------------	----------------------	-----

Landing and Taxi Lights	CONDITION	LSP
Clean and undamaged.		

Wing Inspection, Landing and Taxi Lights	CONDITION	LSP
Clean and undamaged.		

Navigation, Strobe and Red Beacon Lights	CONDITION	LSP
Clean and undamaged.		

AOA Vanes/TAT Sensor/Ice Detectors	CHECK	LSP
Verify condition with no obstructions, covers or damage.		

Radome	CHECK	LSP
---------------------	-------	-----

**Maintenance proceed is in
accordance with AMM MPP 05-50-01
before the airplane next flight** CONFIRM LSP

SOP-145/1489

REVISION 4

2-77	Page 1	Code 01
------	-----------	------------

User: aherrera - Printed By myTechCare - Aug 09/22 - 14:17:22

IN FLIGHT OPERATIONS

IF A LIGHTNING STRIKE IS LIKELY TO OCCUR:

Indication of imminent lightning strike event:

- Buildup of static discharge which causes interference on ADF indicators or noise in communication receivers.
- Elmo's Fire, which is visible at night as small electrical discharges running across the windshields and sparking on the wings.

CHALLENGE	ACTION	PERFORMED BY
Penetration of Thunderstorm	AVOID	PF
Visual Contact with Thunderstorm and Lightning.....	MAINTAIN	PF
Weather Radar.....	CHECK FOR PRECIPITATION	PF

Remember that radar detects only liquid droplets, not the cloud itself.

Thundercloud Detected.....CIRCUMNAVIGATE PF

Circumnavigate the detected thundercloud or area by 25 miles or more when traffic conditions permit.

All Cockpit Lights..... ON/FULL BRIGHTNESS PF & PM

Sunglasses CONSIDER WEAR PF & PM

Consider wearing sunglasses to protect your eyes from the flash or have one pilot keep eyes downward.

IF THE AIRPLANE HAS BEEN HIT BY LIGHTNING:

Apply the associated emergency/abnormal procedure if any failure arises after a lightning strike. If the situation is under control after a lightning strike, apply the following procedure to ascertain whether the flight may proceed safely.

CHALLENGE	ACTION	PERFORMED BY
Altitude	MAINTAIN	PF

If not required by performance, obstacle clearance or operational contingencies, stop climbing during airplane check.

Circuit Breakers	CHECK	PF & PM
-------------------------------	--------------	--------------------

Compass/Heading System	CHECK	PM
-------------------------------------	--------------	-----------

Check magnetic compass and heading system for normal indications.

Engine Indication	CHECK	PM
--------------------------------	--------------	-----------

Check engine for normal indications. In case of engine shutdown, the flight crew shall analyze the circumstances of the event and consider an engine airstart.

Pressurization	CHECK	PM
-----------------------------	--------------	-----------

Check pressurization system for normal indication.

If loss of pressurization is presented, structural damage may be considered. In this case, the associated procedure must be accomplished.

Flight Controls	CHECK	PF
------------------------------	--------------	-----------

Check all flight controls for freedom of movement. Verify that flaps and speed brakes are working properly (refer to flaps and speed brakes operating limits).

Fuel System	CHECK	PM
--------------------------	--------------	-----------

Check fuel system for normal operation. Monitor fuel remaining and fuel consumption to ascertain that no fuel leak exists.

All Other Airplane Systems	CHECK	PM
---	--------------	-----------



Check all airplane instruments following a panel scan sequence to ascertain that flight safety prevails.

The display colors may be changed, however the display information remains valid.

Communication SystemsCHECK PM

Apply the associated emergency/abnormal procedure if any failure arises after a lightning strike. Consider discontinuing the flight and land at the nearest suitable airport if any unsafe condition is revealed after checking system operation and general airplane condition.

AFTER LANDING

Lightning

Strike EventREPORT TO MAINTENANCELSP

Report the lightning strike to maintenance personnel, by filling out the LIGHTNING STRIKE INCIDENT REPORT form.

User: aherrera - Printed By myTechCare - Aug 09/22 - 14:17:22

2-77	Page 4	Code 01
------	-----------	------------

TURBULENT AIR PENETRATION

Flight through severe turbulence must be avoided, if possible.

If not possible, reduce altitude to increase buffet margin.

The recommended procedures for turbulent air penetration are:

1. AIRSPEED

At or Below 10000 ft 200 KIAS
 Above 10000 ft.....250KIAS/0.63 M
 WHICHEVER
 IS LOWER

Severe turbulence will cause large and often rapid variations in indicated airspeed. Do not chase the airspeed.

2. ATTITUDE

Maintain wings level and proper pitch attitude. Use attitude indicator as the primary instrument. In extreme drafts, large attitude changes may occur. Do not use sudden large control inputs.

3. PITCH TRIM

Maintain control of the airplane with the elevators. After establishing the trim setting for penetration speed, do not change pitch trim.

4. ALTITUDE

Large altitude variations are possible in severe turbulence. Sacrifice altitude in order to maintain the desired attitude. Do not chase altitude.

5. THRUST SETTING

Make an initial thrust setting for the target airspeed. Change thrust setting only in case of extreme airspeed variation.

In case of inadvertent negative-g condition, reduce thrust levers.

Do not extend flaps except for approach and landing.

User: aherrera - Printed By myTechCare - Aug 09/22 - 14:17:22



INTENTIONALLY BLANK

User: aherrera - Printed By myTechCare - Aug 09/22 - 14:17:22

2-80	Page 2	Code 01
------	-----------	------------

Copyright © by Embraer. Refer to cover page for details.

REVISION 4

SOP-145/1489

WINDSHEAR

INDICATION: WDSHEAR on PFD (red or amber)

AURAL WARNING: WINDSHEAR voice message is generated if WDSHEAR red indication is presented and CAUTION WINDSHEAR voice message is generated if WDSHEAR amber indication is presented (GPWS warning may also be activated).

CONDITION: Airplane loses altitude after windshear is encountered and threat of ground contact exists.

CHALLENGE	ACTION	PERFORMED BY
Thrust Levers	MAX	PF
Go-Around Buttons	PRESS	PF

Rotate the airplane smoothly to minimize altitude loss. Flight guidance on EADI must be followed.

NOTE: Pitch attitude may be well above normal angles.

Maintain airplane configuration. Do not change gear and flap position until terrain clearance is assured and above 1500 ft AGL or after WDSHEAR label is removed from PFD.



INTENTIONALLY BLANK

User: aherrera - Printed By myTechCare - Aug 09/22 - 14:17:22

2-83	Page 2	Code 01
------	-----------	------------

Copyright © by Embraer. Refer to cover page for details.

REVISION 4

SOP-145/1489

SECTION 3

PROCEDURES AND TECHNIQUES

TABLE OF CONTENTS

	Block	Page
General	3-05-01	01
Philosophy of Operation	3-05-05	01
Safety Priority	3-05-05	01
Team Mentality	3-05-05	01
Captain's Authority	3-05-05	01
Use of Automation	3-05-05	01
Areas of Responsibility	3-05-05	02
Dark and Quiet Cockpit Concept.....	3-05-05	02
Briefings.....	3-05-05	02
Communications.....	3-05-05	02
Buttons Concept.....	3-05-05	02
Checklist Philosophy	3-05-05	03
Normal Checklist	3-05-05	03
Emergency/Abnormal Procedures	3-05-05	04
Non-Annunciated Procedures	3-05-05	05
Smoke Procedures	3-05-05	05
Monitoring of Operational Performance	3-05-05	06
Legal Coverage	3-05-05	06
Security Issues	3-05-05	07
Operating Policies	3-05-10	01
Crew Coordination.....	3-05-10	01

	Block	Page
Automatic Flight	3-05-10	01
Use of the Flight Director	3-05-10	02
Use of the CDU	3-05-10	02
Use of the Autopilot	3-05-10	03
Weather Radar	3-05-10	03
PFD/EICAS	3-05-10	03
TCAS	3-05-10	03
Windshear	3-05-10	06
Areas of Responsibility	3-05-10	07
Communications	3-05-10	09
Briefings	3-05-10	10
Flight Deck Access	3-05-10	10
Meals	3-05-10	10
Shoulder Harness	3-05-10	10
Headphones	3-05-10	11
Lights	3-05-10	11
Pilot Incapacitation	3-05-10	11
Approaches	3-05-10	12
Brakes Usage	3-05-10	12
Thrust Reverser	3-05-10	12
Tow Bar	3-05-10	12
Ground Operations	3-10	01
Engine Start	3-10	01
Engine Warm Up	3-10	01

	Block	Page
Icing, Cold Weather and Cold Soak Conditions	3-10	01
Use of APU	3-10	05
Push Back	3-10	07
Flight Controls Check	3-10	07
Taxi	3-10	09
General	3-10	09
Taxi Speeds and Braking	3-10	09
Influences on Tire Wear	3-10	11
Thrust Use During Taxi	3-10	11
Rudder/Steering Use and Turning Radius	3-10	12
Single Engine Taxi	3-10	16
Taxi Under Adverse Weather	3-10	17
Engine Fire (On Ground)	3-10	18
Emergency Evacuation	3-10	20
Takeoff	3-15-01	01
General	3-15-01	01
Flap Retraction	3-15-01	02
Takeoff Actions and Callouts	3-15-01	06
After Takeoff Actions and Callouts	3-15-01	08
Rejected Takeoff - RTO	3-15-05	01
Crosswind Takeoff	3-15-05	04
Tail Wind Takeoff	3-15-05	04
Tail Strike Considerations	3-15-05	04
Noise Abatement Procedures	3-15-05	05

User: aherrera - Printed By myTechCare - Aug 09/22 - 14:17:22

	Block	Page
Takeoff in Adverse Conditions.....	3-15-05.....	10
Windshear.....	3-15-05.....	10
Engine Failure.....	3-15-10.....	01
Flap Retraction	3-15-10.....	03
Engine Failure at or Above V ₁ Actions and Callouts	3-15-10.....	04
Engine Fire, Severe Damage or Separation (On Takeoff After V ₁) Actions and Callouts	3-15-10.....	12
Climb.....	3-20.....	01
General	3-20.....	01
Initial Climb	3-20.....	02
Climb Profile and Considerations	3-20.....	03
Climb Based on Vertical Green Modes (FD)	3-20.....	03
Climb Based on Vertical Magenta Modes (VNAV, If Applicable)	3-20.....	04
Climb Speeds.....	3-20.....	06
Enroute Climb	3-20.....	07
Cabin Differential Pressure.....	3-20.....	08
Engine Ice Climb.....	3-20.....	08
One Engine Inoperative Climb.....	3-20.....	09
Cruise.....	3-25.....	01
General	3-25.....	01
Speed Selection.....	3-25.....	01
Cruise Speed Management.....	3-25.....	01
Altitude Selection	3-25.....	02
Cruise – Flight Level Table	3-25.....	02
Wind Altitude Trade	3-25.....	03
Flight Controls Trimming.....	3-25.....	03

3-00	Page 4	Code 01
------	-----------	------------

	Block	Page
Fuel Imbalance	3-25	04
Throttle Technique.....	3-25	05
Turbulent Air Penetration.....	3-25	05
Driftdown.....	3-25	06
RVSM	3-25	12
Emergency Descent	3-25	13
Unreliable Airspeed	3-25	17
Airplane Upset.....	3-25	18
Upset Prevention.....	3-25	18
Upset Recovery.....	3-25	19
Nose High Recovery Maneuver	3-25	20
Nose Low Recovery Maneuver	3-25	22
Stall.....	3-25	24
Approach to Stall	3-25	26
Full Stall.....	3-25	26
Stall Recovery Maneuver	3-25	26
Descent.....	3-30	01
General	3-30	01
Descent Speeds	3-30	01
Initial Distance to Descent.....	3-30	02
Green Mode.....	3-30	04
Descent Based on Vertical Magenta		
Modes (VNAV, If Applicable).....	3-30	05
Magenta Mode.....	3-30	07
Actions and Callouts.....	3-30	08
Ice Condition.....	3-30	09
RNP 0.3	3-30	09
Holding.....	3-32	01

	Block	Page
General	3-32	01
Holding in Icing Conditions	3-32	02
One Engine Inoperative Holding	3-32	03
Approach	3-35-01	01
General	3-35-01	01
Fuel Consumption	3-35-01	01
Instrument Approaches	3-35-01	03
Landing Speeds	3-35-01	07
Initial Approach	3-35-01	10
Procedure Turn	3-35-01	12
Malfunctions	3-35-01	12
Precision Procedures	3-35-01	13
Actions and Callouts	3-35-01	14
ILS CAT I	3-35-01	19
Steep Approach	3-35-01	19
ILS CAT II/III	3-35-01	22
Descent and Precision Approach Actions and Callouts	3-35-01	23
Intercepting Glideslope From Above	3-35-01	28
Low Visibility Approach	3-35-05	01
Low Visibility Approach Actions and Callouts	3-35-05	04
One Engine Inoperative Precision Approach	3-35-05	11
Non Precision Procedures	3-35-10	01
Descent and Non-Precision Approach Actions and Callouts	3-35-10	06
One Engine Inoperative Non Precision Approach	3-35-10	13
Circling Approach	3-35-10	15
One Engine Inoperative Circling Approach	3-35-10	17

3-00	Page 6	Code 01
------	-----------	------------

	Block	Page
Visual Approach	3-35-10.....	19
One Engine Inoperative Visual Approach	3-35-10.....	21
Go-Around	3-35-10.....	23
One Engine Inoperative Go-Around	3-35-10.....	26
Abnormal Flap Configuration.....	3-35-10.....	29
EGPWS Warning Corrective Maneuver	3-35-10.....	30
Landing	3-40.....	01
General	3-40.....	01
Landing Procedure	3-40.....	01
Brakes Usage	3-40.....	04
Maximum Performance Landing	3-40.....	05
Landing on Wet, Slippery or Contaminated Runways..	3-40.....	06
Crosswind Landing	3-40.....	07
Operational Factors Affecting Landing Distance	3-40.....	08
Recovery From Offset Position	3-40.....	09
Windshear	3-40.....	11
Low Visibility Landing	3-40.....	14
Rejected Landing.....	3-40.....	14
Bounced Landing.....	3-40.....	16
Tail Strike During Landing	3-40.....	17
Overweight Landing.....	3-40.....	18
Touch and Go Landing	3-40.....	19
Ditching.....	3-40.....	22
Forced Landing.....	3-40.....	27

User: aherrera - Printed By myTechCare - Aug 09/22 - 14:17:22

INTENTIONALLY BLANK

3-00

Page
8

Code
01

REVISION 10

GENERAL

ABNORMAL

When abnormal is used to describe a procedure or checklist, it refers to a non-routine operation in which certain procedures or actions must be taken to maintain an acceptable level of airworthiness for a continued safe flight and landing. When associated with a **caution condition** message, it will indicate procedures that may result in damage to equipment if not followed. The abnormal procedures have been written assuming oxygen masks will be donned and communications established between crewmembers whenever oxygen deficiency or contamination is suspected.

ACCELERATION ALTITUDE

It is defined as Level off Altitude on the Runway Analysis performance chart. It is the takeoff 3rd segment and is used for level flight, acceleration and flap retraction. The acceleration altitude varies between 400 ft and 1500 ft according to the takeoff path, obstacles and engine limitations.

ADVISORY

Used to indicate a condition that requires crew awareness and may require subsequent or future crew action.

AFE

Above Field Elevation.

APPROACH SEQUENCE

Actions to be performed by the Pilot Monitoring upon Pilot Flying request during the approach phase.

AREAS OF RESPONSIBILITY

Cockpit areas operated by a specific pilot. These areas exist to improve crew coordination and a pilot must always advise the other pilot if he is intending to operate something outside his Area of Responsibility. Refer to the Operating Policies section to determine what areas are assigned to which pilot.

REVISION 5

3-05-01	Page 1	Code 01
---------	-----------	------------

ASAP

Aviation Safety Action Program encourages voluntary reporting of mistakes and incidents by promising no reprisals.

AUTOMATION COMPLACENCY

Failure to monitor airplane systems due to overconfidence in automation.

CABIN CREW

Crewmembers that report to the Pilot-in-Command and are in charge of assuring the safety of the occupants that are not crewmembers in all circumstances. The cabin crew is composed of Flight Attendants.

CALLOUTS

Callouts are aids in maintaining awareness of the crew as to the status of given tasks. They are extremely important in aiding situational awareness. They are made to indicate that a system has deviated from the assigned parameters or to describe tasks or events requiring a high level of monitoring of highly dynamic and unstable events.

CAPTAIN OR PILOT IN COMMAND

The pilot that is legally responsible for the operation of the airplane and who commands the operation of the airplane. He has the authority to take actions, to request or to delegate any crewmember action as he finds appropriate to ensure the safety of the flight.

CAUTION

Used to indicate a hazard that if ignored could result in damage to an airplane component or system which would make continued safe flight improbable (Immediate crew awareness and subsequent corrective or compensatory crew action required).

CLIMB SEQUENCE

Actions to be performed by the Pilot Monitoring upon Pilot Flying request during initial climb phase.

3-05-01	Page 2	Code 01
---------	-----------	------------

CRITICAL PHASES OF FLIGHT

High workload phases of flight. Flight phases below FL100 (not including cruise flights), Takeoffs, Final Approach, Missed Approach, Landings, including landing roll, Taxi procedures and all parts of the flight operation considered as critical by the flight crew.

CRM

Crew Resource Management is the effective use of all resources to include human and other aviation system resources.

ACRM

Advanced Crew Resource Management - a package including CRM procedures, training of the instructor/evaluators, training of the crews, a standardized assessment of crew performance, and an ongoing implementation process providing an integrated form of CRM by incorporating CRM practices with normal and emergency SOP.

DARK AND QUIET COCKPIT

A concept used to design and operate an airplane based on the assumption that in flight all systems are normal when the overhead, main, glareshield and control pedestal panels have no lights on, and no aural warnings are taking place. This concept enforces the need of a quiet environment inside the cockpit during most phases of flight.

DO AND VERIFY

A checklist usage technique that consists of completing all the checklist actions by memory and verifying them afterwards by reading and replying.

ELECTRONIC FLIGHT BAG (EFB)

The EFB is an electronic device (notebooks, tablets, etc) that can support different applications such as electronic documents, charts, checklists and performance related applications.

EMERGENCY

When emergency is used to describe a procedure or Checklist, it refers to a non-routine operation (warning) in which certain procedures or actions must be taken to protect the crew, passengers or the airplane from a serious hazard or potential hazard. When associated with a warning EICAS message, it will indicate procedures that may result in personal injury or loss of life if not followed. The emergency procedures have been written assuming oxygen masks will be donned and communications established between crewmembers whenever their use is required.

EXPANDED PROCEDURES

A description of sequential procedural steps with detailed explanations and/or instructions accompanying each step.

FIRST OFFICER (FO) OR SECOND IN COMMAND (SIC)

A pilot that is not in command but can carry out the duty of flying the airplane under the circumstances established by company rules.

FLIGHT ATTENDANT

Crewmember that reports to the Pilot-in-Command and is in charge of assuring the safety of the occupants that are not crewmembers in all circumstances. The **Purser** is the flight attendant responsible for coordinating with other flight attendants the efficient handling of non-crewmember occupants. The **Purser** must handle all relevant matters needing coordination with the flight crew.

FLIGHT CREW

Crewmembers that conduct the airplane's flight operation. The flight crew will be composed of Captain and First Officer.

FOQA

Flight Operations Quality Assurance, monitors flight data recorder in order to monitor safety issues. New generation airplanes flight recorder data are monitored for airplane performance exceeding specific limits. There is no jeopardy to flight crews' jobs.

3-05-01	Page 4	Code 01
---------	-----------	------------

IMMEDIATE ACTION

An action that must be taken in response to a non-routine event so quickly that reference to a checklist is not practical because of a potential loss of airplane control, incapacitation of a crewmember, damage to or loss of an airplane component or system, which would make a continued safe flight improbable.

INSTRUCTOR PILOT

A pilot that acts as Flight Instructor to a not-yet qualified pilot or to a qualified pilot undergoing flight instruction for refreshment or for any other reason.

LAND AT THE NEAREST SUITABLE AIRPORT

Some checklists require landing at the nearest suitable airport. This statement may be presented below the associated emergency/ abnormal characterization or at the beginning of a task that requires so. When the crew determines that significant threat to safety is present, they should always accomplish the earliest possible descent, land at the nearest suitable airport regardless of having this statement present in the checklist.

LOFT

Line Oriented Flight Training: simulator training session where the focus is on reproducing an environment as similar as possible to the airline operating environment with similar workload and routine. The objective of these sessions is to identify areas of difficulty related to crew coordination and ergonomics. LOFT sessions may include abnormal and emergency situations that require knowledge-based actions by the crew.

LOSA

Line Operations Safety Audit: provides a process for analyzing the safety of normal line operations. Rather than focusing on events and finding fault, it offers a systemic and non-punitive assessment by trained observers of everyday operational flights. The LOSA process consists of a family of methodologies. In addition to the observations, crewmembers are interviewed and complete questionnaires on safety practices, organizational culture and cockpit management.

MAXIMUM PERFORMANCE LANDING

Maximum Performance Landing is a set of techniques that leads to stop the airplane within minimum landing distance.

MEMORY ITEMS

Items of the checklist that must be memorized by the flight crew and whose execution must be carried out immediately should the corresponding checklist become applicable (immediate action). Memory items should be verified after completion.

NON-ANUNCIATED

When Non-Annunciated is used to describe a procedure or checklist, it refers to a non-routine operation requiring flight crew action, due to a condition not capable to be sensed by the airplane avionics system (e.g.: Smoke, Emergency Descent, etc.)

OBSERVER

Person (crewmember or check airman) sitting on the jump seat.

PILOT FLYING (PF)

Pilot who is controlling the path and thrust setting of the airplane in flight (it is the primary responsibility of each pilot to monitor the airplane).

PILOT INCAPACITATION

A situation where one of the pilots is not able to perform his duties.

PILOT MONITORING (PM)

Pilot who is actively assisting/monitoring Pilot Flying during operation of the airplane. The active monitoring concept must be implemented, trained, practiced and must have its effectiveness evaluated in order to provide benefits. It is the primary responsibility of each pilot to monitor the airplane and the other pilot.

PRECISION-LIKE APPROACH

Technique to fly all non precision approaches with a stabilized vertical descent path to the runway end.

3-05-01	Page 6	Code 01
---------	-----------	------------

RAPID DEBOARDING

There are situations that require passengers to leave the airplane in an expeditious manner but do not justify an Emergency Evacuation. In these cases the Pilot In Command may command a Rapid Deboarding procedure.

Rapid Deboarding consists of leading the passengers out of the airplane by using normal means of deboarding such as stairways or jetways.

READ AND DO

A checklist usage technique that consists of reading and accomplishing each of the checklist items. The Checklist items will follow the sequence corresponding to the sequence of actions required.

REJECTED TAKEOFF

A takeoff that is discontinued after takeoff thrust is set and initiation of the takeoff roll has begun.

SILENT CHECKLIST

Performed during high workload periods. The procedure reduces the amount of activity on the flight deck that the pilots normally have to contend with. The crewmember executing the checklist should announce "_____ Checklist completed" when all checklist items have been accomplished.

The only silent checklist is the After Takeoff.

SITUATIONAL AWARENESS

Refers to the fact that the crew should be conscious of the airplane's condition under specific operational and environmental circumstances.

SPEEDS

- Approach Climb Speed ($V_{APP\ CLB}$) – It is the speed to be used in case of a single engine go-around with Go-around Flaps and Landing Gear retracted.
- Approach Speed (V_{APP}) – It is the speed on the final approach, in landing configuration.
- Decision Speed (V_1) – It is the speed in the takeoff which the pilot must take the first action to stop the airplane within the accelerate-stop distance, V_1 also means the minimum speed in the takeoff, following a failure of the critical engine, at which the pilot can continue the takeoff and achieve the required height above the takeoff surface within the takeoff distance.
- Landing Reference Speeds (V_{REF}) – It is a reference for V_{APP} calculation. It is the minimum recommended speed at 50 ft over the threshold. It is the speed used in the landing distance calculations.
- Final Segment Speed (V_{FS}) – It is the speed to be achieved during the final takeoff segment, with landing gear up and flaps retracted.
- Rotation Speed (V_R) – The speed at which the pilot initiates action to raise the nose gear off the ground.
- Takeoff Safety Speed (V_2) – The speed attained at the screen height (e.g. 35 ft), assuming one engine inoperative and rotation initiated at V_R .

STABILIZED APPROACH

Criteria used to judge an approach according to the capability of the airplane to perform a safe landing after a determined point at the approach procedure (on the Approach speed plus applicable additives, on the proper flight path, on the proper sink rate and with thrust stabilized no lower than 1000 ft AFE when operating IMC and 500 ft AFE for VMC operations).

STATUS

Used to indicate a condition that requires cockpit indications, but not necessarily as part of the integrated warning system.

3-05-01	Page 8	Code 01
---------	-----------	------------

STERILE COCKPIT

Sterile Cockpit is the establishment of an environment at the cockpit in which the crewmembers can concentrate on airplane operation during certain phases of the flight.

SUPPLEMENTARY PROCEDURES

Used to describe a non-routine procedure that may be employed in addition to a normal procedure. Infrequently used procedures should be performed by reference (read and do).

WARNING

Used to indicate a hazard that if ignored could result in injury, loss of airplane control, or loss of life (immediate corrective or compensatory crew action required).

User: aherrera - Printed By myTechCare - Aug 09/22 - 14:17:22

INTENTIONALLY BLANK

3-05-01

Page
10

Code
01

Copyright © by Embraer. Refer to cover page for details.

REVISION 4

SOP-145/1489

User: aherrera - Printed By myTechCare - Aug 09/22 - 14:17:22

PHILOSOPHY OF OPERATION

SAFETY PRIORITY

Passenger and public safety are the highest priority.

TEAM MENTALITY

The flight and cabin crew must get along as a team. A sense of collaboration and mutual help must prevail for the ultimate objective of safely and efficiently completing the flight.

CAPTAIN'S AUTHORITY

The Captain is ultimately responsible for whatever happens to the occupants, to the airplane or to any goods or persons outside the airplane as result of the flight operation under his command.

The Captain must use crew resources in the most effective way and must encourage the other crewmembers to engage in teamwork by allowing them to participate and give suggestions whenever useful for the execution of the flight. He must treat all crewmembers with respect and consideration at all times.

USE OF AUTOMATION

On highly automated airplanes **monitoring** is as important as **acting**. Monitoring skills and discipline must be enforced and checked during training.

Pilots must be alert and avoid "automation complacency" generated by the highly automated airplane systems. Usage of automation must be well trained in order to provide workload reduction and the ability to correlate the different scenarios and systems.

Monitoring is an active role that should be placed on the same level of importance as in acting, when task sharing is the issue.

The pilot is the most capable component during the flight and he must determine the optimal use of automation.

AREAS OF RESPONSIBILITY

This manual establishes areas in the cockpit that are placed under the responsibility of each specific cockpit crewmember.

Ground operations are divided between the Left Seat Pilot (LSP) and the Right Seat Pilot (RSP) while in-flight operations are divided between Pilot Flying (PF) and Pilot Monitoring (PM). Actions outside the crewmember's area of responsibility may be sometimes applicable and are properly indicated in this manual or are initiated at the discretion of the Captain.

DARK AND QUIET COCKPIT CONCEPT

The design philosophy of the airplane states that under normal flight operation of its systems the pushbuttons and annunciators on the overhead, main, glare-shield and control pedestal panels must be **dark** (no lights).

No visual or aural warnings mean normal operation of the systems.

BRIEFINGS

All members of the crew have the right to be informed regarding matters that affect their functions. Therefore, preflight briefings with the cabin crew are highly recommended, as are in-flight briefings when special non-routine procedures are to be carried out.

COMMUNICATIONS

Non-essential conversation should be avoided during high workload flight phases.

BUTTONS CONCEPT

The normal operating position of the push in/out buttons is identified with no light bar illuminated, regardless of switch position.

Some knobs on the overhead panel have detent protection and must be pulled out to allow knob rotation. Knob stationary positions are marked with a white rectangle, and knob momentary positions are marked with a white triangle. To assure proper signal transmission when using the selector knobs that have momentary positions, hold the knob for at least two seconds at the positions before releasing it.

3-05-05	Page 2	Code 01
---------	-----------	------------

CHECKLIST PHILOSOPHY

The use of the on board checklist is based on the assumption that both pilots have been properly trained on the type of airplane and therefore have a thorough knowledge of the airplane's systems and procedures.

It further assumes that they know the consequences of not performing the right actions at the right time and in the correct order.

The crew should exercise judgment to establish the proper coordination between Normal and Emergency/Abnormal procedures towards the safest course of action.

NORMAL CHECKLIST

The crew must accomplish all the AOM Normal Procedures.

The Normal Checklist is just a memory aid to assist the pilots so they do not forget actions which, if not carried out, can result in some type of **risk** to the airplane, to any of its systems, to its occupants, to the operational environment or can affect passenger comfort. Specific regulations also ask for items to be included in the checklist.

The Normal Checklist has been divided and named according to its specific phase.

In order to reduce the amount of activity in the cockpit during high workload flight phases, After Takeoff checklist will be a Silent Checklist.

In case of interruption the pilot should halt the reading, and when he restarts it he must be sure of where he stopped. If not, the Checklist must be read from start again.

Airplane alerting systems will attract the attention of the crew and direct them to the appropriate action providing means for controlling the status of the systems.

EMERGENCY/ABNORMAL PROCEDURES

MEMORY + READ AND DO

The Emergency/Abnormal Checklist will provide the procedural steps required to resolve non-normal situations on the ground or in flight.

On modern airplanes, situations for which there are no written procedures are likely to occur. It is not possible to develop checklists for every condition, especially when multiple failures occur. Full knowledge of the memory Items is mandatory. Abnormal procedures have been written assuming oxygen masks will be donned and communications established between crewmembers whenever oxygen deficiency or contamination is suspected.

EMERGENCY AND ABNORMAL PROCEDURES HANDLING PHILOSOPHY

- The crewmember recognizing the malfunction calls it out.
 - No action should be taken until the airplane flight path and configuration are properly established and a safe altitude (400 ft or above) has been attained.
 - Procedures have to be initiated on the pilot command.
-
- In case of engine failure, fire, damage or separation at or above V_1 and should there be enough time, the Captain will brief the cockpit crew and Purser:

CAPTAIN → PURSER → FLIGHT ATTENDANTS

In this briefing, the Captain will give the following information:

Time available.

Emergency (type).

Signals conventioned.

Transmit additional instructions (structural damages, restricted exits, loss of landing gear, etc).

3-05-05	Page 4	Code 01
---------	-----------	------------

- When airborne, items referring to throttles, fire handles, generators and engine start/stop selectors should be confirmed by both pilots prior to be accomplished.
- Exercise common sense and caution when accomplishing checklists for multiple failures.
- If more than one EICAS messages appear at same time, the crew should perform the required checklists following the message priority: WARNING (red), CAUTION (amber) and ADVISORY (cyan).
- If more than one EICAS messages, within a category, appear at same time the crew should analyse and define which one should be dealt first.
- In case of abnormal/emergency situation, both crew members systematically and without delay should accomplish all memory items in their area of responsibility.

When the flight is under control and all memory items are completed, the PF calls for the appropriate abnormal/emergency procedure in the QRH.

- After the procedure is completed, the pilot should revert back to the normal checklist, and amend it with the appropriate items requested in the abnormal checklist (e.g. different flap setting). Only the Ditching, Forced Landing and One Engine Inoperative Approach and Landing checklists already incorporate the normal checklists, not requiring a reversion.
- Any time an engine shutdown is needed in flight, good coordination is essential, to avoid shutting down the incorrect engine.

NON-ANUNCIATED PROCEDURES

MEMORY + READ AND DO

The Non-Annunciated checklists describe procedures referring to a non-routine operation requiring flight crew action, due to conditions that are not sensed by the airplane's avionics system such as an emergency descent or emergency evacuation.

SMOKE PROCEDURES

MEMORY + READ AND DO

The Smoke checklists describe procedures associated with malfunctions that lead to a smoke in the cockpit, cabin or cargo compartments condition. The procedures are written with bigger size letters for easier reading.

SOP-145/1489

REVISION 5

3-05-05	Page 5	Code 01
---------	-----------	------------

MONITORING OF OPERATIONAL PERFORMANCE

All efforts must be made to encourage crewmembers to report any difficulty related to human factors. This is fundamental to spot potential flight standard deficiencies before they result in incidents or accidents. Granting confidentiality in this process will respect the importance of these reports. Using reports to correct and improve flight standards is an important process of assuring the quality of flight operation.

Operational difficulties related to human factors observed during simulator sessions, during en route supervision or anytime during normal operation must be collected and a review board of assigned pilots should periodically examine these reports. When the occurrence of a difficulty in statistically significant numbers is detected, this board must suggest changes in the training procedures or in the operating procedures to prevent this difficulty from happening. If it becomes evident that a crewmember or a group of them needs additional training, he or they must be immediately removed from flight duty. FOQA, ASAP and LOSA are examples of quality assurance processes in use worldwide.

**"IF YOU CAN'T MEASURE IT, YOU DON'T KNOW ABOUT IT.
IF YOU DON'T KNOW ABOUT IT, YOU CAN'T FIX IT"**

LEGAL COVERAGE

The Company must provide information regarding legal crewmembers' responsibilities, especially that of the pilot-in-command, when it comes to liabilities resulting from legal violations, incidents and accidents.

The crewmembers must be informed about the legal implications of their acts and statements as well as how to proceed in case of abnormal situations such as in case of incidents and accidents as well as in situations involving law enforcement authorities. The information made available to crewmembers is especially important in case of flights to countries other than the country the company is located at.

Should a legal dispute arise as a consequence of the operation of a company airplane, the company must take all measures to make sure that crewmembers are not unfairly or improperly charged and do not suffer negative consequences that are unduly or unfairly imposed upon them. This company attitude is important to encourage flight crews to act in a rightful rather than in a "trouble-avoiding" manner.

3-05-05	Page 6	Code 01
---------	-----------	------------

SECURITY ISSUES

The flight and cabin crewmembers must be trained to handle unruly passengers or passengers demonstrating offensive or anti social behavior. Additionally, they must be trained to know when special passengers such as deportees and criminals can be accepted on board and on how to proceed in such cases (when to board, request for law enforcement escort, etc.).

User: aherrera - Printed By myTechCare - Aug 09/22 - 14:17:22

SOP-145/1489

REVISION 4

3-05-05	Page 7	Code 01
---------	-----------	------------



INTENTIONALLY BLANK

User: aherrera - Printed By myTechCare - Aug 09/22 - 14:17:22

3-05-05	Page 8	Code 01
---------	-----------	------------

Copyright © by Embraer. Refer to cover page for details.

REVISION 4

SOP-145/1489

OPERATING POLICIES

CREW COORDINATION

The Flight Crew must be trained on coordination with the Cabin Crew.

Cabin crewmembers must understand situations such as sterile cockpit, calls from the cockpit, pilot incapacitation, emergency evacuation, hijacking and other specific in-flight situations where the participation of the Cabin Crew is essential. It is recommended that joint training sessions be carried out to practice this coordination. These joint-training sessions can be LOFT sessions.

These procedures must be trained jointly with Cabin Crew.

AUTOMATIC FLIGHT

Plan to be synchronized with the airplanes' automation. Being "ahead" of the airplane is essential for smooth operation of the automated systems, since auto-flight systems may receive faulty inputs from the flight crew or may contain database errors. When the airplane does not perform as expected, the autopilot must be disconnected and a manual flight promptly established.

The modes selected on the FGC (Flight Guidance Controller) must be monitored on the PFD at all times by both pilots.

USE OF THE FLIGHT DIRECTOR

Flight Director should be used and updated at all times. The PF can request the PM to perform the tasks required to maintain the Flight Director updated with the maneuvers performed.

If the Flight Director is not synchronized with the actual airplane's maneuver it must be updated or turned off.

Removing the FD cue by pressing the FD Button on the FGC (Flight Guidance Controller) does not disengage the Flight Director.

IF NOT USING DESELECT IT

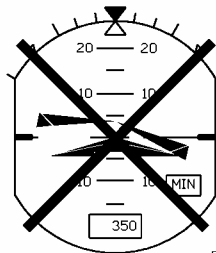
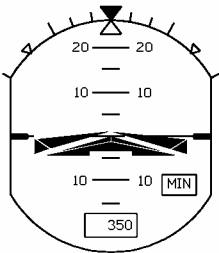

EM145AOM021040A.DGN

USE OF THE CDU

CDU usage must be coordinated in all flight phases (navigation, performance, progress monitoring and changes). Whenever entering a new route, it is the crews' responsibility to check all the waypoints for correct coordinates and associated navigation aids. It is recommended that one pilot enter the flight plan and the other pilot check the data entered.

Below 10000 ft AFE, CDU changes should be made by the PM and executed only after confirmation by the PF. If necessary, revert to basic Autopilot/FD modes to avoid heads down time during high workload flight phases.

3-05-10	Page 2	Code 01
---------	-----------	------------

USE OF THE AUTOPILOT

Pilots should use the autopilot as much as possible, allowing effective monitoring of the flight.

It is recommended the engagement of the autopilot after first vertical mode is engaged and disengagement at traffic pattern altitude for a visual approach or at MDA/DA/DH during an instrument approach (if not performing an auto land or a go around).

The amount of automation to be used during each phase of flight should be determined by the PF.

Pilots must always be alert and monitor the autopilot. Normally high level of automation induces crews to stay out of the loop, with excessive confidence on auto flight systems.

WEATHER RADAR

The weather radar should always be used for night operations and anytime it is necessary at the crews' judgment.

During slaved weather radar operations, the pilot operating the radar should inform any change before its execution, since it will affect the other pilots' presentation as well. If the radar is to be operated in any mode other than STBY while the airplane is on the ground, some restrictions listed in the AOM apply.

PFD/EICAS

Precision approaches should be flown with ILS indications on both sides. VOR and NDB approaches should use some form of raw data to cross check FMS information. RNAV and GPS approaches should always be done after making sure equipment performance is within limits and local regulations were considered.

EICAS messages should always be announced when displayed. When more than one message is displayed careful consideration should be applied in order to prioritize actions.

TCAS

Compliance with TCAS resolution advisory is required unless the pilot considers it unsafe to do so. Maneuvers that are in the opposite direction of the RA are extremely hazardous, especially RAs involving altitude crossing and thus are prohibited unless it is visually determined to be the only means to assure safe separation.

WARNING: IT IS POSSIBLE IN SOME CASES TO HAVE INSUFFICIENT AIRPLANE PERFORMANCE TO FOLLOW THE TCAS COMMAND WITHOUT FLYING INTO STALL WARNING OR BUFFET. CONDITIONS WHERE THIS MAY OCCUR INCLUDE:

- BANK ANGLE IN EXCESS OF 15°.
- OPERATIONS AT AIRPORTS ABOVE 5300 FT MSL OR TEMPERATURES GREATER THAN ISA + 28°C (58°F).
- ENGINE INOPERATIVE.
- FAILURE TO CONFIGURE THE AIRPLANE TO GO-AROUND FOLLOWING A CLIMB RA IN LANDING CONFIGURATION.
- FAILURE TO ADVANCE THRUST TO MAXIMUM CONTINUOUS THRUST FOLLOWING A CLIMB RA AT REDUCED THRUST.
- SPEEDS LESS THAN NORMAL OPERATION SPEEDS.
- ABNORMAL CONFIGURATIONS, WHICH REDUCE PERFORMANCE (E.G. GEAR DOWN).
- TCAS COMMAND REVERSAL TO A “CLIMB-CLIMB NOW”.
- BUFFET MARGIN LESS THAN 0.3 G.

3-05-10	Page 4	Code 01
---------	-----------	------------

ACTIONS AND CALLOUTS		
	PF	PM
Upon receiving TCAS TRAFFIC ADVISORY or a possible conflict is advised by ATC	<ul style="list-style-type: none"> • Place hands on control column and thrust levers to be prepared to react to TCAS resolution. • Scans for visual contact with the intruder. 	<ul style="list-style-type: none"> • Turns all external lights ON. • Communicates with ATC. • Turns FSTN BELTS ON. ⁽¹⁾ • Scans for visual contact with the intruder.
Upon receiving TCAS RESOLUTION ADVISORY	<ul style="list-style-type: none"> • Disengages the Autopilot. • Immediately follows the VSI guidance. 	<ul style="list-style-type: none"> • Monitors the airspeed and altitude and calls PF attention for altitude or airspeed too low or airspeed close to maximum. • Keep scan for visual contact with the intruder.
CLEAR OF CONFLICT	<ul style="list-style-type: none"> • In the absence of an amended clearance, return to the last ATC assigned altitude and course. 	-

⁽¹⁾ Pilot should Turn ON the FSTN BELTS at pilot discretion and/or company police.

WINDSHEAR

The most important policy is to avoid a windshear. Although windshear detection and annunciation system is installed, pilots may not perceive that an area of a potential windshear could be encountered ahead. Therefore some aids must be used by flight crews to develop an awareness of windshear causes and perceive danger signals to successfully avoid it. The following information can be used:

- Presence of thunderstorms, microburst, convective clouds or squall lines;
- Visual observation of strong winds near the ground;
- Onboard weather radar;
- Pilots or Air Traffic Services reports.

User: aherrera - Printed By myTechCare - Aug 09/22 - 14:17:22

3-05-10	Page 6	Code 01
---------	-----------	------------

Copyright © by Embraer. Refer to cover page for details.

REVISION 4

SOP-145/1489

AREAS OF RESPONSIBILITY

ON GROUND

Flow sequence and areas of responsibility for ground procedures. Unshaded areas are under the responsibility of the pilot seated on the respective side. The Left Seat Pilot will handle Communications with ground personnel while the Right Seat Pilot communicates with ATC. Checklists refer to LSP and RSP. Due to the low workload concept, no major actions are expected during taxi. If necessary the pilot not taxiing will perform the required actions.

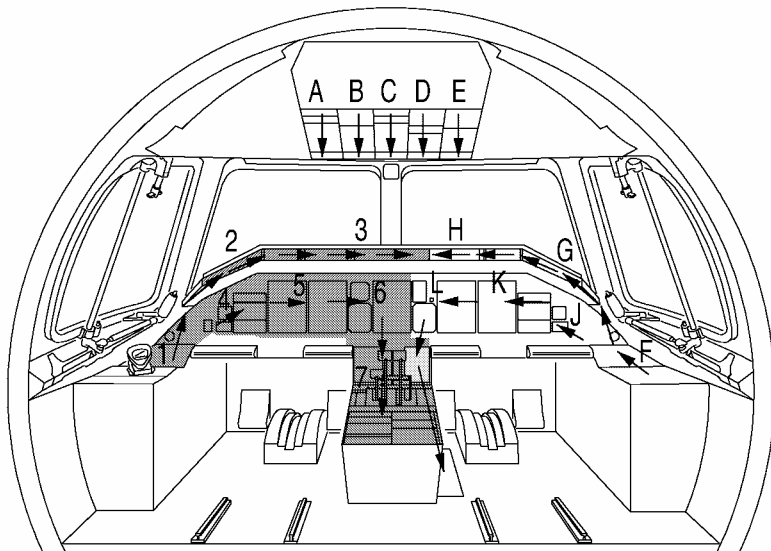

EM145AOM021050A.DGN

The numbers and arrows indicate the recommended flow sequence. The LSP must follow the numbers, and the RSP must follow the letters.

IN-FLIGHT

Flow sequence and areas of responsibility for in-flight procedures with the autopilot engaged. Unshaded areas are under the responsibility of the pilot seated on the respective side. The PM should handle communications. He/she should operate the Flight Guidance Controller, at the discretion of the PF, when the airplane is manually flown. Checklists refer to PF and PM.

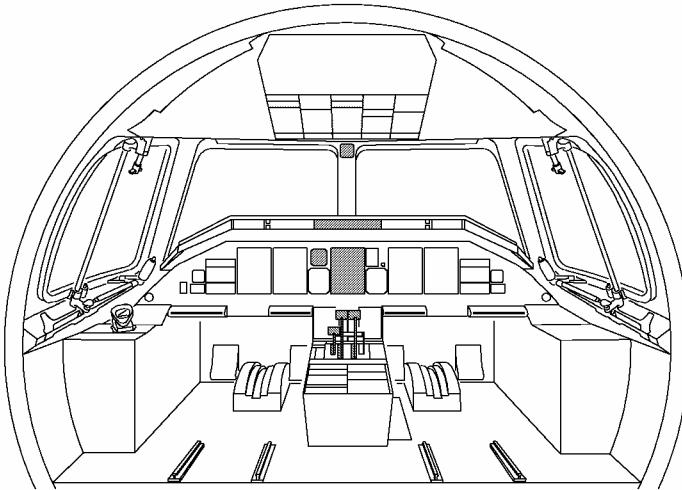

PF  AIRCRAFT THRUST SETTING, FLIGHT PATH AND NAVIGATION.

PNF  CHECKLIST READINGS
COMMUNICATIONS

EM145AOM210003A.DGN

COMMUNICATIONS

Normal communications between the airplane and ATC should be performed by the PM. Whenever the PM is performing a read and do checklist, ATC communications should be performed by the PF in order to minimize interruptions.

Communications from the flight crew to the passengers and between the flight and cabin crew can be performed by any flight crewmember at Captains discretion.

Whenever the Captain believes that an emergency situation can develop into an accident, he will have the flight attendants preparing the cabin for emergency landing over land or water in order to assure maximum safety of the airplane's occupants. Should there be enough time, the Captain will brief the cockpit crew, Purser, and when applicable, cabin supervisors.

CAPTAIN → PURSER → FLIGHT ATTENDANTS

In this briefing, the Captain will give the following information:

Time available.

Emergency (type).

Signals conventioned.

Transmit additional instructions (structural damages, restricted exits, loss of landing gear, etc).

BRIEFINGS

Briefings should be conducted with casual language and personal style to prevent the repetitious use of sentences and terms. Preflight briefings are recommended on the first flight of the day and with any crew changes. Briefings to the cabin crew should include:

- Significant weather.
- Status of relevant airplane systems.
- Refueling.
- Information on the terrain/water to be over flown.
- Flight Routes/Cruising Altitudes/Flight Time/Alternate Airports.
- Special procedures (like hijacking, ditching...).

Takeoff and approach briefings are detailed in the normal procedures.

The Captain must make sure the passengers receive a briefing covering procedures for all flight phases. The cabin crew usually makes that briefing. All special, non-routine operations have to be briefed.

A debrief allows feedback of crew performance and planning of non-critical issues such as airplane servicing. Debriefs also allow closer interaction among crewmembers on future common assignments.

FLIGHT DECK ACCESS

Check local regulations.

MEALS

Each flight crewmember should try to have his/her meal separately. It is recommended that they choose different menus.

SHOULDER HARNESS

Must be on from engine start to transition altitude and from the start of descent until the engines shut down procedures have been finished. Its use is also recommended in the presence of moderate or severe turbulence and any time at crews' discretion.

3-05-10	Page 10	Code 01
---------	------------	------------

HEADPHONES

Use of headphones is mandatory from engine start to the top of climb and from the top of descent until engine shut down.

LIGHTS

NAVIGATION Lights must be ON whenever the airplane is energized. **LOGO** lights must be ON from sunset to sunrise and during low visibility procedures.

RED BEACON must be ON whenever one or more engines are running or during airplane movement.

TAXI (NOSE) light must be ON during airplane ground movement.

STROBE lights must be ON from the moment the airplane enters the runway for takeoff to the point where the airplane leaves the runway after landing.

LANDING lights must be ON for takeoff and landing, when below 10000 ft AFE and inside congested areas.

INSPECTION lights must be used when visual inspection of the wing surfaces is required.

PILOT INCAPACITATION

Pilot incapacitation is a possibility in all age groups and during all flight phases, ranging from sudden death to partial loss of mental or physical performance. Proper crew coordination involves checks and crosschecks using verbal communications and standard operating procedures to detect this problem.

Failure of any crewmember to respond to a second request or a checklist will be considered a pilot incapacitation condition and crew action is immediately required.

CREW ACTION

If one pilot confirms that the remaining pilot is incapacitated, he/she shall take over checking the position of essential controls and switches. An emergency should be declared and the autopilot used to reduce crew workload.

After the autopilot is engaged and the airplane is under control, notify and utilize the cabin crew. If practicable, try to restrain the incapacitated pilot and slide the seat to the full back position. The shoulder harness lock may be used to restrain the incapacitated pilot.

Request assistance from any medically qualified passenger and consider using help from other pilots or crewmembers who may be among the passengers.

Consider landing at the nearest suitable airport.

APPROACHES

The airplane must be on a stabilized approach, that is, on the Approach Speed plus applicable additives, on the proper flight path, with the proper sink rate and with the thrust stabilized no lower than 1000 ft AFE when operating under IMC and 500 ft AFE for VMC operations. A go around is required anytime these criteria are not satisfied.

BRAKES USAGE

In order to reduce carbon brake wear, avoid applying the brakes too often during taxiing “cold brakes” procedures. Wear is far more related to the number of applications than to the energy applied. Carbon brakes wear less when operated at high temperatures.

THRUST REVERSER

Upon landing, if thrust reversers have been used, reverser should be set to MIN REV at 60 kt, and be closed by 30 kt. Full thrust reverser should be used when landing on contaminated runways. During RTO the thrust reverser can be used until the airplane comes to a complete stop.

TOW BAR

If towing is to be performed without trained ground personnel, the pilot is responsible for orienting and following the tow bar installation, correct usage and stowage.

3-05-10	Page 12	Code 01
---------	------------	------------

GROUND OPERATIONS

ENGINE START

Prior to engine start, obtain ATC and ground personnel clearance and, if applicable, check if the jetway is removed and the doors are closed. Engine start may be performed simultaneously with the push back procedure, requiring the parking brake released and disengagement of the steering (verify STEER INOP EICAS message). In case of a static engine start be sure that the parking brake is set. Either engine 1 or engine 2 may be started first.

ENGINE WARM UP

In order to allow thermal stabilization of the engines, operate them at or near to IDLE for at least 4 minutes for cold engines or 2 minutes for warm engines before selecting higher thrust settings. Taxi time at or near IDLE can be included in the warm up period.

ICING, COLD WEATHER AND COLD SOAK CONDITIONS

Do not start the engine until it has been checked that all ice deposits have been removed from the air inlet.

Perform normal engine start. If the engine does not start, maintenance procedures may be required or ground heating may be necessary to warm the nacelle, Air Turbine Starter (ATS) and Starting Control Valve (SCV).

During start with low oil temperatures, the oil pressure may drop below the minimum oil pressure levels temporarily after start. If the oil pressure remains below minimum levels for more than 2 min, the engine must be shut down and the oil heated. In this case, in order to improve the chances of a successful engine start, the oil temperature should be raised to at least -20°C. During the subsequent start after heating the oil, if the oil pressure does not recover, the engine must be shut down and the cause investigated.

User: aherrera - Printed By myTechCare - Aug 09/22 - 14:17:22

CAUTION: • TO PREVENT DAMAGE TO NACELLE COMPONENTS, DO NOT ALLOW THE HOT AIR FROM THE GROUND CART TO EXCEED 93°C (200°F).

- DURING COLD WEATHER OPERATIONS, OIL PRESSURE PEAKS TO FULL SCALE MAY OCCUR DUE TO HIGH OIL VISCOSITY. OIL PRESSURE SHOULD DECREASE AS THE OIL TEMPERATURE INCREASES. IF THE OIL PRESSURE REMAINS ABOVE NORMAL OPERATING RANGE, THE ENGINE SHOULD BE SHUTDOWN AND THE CAUSE INVESTIGATED.

User: aherrera - Printed By myTechCare - Aug 09/22 - 14:17:22

3-10	Page 2	Code 01
------	-----------	------------

ENGINE START - ACTIONS and CALLOUTS		
	LSP	RSP
ENGINE START SEQUENCE	<p>“STARTING ENGINE 1 (2) ”</p> <ul style="list-style-type: none"> • Turn the START/STOP selector to START momentarily and back to RUN, keeping the hand on the START/STOP selector to abort the engine start if necessary. • Start Clock. 	-
	<ul style="list-style-type: none"> • Check N2 rising. 	<ul style="list-style-type: none"> • Check N2 rising.
	<ul style="list-style-type: none"> • Monitor IGN A (B) at 14% N2, fuel flow at approximately 28% N2 or 12 seconds after ignition is activated. 	<ul style="list-style-type: none"> • Start Clock with fuel flow indication and verify ITT rise within 10 seconds.
	<ul style="list-style-type: none"> • Make sure that N2 and N1 accelerate normally and that positive oil pressure is indicated. • Stop clock at 57% N2 (Starter limitation). 	<ul style="list-style-type: none"> • Verify the annunciation IGN A (B) goes out at approximately 57% N2.
	<ul style="list-style-type: none"> • Verify that the engine stabilizes at idle and call out “NORMAL START”. 	-



NOTE: - Airplanes equipped with FADEC earlier than B7.4 during engine start the crew should monitor fuel flow at approximately 31% N2 or after ignition is activated.

User: aherrera - Printed By myTechCare - Aug 09/22 - 14:17:22

3-10	Page 4	Code 01
------	-----------	------------

USE OF APU

EXTEND LIFE OF MAJOR APU COMPONENTS

The life of APU and its components is highly dependent on operating practices. Duty cycle and application and removal of load on APU can significantly impact the life of APU components, specially its turbine wheel.

Hamilton Sundstrand released a Service Information Letter – SIL 352 Rev 2 and on – with suggested guidelines to help improve APU turbine wheel life. The guidelines are:

- Warming-up the APU for 3-5 minutes with generator load only, before applying a pneumatic load.
- Minimize the transition time between a high-load, APU bleed ON, to a no-load, APU bleed OFF during engines starts.
- Shut down the APU while under load (ECS and Generator Load), or within 10 seconds after the load is removed. No cool down required after load is removed.

Even though these guidelines can help operators extend life of major APU components, airlines operational requirements take precedence over APU life extension recommendations.

For more information, please refer to Hamilton Sundstrand SIL 352 and on.

User: aherrera - Printed By myTechCare - Aug 09/22 - 14:17:22

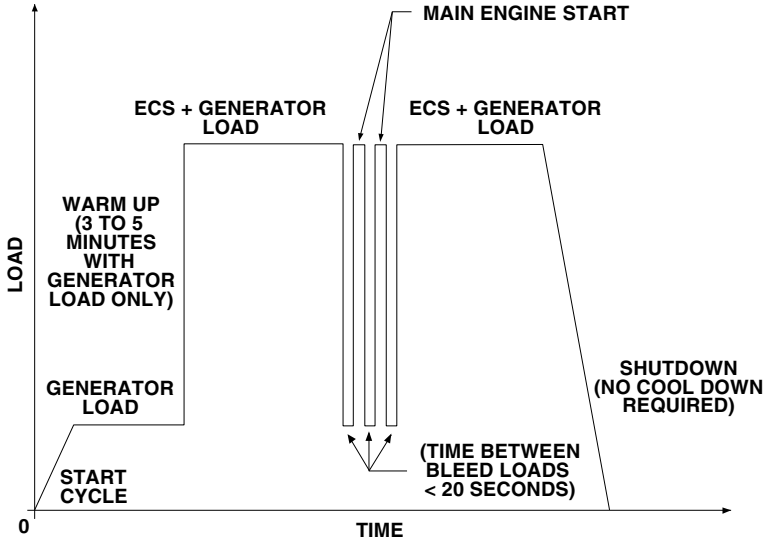

EM145AOM980001A.DGN

APU Cycle Profile For Optimum Turbine Wheel Life

PUSH BACK

Pushback procedure is used to move the airplane from the terminal gate before flight and also to facilitate ground movement on ramps and taxiways. It is recommended to complete the Before Start Checklist prior to start the maneuver. Assure with ground personnel that area is clear.

One towing supervisor is necessary to control the towing operation. The towing supervisor should establish communication with towing personnel and flight crewmembers at all times.

The engines can be started before, during or after the push back maneuver.

Power back is not allowed.

FLIGHT CONTROLS CHECK

Each time electromechanical gust lock lever is set to unlocked (FREE) position elevator movement must be checked. This check must be performed at least 10 seconds after positioning the gust lock lever to the unlocked (FREE) position by moving the control column from the full up stop to the full down stop and back to the full up stop position.

With the airplane taxiing on a straight line or standing still, check the RUDDER by pressing the steering disengage button on the control wheel and moving the pedals from full right to full left, and pressing the steering handle to reconnect the steering.

AFTER START- ACTIONS and CALLOUTS

	LSP	RSP
<p>AFTER ENGINE START IS COMPLETE AND AIRPLANE IS STOPPED</p>	<p>“SET FLAPS ____, FLIGHT CONTROLS CHECK”.</p>	<ul style="list-style-type: none"> • Move flap lever to the desired position and verify EICAS indication. <p>“FLAPS __ SET”.</p>
	<ul style="list-style-type: none"> • Press the STEERING DISENGAGE SWITCH. • Check the flight controls before taxi. ELEVATOR, AILERON and RUDDER should be checked for free travel to their full deflection stops. • Press the steering handle. <p>“AFTER START CHECKLIST”.</p>	<ul style="list-style-type: none"> • Accomplish after start actions. • Perform the rudder check following the LSP movement. • Read the after start check list and calls. <p>“AFTER START CHECKLIST COMPLETED”.</p>
	<ul style="list-style-type: none"> • Verify left side of the airplane. <p>“LEFT SIDE CLEAR”.</p>	<ul style="list-style-type: none"> • Verify right side of the airplane. <p>“RIGHT SIDE CLEAR”.</p>

NOTE: Callouts are shown in bold text.

TAXI

GENERAL

Before the taxi out sequence the flight crew shall have the After Start Checklist completed thoroughly.

Prior to taxi both pilots have to:

- Adjust the seats and rudder pedals;
- Check the actual airplane parking position;
- Verify the airport related charts for possible taxi routes;
- If applicable write and brief the taxi clearance when received.

Turn on the taxi light and after parking brake release check normal brakes.

During taxi:

- Follow the ATC taxi instructions and check the differences from the initial briefing when applicable;
- Use standard phraseology and read back ATC instructions.

Flight crews should minimize “heads-down” activities such as entering data into the FMS while the airplane is moving. Briefing the taxi route will reduce the cockpit workload. ATC should be contacted anytime there is a concern about a potential conflict.

Avoid taxiing closely behind other airplane where FOD may be blown.

TAXI SPEEDS AND BRAKING

Recommended taxi speed:

- Straight / DRY: 30 kt
- Straight / WET or CONTAMINATED: 10 kt
- Turns / DRY: 10 kt
- Turns / WET or CONTAMINATED: 5 kt

The speed could be checked on PFD selecting FMS as the information source.

At idle thrust, the airplane may accelerate to a higher taxi speed than desired.

CARBON BRAKES

The brake assembly on the ERJ family has a carbon brake heat sink. This differs from traditional steel brakes since carbon brake wear is strongly affected by brake temperature. Carbon brakes wear less when operated at high temperatures while steel brakes wear less when operated at low temperatures.

Overnight or long period parking in cold weather:

- Avoid leaving the parking brake set. This will decrease the chances of having brake stacks frozen together in case moisture was present prior brake application.

General rules for carbon brakes:

- During taxi, minimize the duration of each brake application when practical by using shorter applications with higher pressure on the pedals.
- Avoid using brakes asymmetrically.

Number of brake applications:

- Minimize the number of brake applications when practical. The number of brake applications governs carbon brake wear.

Taxi when brakes are cold:

- Do not intentionally use the brakes solely to heat them.
- Carefully manage taxi speed. Let airplane accelerate to a maximum safe speed, then use the brakes in one increasingly firm application to slow the airplane. Then release the brakes and allow the airplane to accelerate again. Less frequent use of brakes with higher braking pressure improves brake life.

Taxi when brakes are warm:

- Carefully manage taxi speed. Let airplane accelerate to a maximum safe speed then use brakes in a short but firm application. This will help keep the brake within operating temperature range limits by allowing more cooling time and less brake friction time.

INFLUENCES ON TIRE WEAR

- Tire inflation: An increase or decrease in pressure from the specified operational value can cause deterioration on the tire, and have the most important effect on the tire life.
- Airport conditions: Pavement surfaces texture significantly contributes to tire wear, which tends to increase when runways, taxi strips, ramps and other paved field areas are in bad condition, strewn with debris, contaminated (with hydraulic fluid, fuel, oil, grease, etc) or poorly maintained. Tires are more susceptible to increase wear in airports where longer taxi distances are required.
- Environmental conditions: Tires are more susceptible to a higher wear rate when the airplane operates in hot temperatures combined with low relative humidity.
- Average takeoff and landing weight: Tires are more susceptible to a higher wear rate when the airplane operates regularly at higher average take-off and landing weight.
- Flight leg time and turn around time (TAT): Lower flight leg time and lower TAT have influence in the tire wear rate. In this scenario the tires work in higher temperatures.
- Temperature between departure and arrival airport: High differences of temperature between departure and arrival airports could also influence in the tire wear when proper inflation adjustment is not observed.

THRUST USE DURING TAXI

Taxi can normally be initiated without increasing thrust at light to medium weights. Increase the thrust smoothly until the airplane starts moving to avoid a setting higher than needed.

Use reverse thrust during taxi only if really necessary.

RUDDER/STEERING USE AND TURNING RADIUS

For straight ahead taxiing or for small changes of direction, the use of rudder pedal steering mode may be used. The maximum steering angle of rudder pedal is +/- 5°.

At speeds between 20 kt and 40 kt use the steering handle only if necessary and exercise care as at these speeds the steering handle is very responsive.

Handwheel steering mode should be used for wider turn angles. To operate in this mode the handle must be kept pressed otherwise the system reverts to rudder pedals. Whenever the handle is pressed, the system reverts back to the handwheel steering. The wheel deflection as function of handle deflection is not linear. For detailed information refer to AOM section 2-12-15.

Let the airplane move a little forward before starting a turn and avoid stopping the airplane in a turn as excessive thrust will be required to start taxiing again. After completing a turn and prior to stopping, center the nosewheel and allow the airplane to roll straight ahead for a short distance.

Nosewheel skidding may occur with:

- Excessive steering angle;
- High taxi speed during turns;
- On wet surfaces during turn.

When taxiing, make turns with the largest feasible turn radius possible. The minimum turn radius should still allow the tire closer to the center of the turn to continue rolling. When making a tight turn, the tires are subject to high lateral loads and can experience damage. Asymmetric thrust may be used in tight turns to minimize side loads on gear and tires.

Minimize thrust assist from outboard engine in 180° turn, particularly if outboard engine overhangs dusty areas next to the taxiway.

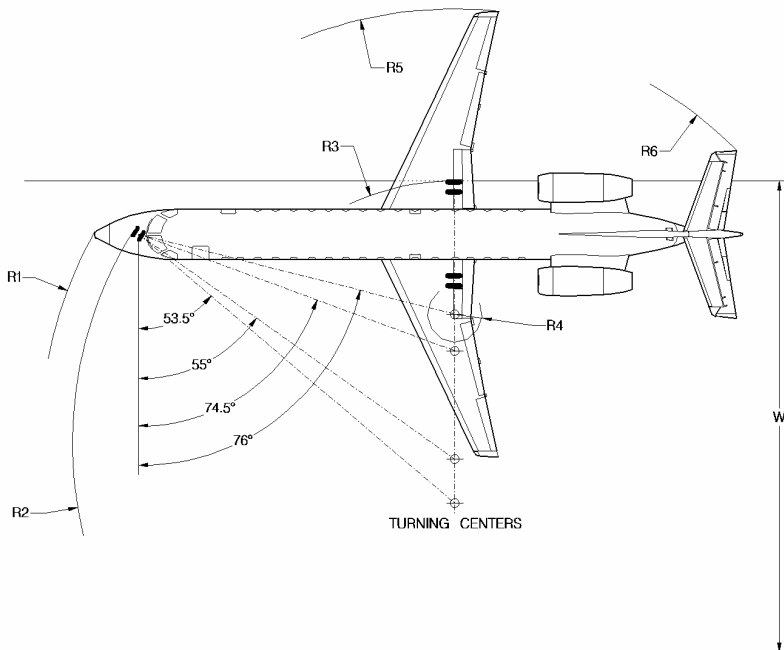

STEERING ANGLE	NOSE GEAR R1	NOSE GEAR R2	OUTBOARD GEAR R3	INBOARD GEAR R4	RIGHT WINGTIP R5	RIGHT TAILTIP R6	WIDTH W
53.5°	19.79 m	18.19 m	13.08 m	8.31 m	20.81 m	19.43 m	31.27 m
	64 ft 11 in	59 ft 8 in	42 ft 3 in	27 ft 3 in	68 ft 3 in	63 ft 9 in	102 ft 6 in
55°	19.48 m	17.86 m	12.50 m	7.74 m	20.24 m	19.00 m	30.36 m
	63 ft 11 in	58 ft 7 in	41 ft 0 in	25 ft 5 in	66 ft 5 in	62 ft 4 in	99 ft 6 in
74.5°	17.10 m	15.21 m	6.39 m	1.62 m	14.17 m	15.12 m	21.94 m
	56 ft 1 in	49 ft 11 in	21 ft 0 in	5 ft 4 in	46 ft 6 in	49 ft 7 in	72 ft 0 in
76°	17.01 m	15.11 m	5.99 m	1.25 m	13.77 m	14.92 m	21.21 m
	55 ft 9 in	49 ft 7 in	19 ft 8 in	4 ft 1 in	45 ft 2 in	48 ft 11 in	69 ft 7 in

145114332.MCE

MINIMUM TURNING RADII FOR EMBRAER 145 MODELS

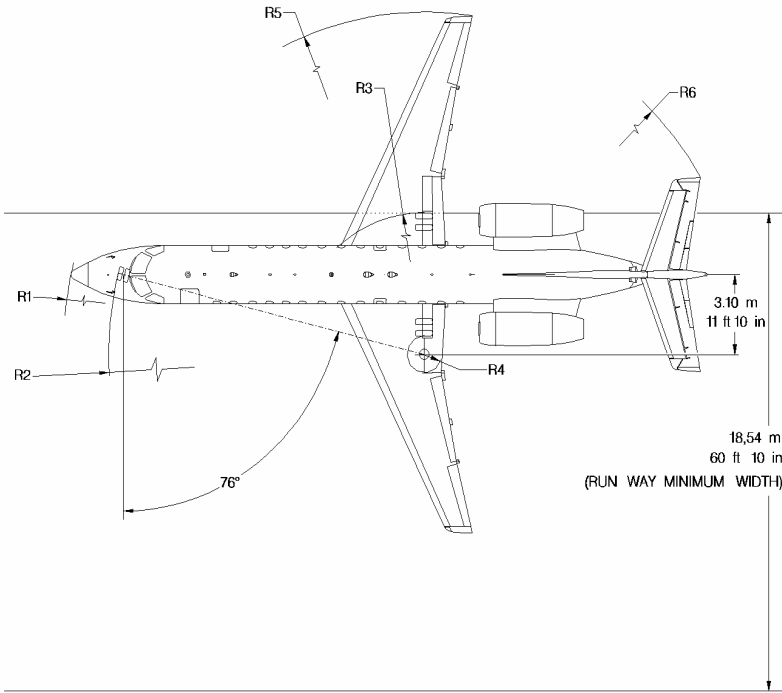

STEERING STEEL	NOSE R1	NOSE GEAR R2	OUTBOARD GEAR R3	INBOARD GEAR R4	RIGHT WINGTIP R5	RIGHT TAILTIP R6
76°	14.94 m	13.05 m	5.49 m	0.72 m	13.27 m	13.34 m
	49 ft 0 in	42 ft 10 in	18 ft 0 in	2 ft 4 in	43 ft 7 in	43 ft 9 in

1451114336.MCE

MINIMUM TURNING RADII FOR EMBRAER 135 MODELS

3-10	Page 14	Code 01
------	------------	------------

Copyright © by Embraer. Refer to cover page for details.

REVISION 4

SOP-145/1489

User: aherrera - Printed By myTechCare - Aug 09/22 - 14:17:22

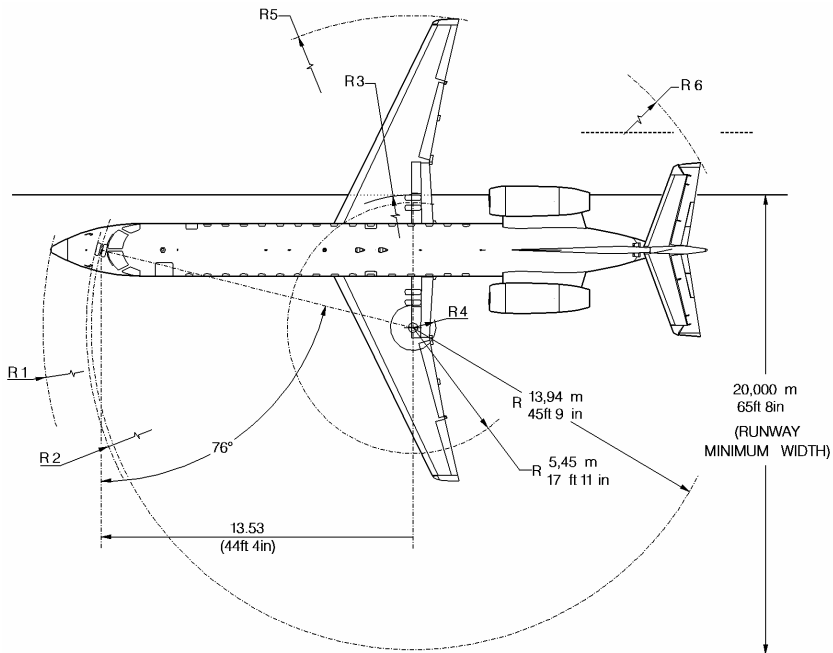

STEERING STEEL	NOSE R1	NOSE GEAR R2	OUTBOARD GEAR R3	INBOARD GEAR R4	RIGHT WINGTIP R5	RIGHT TAILTIP R6
76°	16.05 m	14.16 m	5.74 m	0.98 m	13.53 m	14.40 m
	52 ft 8 in	46 ft 6 in	18 ft 10 in	3 ft 3 in	44 ft 5 in	47 ft 3 in

14SAOM2120021.MCE

MINIMUM TURNING RADII FOR EMBRAER 140 MODELS

SOP-145/1489

REVISION 4

3-10	Page 15	Code 01
------	------------	------------

SINGLE ENGINE TAXI

To improve fuel savings a single engine taxi can be used, delaying the start of the second engine prior to takeoff and/or shutting one engine just after landing when taxiing in.

Single engine taxi may be performed when operating under icing conditions provided that the Engine Run-Up procedure is used before takeoff. However, single engine taxi should be avoided when operating on slippery or contaminated taxiways.

When performing a single engine taxi both Electric Hydraulic Pumps Selector knob must be set to AUTO. Check on MFD Hydraulic Page that both hydraulic systems pressure are within green range.

Consider airplane weight, uphill slopes, time to warm up and cool down the engine and time to the active runway to perform this procedure. Smoothly increase thrust to move the airplane until sufficient forward speed has been attained. If possible, start slight turn in the direction of the non-operating engine. There will be less stress in nose gear structure, otherwise a higher thrust setting will be necessary with the incoming risks of the jet blast and foreign object ingestion in the engine. Consider to evaluate the turns along the taxi route for the election of the engine to be shut down when taxiing.

Maintain constant pressure on the tiller, due to asymmetric thrust during taxi. The appropriate taxi speed depends on the turn radius and surface condition.

SECOND ENGINE START

The engine start should be preferably performed with the airplane static to avoid heads down condition during taxi.

Prior to takeoff, the second engine warm up cycle must be performed by keeping the engine running at or near IDLE for at least 2 minutes before selecting high thrust settings.

TAXI IN

When taxiing in, engines cool down cycle must be performed by keeping the engines running at least 1 minutes after IDLE thrust has been set before engine shutdown to allow engine thermal stabilization.

ENGINE 1 (2) SHUTDOWN

In order to maintain hydraulic pressure on both brake systems the Electric Hydraulic Pump must be kept AUTO throughout the taxi.

TAXI UNDER ADVERSE WEATHER

Taxi on a wet or contaminated surface requires lower speeds. Use the nose wheel steering with caution to avoid skidding during turns.

During cold weather, use minimum thrust for breakaway and taxiing, to avoid blowing snow or slush on personnel or airplanes nearby.

Use firm brake pressure on taxi stops whenever pavement conditions permit in order to warm up the brakes and dry moisture buildup within the disk stack. Anti-skid protection is not provided below 10 kt, so apply brakes accordingly.

On ground, if engine vibration increases, advance thrust levers, one at a time, to obtain at least 60% N1 for 5 seconds and then return to the former setting.

During taxi, "cold set" (the condition where the tire retains the flat shape it had while parked) may induce vibration in the airplane. Vibration should disappear as the tires recover their elasticity during taxi. Turns should be performed at the largest turning radius, preferably at a speed which do not required braking during the turn. Maintain a greater than normal distance behind other airplanes while taxiing in snow or slush-covered runways, to avoid contamination by snow blown by jet blasts.

During low visibility or unfamiliar airport operation observe the ground markings and consider requesting a FOLLOW ME vehicle to proceed taxiing safely.

ENGINE FIRE ON GROUND

When a fire condition is detected by the Engine Fire Detection System, the associated EICAS messages and alarms are generated. Although, the ENGINE 1 (2) FIRE procedure is designed to guide the pilots on the right path to solve this emergency situation in all conditions, it has some peculiarities when this event happens on ground.

ENGINE FIRE ON GROUND PROCEDURE

Reduce thrust levers to idle. Whenever possible, stop the airplane on a position so that the fire is on the downwind of the fuselage. After the complete stop of the airplane, apply parking brakes, alert cabin crew, shutdown the affected engine, pull the associated Fire Extinguisher Handle. If fire persists, accomplish the ENGINE FIRE, SEVERE DAMAGE OR SEPARATION checklist.

User: aherrera - Printed By myTechCare - Aug 09/22 - 14:17:22

3-10	Page 18	Code 01
------	------------	------------

ENGINE FIRE ON GROUND - ACTIONS AND CALLOUTS		
	LSP	RSP
With the airplane static, taxiing in, taxiing out or after a RTO	<ul style="list-style-type: none"> The pilot first noticing the malfunction identifies and announces it. “ENGINE ___ FIRE”. 	
	<ul style="list-style-type: none"> Reduce thrust levers to idle. 	—
With the airplane static or when the airplane has stopped	<ul style="list-style-type: none"> Sets Parking Brake ON. Alerts cabin crew (P.A.): ”ATTENTION CREW, WAIT FOR INSTRUCTIONS”. Sets affected engine START/STOP selector to STOP. 	<ul style="list-style-type: none"> Pulls the associated engine Fire Extinguisher Handle.
If fire persists	“ENGINE FIRE, SEVERE DAMAGE OR SEPARATION CHECKLIST”.	—
If emergency evacuation is required	<ul style="list-style-type: none"> Accomplish Emergency Evacuation Procedure. 	

NOTE: Callouts are shown in bold text.

EMERGENCY EVACUATION

An evacuation can be classified as planned or unplanned. A planned evacuation allows the crew to revise the procedures and to prepare the passengers during flight. An unplanned evacuation occurs suddenly with almost no time for briefing.

In case of a planned evacuation, like in a partial or gear up landing, the planning, communication, speed and the application of the procedures are essential for the success of the operation.

EMERGENCY EVACUATION PROCEDURE

After the complete stop of the airplane, apply parking brakes, depressurize the cabin, set thrust levers to idle, pull the Fire Extinguishing Handles, press the APU Fuel Shutoff Valve, turn off both fuel and hydraulic electric pumps 1 and 2, and discharge the Engines and APU Fire Extinguisher Bottle. At this moment, pilot should verify which side(s) is (are) clear for evacuation, notify the cabin crewmembers, turn on the emergency lights and command the emergency evacuation through the P.A. system. In case the pilot is unable to do so, the command will be given by the next ranking and capable crewmember. After fire extinguishing agent discharge, in case of the fire alarm persistence, the fire should be visually confirmed by the crew or confirmed by requesting ground personnel's help.

Notify the ATC. Before leaving the airplane the pilot must turn off the batteries and from this moment, the alert system, and the P.A. will be off. In case of ditching, after completing the QRH procedures, pilots must dress the lifejackets and should go to the passenger cabin to assure the complete evacuation of the airplane and to supervise the after evacuation tasks. If it is not possible to reach the passenger cabin, both pilots have to evacuate the airplane through the cockpit window.

EMERGENCY EVACUATION – ACTIONS AND CALLOUTS

	LSP	RSP
When airplane has stopped	“EMERGENCY EVACUATION”.	–
	<ul style="list-style-type: none"> • Sets Parking Brake ON. • Sets Thrust Levers to idle. • Alerts cabin crew (P.A.): “ATTENTION CREW, WAIT FOR INSTRUCTIONS”.	<ul style="list-style-type: none"> • Presses the Pressurization DUMP Button. • Fire Extinguishing Handles PULL, APU Shutoff Valve PUSH IN (Extinguishing Bottles if necessary DISCHARGE). • Fuel Pumps Pwr 1 and 2 OFF. • Hyd Elec Pumps 1 and 2 OFF.
	<ul style="list-style-type: none"> • Alerts cabin crew (P.A.): “INITIATE EVACUATION”.	<ul style="list-style-type: none"> • Emergency Lights ON. • Notifies ATC.
	“EMERGENCY EVACUATION CHECKLIST”.	<ul style="list-style-type: none"> • Accomplish checklist. “EMERGENCY EVACUATION CHECKLIST COMPLETED”. <ul style="list-style-type: none"> • Selects Batteries OFF.

NOTE: Callouts are shown in bold text.

The command to initiate evacuation is given by the Captain through the PA system. In case the Captain is unable to do so, the command will be given by the next ranking and capable crewmember.

- Before initiating emergency evacuation, the captain should verify and clearly announce which side(s) is safe for evacuation.
- If it is possible, both pilots should evacuate the airplane through the passenger cabin doors.
- FO evacuates the airplane and assists passengers on the ground.
- Captain should be the last crewmember to leave the airplane, checking that all persons have already been evacuated.
- If it is not possible to reach the passenger cabin, both pilots have to evacuate the airplane through the cockpit windows.

TAKEOFF

GENERAL

Before the takeoff sequence the flight crew shall have the Before Takeoff Checklist completed thoroughly.

Takeoff briefing shall be performed prior to engines start in order to not interfere with takeoff preparation. The briefing shall cover all actions for both normal, such as the applicable takeoff flaps and non-normal takeoff procedures expected to be used during the takeoff phase. Additional briefing items may be required when different elements exist, such as adverse weather, runway in use, runway conditions, noise abatement requirements, dispatch using the Minimum Equipment List (MEL), terrain clearance, special engine failure departure procedure or any other situation or special consideration that differ from routine.

Some types of techniques can be used in the takeoff phase, the types described below are definitions used in the day by day operation.

Normal Takeoff up to 10 kt tailwind: After the airplane is lined up, PF adjusts the Thrust Levers to THRUST SET detent. Equal power settings should be verified before releasing the brakes, especially on slippery runways.

Rolling Takeoff: Pilot lines up the airplane with the centerline and, if cleared for takeoff the PF shall proceed as the Normal Takeoff without braking when lined up.

NOTE: For normal and rolling takeoffs, performance data is valid from the point where takeoff thrust (N1 target) is achieved. During acceleration of the engines from idle to N1 target approximately 20 meters of the available runway will be used.

For a **Static Takeoff:** After the airplane is lined up, move throttles to THRUST SET detent, release brakes only after engines have reached the takeoff thrust (N1 Target).

The LSP is always responsible for aborting the takeoff and will always hold the Thrust Levers from the moment takeoff thrust has been reached until V1 is announced.

In case the RSP is the PF, he/she will remove his/her hand from thrust levers after T/O thrust has been checked.

SOP-145/1489

REVISION 4

3-15-01	Page 1	Code 01
---------	-----------	------------

All abnormalities as foreseen in the SOP Emergency/Abnormal procedures must be called out in a loud and clear voice.

If the LSP decides to abort the T/O he must call out "REJECT" applying Reverse Thrust as required and pushing the yoke forward to prevent the inadvertent rotation; if the LSP decides to continue, he must call out "GO".

During takeoff run, the PF shall use the pedals to steer the airplane. The use of the nose wheel steering handle during the takeoff roll is not recommended once it might lead to airplane overreaction as the groundspeed increases. Flight Director Guidance must be used in all takeoffs except on approved special procedures.

FLAP RETRACTION

Flap retraction should be accomplished after the specified acceleration altitude is reached. The minimum acceleration altitude for Slat/Flap retraction is 400 ft.

3-15-01	Page 2	Code 01
---------	-----------	------------

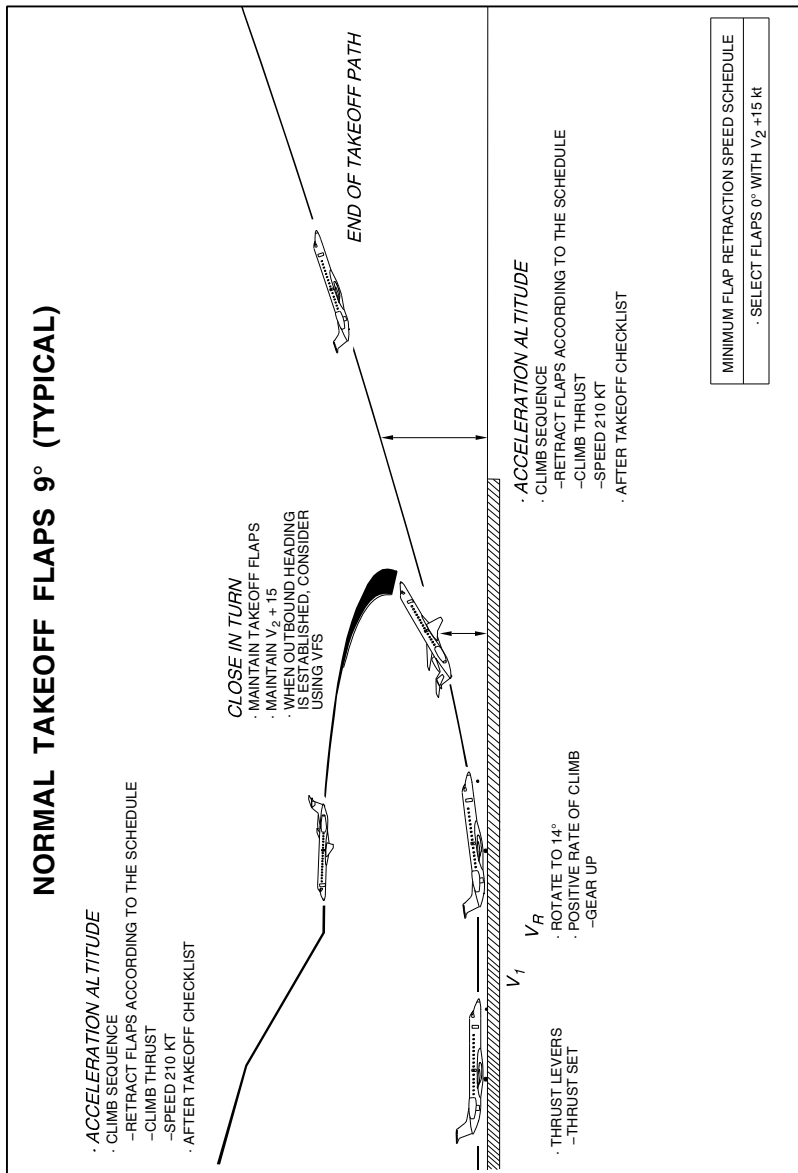

EM145AOM021001D.DGN

NORMAL TAKEOFF FLAPS 18° (TYPICAL)

- ACCELERATION ALTITUDE
- CLIMB SEQUENCE
- RETRACT FLAPS ACCORDING TO THE SCHEDULE
- CLIMB THRUST
- SPEED 210 KT
- AFTER TAKEOFF CHECKLIST

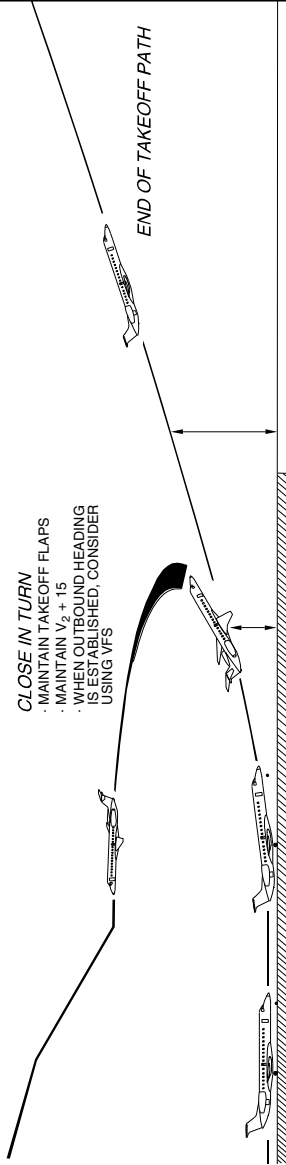

- CLOSE IN TURN**
- MAINTAIN TAKEOFF FLAPS
 - MAINTAIN $V_2 + 15$
 - WHEN OUTBOUND HEADING IS ESTABLISHED, CONSIDER USING VFS

- THRUST LEVERS
- THRUST SET
- V_1
- V_R
- ROTATE TO 13°
- POSITIVE RATE OF CLIMB
- GEAR UP

- ACCELERATION ALTITUDE
- CLIMB SEQUENCE
- RETRACT FLAPS ACCORDING TO THE SCHEDULE
- CLIMB THRUST
- SPEED 210 KT
- AFTER TAKEOFF CHECKLIST

MINIMUM FLAP RETRACTION SPEED SCHEDULE
· SELECT FLAPS 9° WITH $V_2 + 10$ kt
· SELECT FLAPS 0° WITH $V_2 + 30$ kt

EM145AOM000045A.DGN

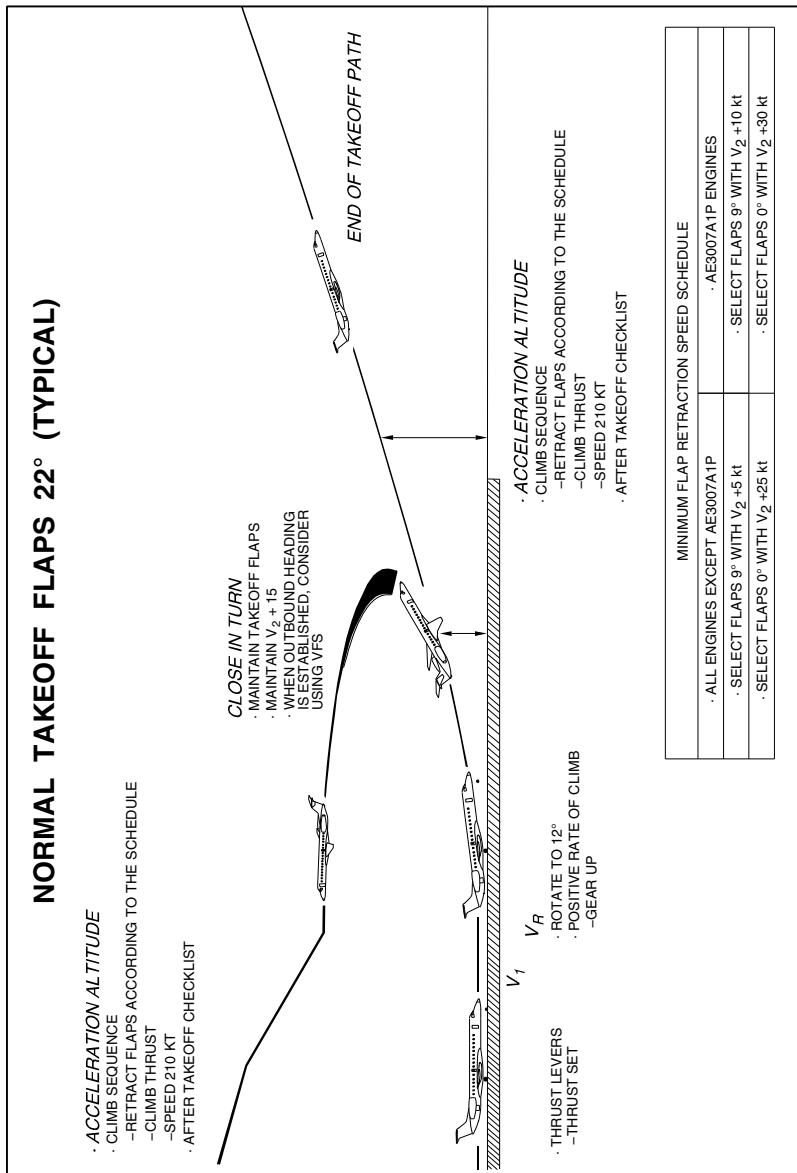

EM145AOM000044A.DGN

TAKEOFF - ACTIONS AND CALLOUTS

TAKEOFF – ACTIONS AND CALLOUTS		
	PF	PM
Airplane lined up on the runway	<ul style="list-style-type: none"> – Advances the Thrust Levers to THRUST SET. <p>“CHECK THRUST”.</p>	<ul style="list-style-type: none"> – Verifies that the N1 reached is the target N1, the engine parameters are normal and that ATTCS (for ALT-TO) is ARMED. <p>“THRUST CHECKED”.</p>
Airplane accelerates past 80 KIAS	“CHECKED”.	“EIGHTY KNOTS”.
Airplane passes V_1 and V_R	<ul style="list-style-type: none"> – Rotates airplane according to the FD pitch indication. 	<p>“V_1”.</p> <p>“ROTATE”.</p>
Positive Rate of Climb	<ul style="list-style-type: none"> – Confirms positive rate of climb. <p>“GEAR UP”.</p>	<ul style="list-style-type: none"> – Verifies positive rate of climb. <p>“POSITIVE RATE”.</p> <ul style="list-style-type: none"> – Positions gear lever up.

NOTE: Callouts are shown in bold text.

CONTINUES ON NEXT PAGE

3-15-01	Page 6	Code 01
---------	-----------	------------

Copyright © by Embraer. Refer to cover page for details.

REVISION 4

SOP-145/1489

CONTINUED FROM PREVIOUS PAGE

TAKEOFF – ACTIONS AND CALLOUTS		
	PF	PM
400 ft AGL	“SELECT HEADING/NAV” .	– Selects Lateral Mode.
Acceleration Altitude	“CLIMB SEQUENCE” .	<p>Normal Takeoff Flaps 9° – Speed check: $V_2 + 15$ – Retracts Flaps to 0°.</p> <p>Normal Takeoff Flaps 18° (if applicable) – Speed check: $V_2 + 10$ – Retracts Flaps to 9°. – Speed check: $V_2 + 30$ – Retracts Flaps to Zero.</p> <p>Normal Takeoff Flaps 22° (if applicable) – Speed check: $V_2 + 5$ – Retracts Flaps to 9°. – Speed check: $V_2 + 25$ – Retracts Flaps to 0°.</p> <p>-----</p> <p>– Selects CLB thrust. – Selects SPD, set 210 kt or FLC on the FGS. – When flaps are zero: “FLAPS ZERO”.</p>

NOTE: Callouts are shown in bold text.

The Climb Sequence is to be performed by the PM when requested by the PF in a continuous manner and ends when the flaps reach 0 position.

The Climb sequence comprises:

- PM retracting the flaps on schedule, CLIMB Thrust and speed 210 kt or FLC on the FGS.

AFTER TAKEOFF - ACTIONS AND CALLOUTS

AFTER TAKEOFF – ACTIONS AND CALLOUTS		
	PF	PM
UPON FLAP RETRACTION	<p>“AFTER TAKEOFF CHECK LIST”.</p>	<p>- Performs the after takeoff checklist and calls out.</p> <p>“AFTER TAKEOFF CHECK LIST COMPLETED”.</p>

NOTE: Callouts are shown in bold text.

The After Takeoff Checklist should be read in silence by the PM.

Upon completing the After Takeoff Checklist the PM must call out:

“AFTER TAKEOFF CHECKLIST COMPLETED”.

REJECTED TAKEOFF - RTO

During the takeoff phase, a RTO procedure should be initiated, prior to V1, if any adverse or abnormal event occurs that could affect the safety of flight. Many faults can cause a decision to reject, like engine fire, engine failure and some other system faults or events. As adequate decision to reject is taken, the RTO should never be delayed, due to the risk of a runway overrun, because it takes a few seconds for the engines to spool down to idle thrust.

A successful RTO depends on:

- Accurate alert and monitoring during all takeoff phase;
- Captains timely decision;
- All callouts made on a loud, clear and precise communication way;
- Adequate briefing, procedures and coordination.

RESPONSIBILITY

Whoever first identifies the undesirable event or malfunction must announce it, but the decision to perform a RTO is the captain's responsibility. The RTO must be immediately initiated.

ACTIONS

- Actions are to be taken considering that, during all takeoff procedures, the LSP should keep his hand on the thrust levers until V1 has been reached;
- Once the RTO decision has been made, the first action is to set thrust levers idle and apply maximum brakes and reverse thrust (if available) as required;
- Directional control must be kept by applying rudder pedal steering;
- Monitor airplane deceleration, cancel any aural warnings upon malfunction identification, verify reverse thrust status and advise ATC;

- At 60 kt or below, thrust lever (s) can be smoothly returned to minimum reverse, then to idle at 30 kt, or kept on reverse until airplane comes to a complete stop, considering airplane speed, runway length available, slippery surfaces with ice, snow etc;
- As airplane stops, set parking brake ON if the procedures are to be carried out on the runway;
- The airplane should remain on the runway until it is absolutely clear that an emergency evacuation is not necessary and the whole scenario analyzed. If necessary, external aids should be requested or the runway vacated to a safe position according to ATC instructions.

LOW AND HIGH ENERGY SPEEDS

- The sooner an RTO decision is taken, the greater is the chance to safely stop within runway limits. RTO above V_1 may lead to a runway overrun and is the main cause of overrun accidents;
- Low energy speed is considered up to, approximately, 80 kt;
- During takeoff, the 80 kt callout has three main purposes: pilot incapacitation check, airspeed crosscheck and the transition from Low to High Energy speed;
- For High energy speeds only reject the takeoff if there is a malfunction that severely affects the flight safety;
- Upon reaching V_1 and if no decision has been taken, continue the takeoff since there is no assurance that the airplane is capable to stop within the remaining runway length;
- If RTO decision was taken due to fire, take into consideration to position the airplane so that fire is on the downwind of fuselage.

REJECTED TAKEOFF – ACTIONS AND CALLOUTS

	LSP	RSP
If decision was REJECT	<p align="center">–The pilot first noticing the malfunction identifies and announces it.</p> <p>“REJECT”</p> <ul style="list-style-type: none"> –Reduces thrust levers to idle, apply reverse as required. –Applies maximum braking. –Uses reverse as necessary, and –Smoothly returns thrust levers to idle. 	<ul style="list-style-type: none"> – Monitors airplane deceleration. – Verifies the reverse status. – Cancels any aural warnings. – Calls out “SIXTY KNOTS”. – Advises ATC stating the abort.
When airplane has stopped	<ul style="list-style-type: none"> – Sets parking brake ON. – Alerts cabin crew (P.A.): <p>“ATTENTION CREW, WAIT FOR INSTRUCTIONS”.</p> <ul style="list-style-type: none"> – Requests appropriate checklist if applicable. 	<ul style="list-style-type: none"> – Performs appropriate checklist.
If emergency evacuation is required	<ul style="list-style-type: none"> – Comply with Emergency Evacuation Procedures. 	

CROSSWIND TAKEOFF

There is no special related procedure, just maintain directional control using positive rudder and small control wheel inputs.

Runway alignment and smooth symmetrical thrust application are quite important, especially when operating at contaminated runways.

Command control wheel into the wind to maintain wings level throughout the takeoff roll. This control wheel input will decrease as speed increases.

TAIL WIND TAKEOFF

The tailwind takeoff technique is basically the same as for any other takeoff. Use normal rotation rate and target pitch to avoid fuselage body contact with the runway and consider the use of full takeoff thrust.

Special attention should be given if tailwind component increases during liftoff.

TAIL STRIKE CONSIDERATIONS

Although tail strikes are more common during landing phase of flight, it may also occur during takeoff and may cause extensive structural damage. The major causes identified of a tail strike during takeoffs are:

- **Improper Stabilizer Trim**

A mistrimmed stabilizer may be a result of an erroneous input data, like loading weights for load sheet calculation or even an incorrect stab trim setting. In any case, the stabilizer could be wrongly set to nose up which may induce the airplane attempting to fly before V_1 .

- **Improper Rotation Speed**

Wrong speed computations or early rotation could result in nose up without wing lift enough to fly exposing the airplane to a tail strike.

- **Excessive Rotation Rate**

Initiate rotation at V_R at approximately $3^\circ/\text{sec}$, smoothly, towards the flight director angle. Rotation at a pitch higher than normal and inappropriate flight director use during rotation increase the risk of tail strike.

NOISE ABATEMENT PROCEDURES

Noise abatement procedures minimize the overall exposure to noise on the ground and at the same time maintain the required levels of flight safety. There are several methods, including preferential runways and routes, as well as noise abatement procedures for take-off, approach and landing. The appropriateness of any of the procedures depends on the physical layout of the airport and its surroundings, but in all cases it must be given all priority to safety considerations.

Pilots are required to adhere to the noise abatement procedures published specifically for each airport. There are different procedures for noise abatement, and the items listed below are just a guide to help pilots to perform a takeoff with noise reduction:

- Set speed required for the procedure on SPEED Selector Knob.
- At required noise abatement altitude the PF asks for the climb sequence.
- If an engine failure occurs, the noise abatement procedure should be terminated. In this case an engine failure procedure and profile should be performed.

If an engine failure occurs, the noise abatement procedure should be terminated. In this case an engine failure procedure and profile should be performed.

NOTE: Some charts make reference to ICAO A or ICAO B procedures which are similar to NADP 1 and NADP 2 respectively.

The main difference between ICAO A and ICAO B is the location of the noise relief area. The difference is the same between NADP 1 and NADP 2. ICAO A and NADP 1 are procedures to protect areas located close to the airport. ICAO B and NADP 2 are procedures to protect areas located distant from the airport.

NADP 1 / ICAO A procedure

- Climb at $V_2 + 10$ until 800 ft (NADP 1) or 1500 ft (ICAO A) AFE.
- At or above 800 ft (NADP 1) or 1500 ft (ICAO A) AFE select CLB THRUST and verify climb thrust is set, then continue climb at $V_2 + 10$ until 3000 ft AFE.
- At 3000 ft AFE, set VFS, accelerate and retract FLAP on schedule.

User: aherrera - Printed By myTechCare - Aug 09/22 - 14:17:22

3-15-05	Page 6	Code 01
---------	-----------	------------

NOISE ABATEMENT TAKEOFF "A"

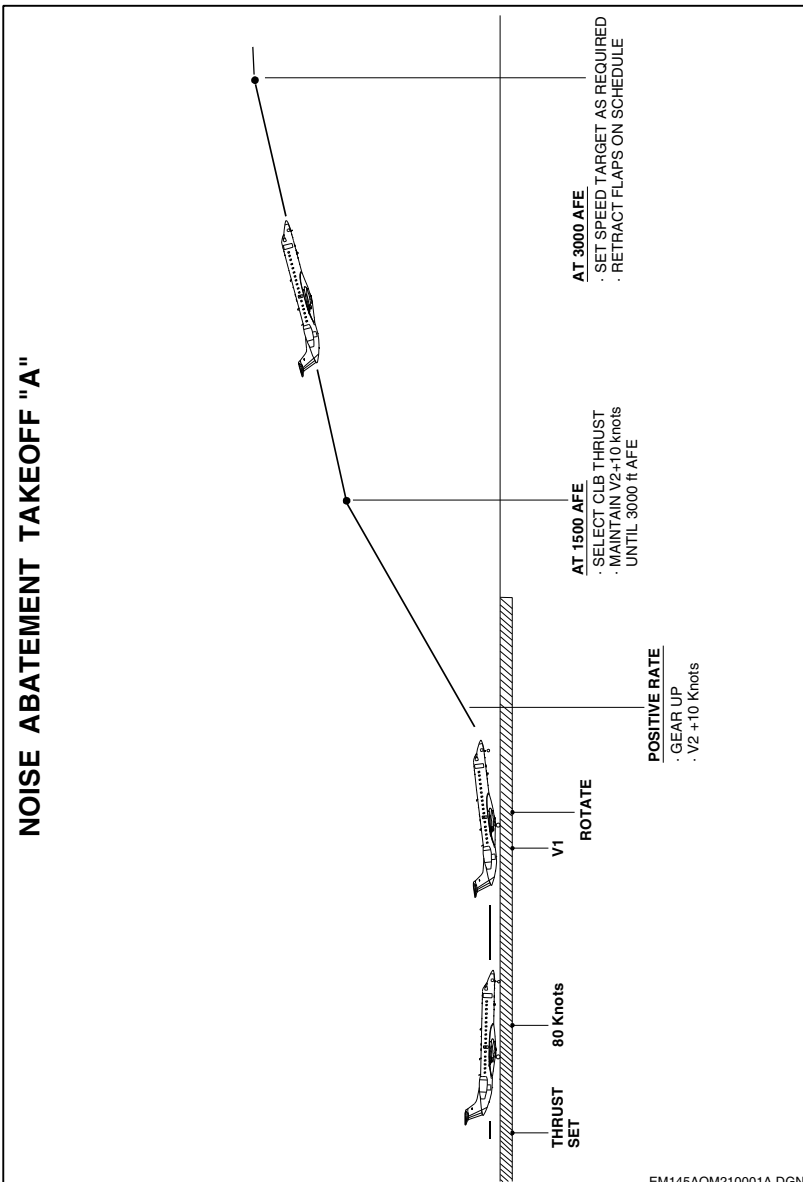

EM145AOM210001A.DGN

User: aherrera - Printed By myTechCare - Aug 09/22 - 14:17:22

SOP-145/1489

REVISION 4

3-15-05	Page 7	Code 01
---------	-----------	------------

NADP 2 / ICAO B procedure

- Climb at $V_2 + 10$ kt until 800 ft (NADP 2) or 1000 ft (ICAO B) AFE.
- At or above 800 ft (NADP 2) or 1000 ft (ICAO B) AFE, select CLB THRUST, verify climb thrust is set, retract FLAP on schedule and maintain $V_{FS} + 10$ until 3000 ft.
- At 3000 ft AFE, set speed target as required and accelerate to the en route climb speed.

NOTE: Operators can use other Noise Abatement Procedures (different from NADP 1/ICAO A or NADP 2/ICAO B) if authorized by local authorities.

3-15-05	Page 8	Code 01
---------	-----------	------------

User: aherrera - Printed By myTechCare - Aug 09/22 - 14:17:22

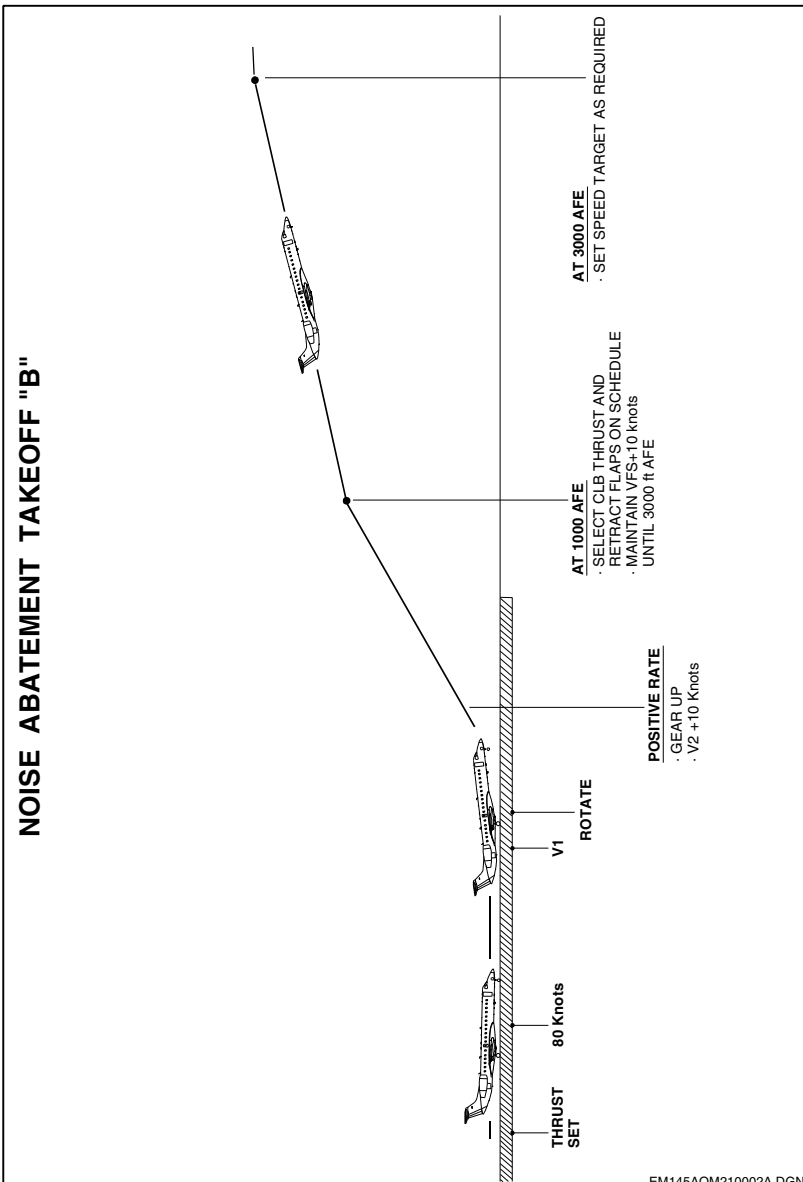

SOP-145/1489

REVISION 4

3-15-05	Page 9	Code 01
---------	-----------	------------

TAKEOFF IN ADVERSE CONDITIONS

For snow pellets, snow grains, ice pellets, moderate and heavy freezing rain and hail the anti-ice fluids have little or no effect. If these conditions exist, perform a careful pre-takeoff check shortly before takeoff.

Prior to takeoff in icing conditions, if engine vibration increases, advance thrust levers, one at a time, to obtain at least 60% N1 for 5 seconds and then return to the former setting.

WINDSHEAR

The policy is always to avoid potential windshear areas. Takeoff briefing can include recent weather reports, visual observations and crew experience with the airport prevailing weather. Consider to delay the takeoff until conditions improve.

Whenever a windshear is suspected during takeoff the following precautions should be taken:

- Use maximum takeoff thrust instead of reduced thrust;
- Increase airspeed (or V_2) to get the best performance compromise during windshear;
- Use the longest runway available with the lowest possibility of a windshear encounter;
- Turn ON the radar using to enable it before initiating the takeoff run;
- Crew should monitor airspeed trend during takeoff run. In case of any evidence of windshear before V_1 , evaluate the possibility to reject takeoff;
- Develop an awareness of normal airspeed, attitude and vertical speed. The crew should closely monitor the vertical flight path instruments, such as, vertical speed and altimeters, and call out any deviations.

3-15-05	Page 10	Code 01
---------	------------	------------

- NOTE:** - If a windshear encounter happens at speeds close to V_1 , the remaining runway may not be sufficient to stop the airplane after an RTO. A high tailwind component may increase the ground speed and so the runway distance required to stop the airplane.
- If the crew assesses that there is no sufficient runway remaining to stop the airplane, advance thrust levers to MAX and rotate the airplane normally at V_R . Once airborne perform the windshear escape maneuver.

For Windshear actions and callouts, refer to the section 3-40.

User: aherrera - Printed By myTechCare - Aug 09/22 - 14:17:22

INTENTIONALLY BLANK

User: aherrera - Printed By myTechCare - Aug 09/22 - 14:17:22

3-15-05	Page 12	Code 01
---------	------------	------------

Copyright © by Embraer. Refer to cover page for details.

REVISION 4

SOP-145/1489

ENGINE FAILURE

RECOGNITION

The first principles to best manage an engine malfunction are to identify the affected engine correctly and take the correct action, considering airplane on ground or in flight.

There are several ways to recognize engine failures, including messages and airplane reactions:

- Airplane heading change (*differential "moment force"*);
- Engine Failure – loss of thrust, ENGINE 1(2) LOW N1 EICAS indication;
- Engine seize – EICAS N1 indicates 0;
- Engine separation – EICAS indicates amber dashes, thrust rating mode will disappear;
- Engine Fire – on ENGINE 1(2) FIRE EICAS indication and Fire Handle illuminates.

ON GROUND

Engine Failure below V_1

If an engine failure occurs prior to V_1 a reject takeoff procedure (RTO) has to be accomplished. (Refer to RTO Procedures).

Engine Failure above V_1

If an engine failure occurs above V_1 , airplane direction and thrust levers must be controlled, aiming to keep airplane on runway centerline by smoothly applying rudder.

As soon as an Engine Failure or FIRE is recognized (not always accompanied by loss of thrust) and the affected engine is identified, check maximum thrust on EICAS.

IN FLIGHT

Rotation must be done to achieve the appropriate pitch following the Flight Director, set aileron in neutral and use rudder and yaw trim to keep wings level. As a reference, the slip / skid indicator shall be approximately $\frac{1}{2}$ to $\frac{1}{4}$ off center and between 0° to 5° of bank, according to speed, gross weight and altitude.

REVISION 4

3-15-10	Page 1	Code 01
---------	-----------	------------

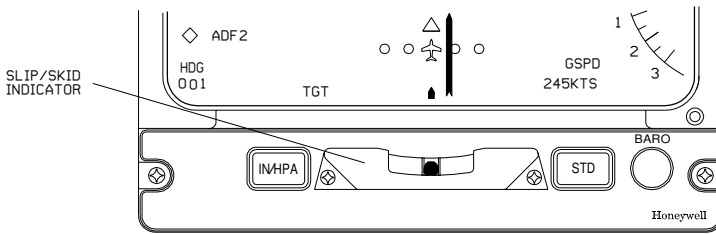

EM145AOM170011A.DGN

Generally the control wheel in the neutral position is a good indication of the lowest drag for single engine.

Crew must keep close attention at first positive rate of climb to retract landing gear, monitoring airplane profile.

Crew must follow the flight director guidance to maintain V_2 up to acceleration altitude.

Takeoff thrust is limited to 5 minutes after takeoff, and it's recommended that emergency procedures be accomplished as soon as safe altitude has been attained (at least 400 ft AGL or according to local minimums).

When engine failure occurs after takeoff, noise abatement procedures no longer apply.

On departure procedures with acceleration altitudes at or above 1000 ft, during takeoff briefing, emphasize that, in the event of an Engine Failure, Engine Fire (with loss of thrust) or any other malfunction requiring a memory item, actions can be commanded at an altitude lower than the acceleration altitude, but not lower than 400 ft. Airplane must be stabilized and on the profile.

Upon crossing the briefed altitude, with the airplane stabilized and on the proper flight path, the PF commands to initiate the memory items.

- NOTE:** - If manually flying the airplane, IAS mode may be used;
 - Flight Director Mode selection should be done by the PM upon PF requests.

For One Engine Inoperative, limit the bank angle to:

15° at V₂

25° at V₂ + 10

FLAP RETRACTION

Use flaps retraction schedule:

Normal Takeoff Flaps 9°:

Flaps 9° to 0° V₂ + 15

Normal Takeoff Flaps 18° (If applicable):

Flaps 18° to 9° V₂ + 10

Flaps 9° to 0° V₂ + 30

Normal Takeoff Flaps 22° (If applicable):

Flaps 22° to 9° V₂ + 5

Flaps 9° to 0° V₂ + 25

User: aherrera - Printed By myTechCare - Aug 09/22 - 14:17:22

ENGINE FAILURE AT OR ABOVE V_1 ACTIONS AND CALLOUTS

ENGINE FAILURE AT OR ABOVE V_1 – ACTIONS AND CALLOUTS		
	PF	PM
Before V_R	<p>“ENGINE ___ FAILURE”. (pilot first noticing the engine failure)</p>	
	<ul style="list-style-type: none"> Controls airplane using rudder. <p>“CHECK THRUST”.</p>	<ul style="list-style-type: none"> Cancel aural warnings. Verifies maximum thrust on operating engine. <p>“THRUST CHECKED”.</p>
At V_R	<ul style="list-style-type: none"> Rotates to appropriate pitch following the Flight Director. 	<p>“ROTATE”.</p>
After lift-off	<ul style="list-style-type: none"> Confirms positive rate of climb. <p>“GEAR UP”.</p>	<ul style="list-style-type: none"> Verifies positive rate of climb. <p>“POSITIVE RATE”.</p> <ul style="list-style-type: none"> Positions gear lever UP.
	<ul style="list-style-type: none"> Climbs at V_2. Controls the airplane using elevator to maintain V_2 besides rudder and yaw trim in the amount necessary to keep the aileron control in neutral position. 	<ul style="list-style-type: none"> Monitors speed and attitude.

NOTE: Callouts are shown in bold text.

CONTINUES ON NEXT PAGE

3-15-10	Page 4	Code 01
---------	-----------	------------

REVISION 4

CONTINUED FROM PREVIOUS PAGE

ENGINE FAILURE AT OR ABOVE V₁ – ACTIONS AND CALLOUTS		
	PF	PM
At 400 ft	<p>“SELECT HEADING, BANK”.</p>	<ul style="list-style-type: none"> • Selects HDG and BNK.
At Acceleration Altitude	<p>“SELECT ALTITUDE HOLD”.</p> <p>“ENGAGE AUTOPILOT”.</p> <ul style="list-style-type: none"> • At flaps retraction speed: “FLAPS ___” <p>“SPD AND CONTINUOUS THRUST”.</p>	<ul style="list-style-type: none"> • Selects Altitude Hold. • Engages AP. ⁽¹⁾ • Retracts flaps on schedule upon PF’s command until flaps zero then calls. “FLAPS ZERO”. • Reaching V_{FS}: “V_{FS}”. • Select SPD on FGC Panel and CON on Thrust Rating Panel.

⁽¹⁾ For autopilot minimum engagement height, refer to AFM Section 2 - Limitations.

CONTINUES ON NEXT PAGE

CONTINUED FROM PREVIOUS PAGE

ENGINE FAILURE AT OR ABOVE V₁ – ACTIONS AND CALLOUTS		
	PF	PM
Climbing to Safe Altitude	<ul style="list-style-type: none"> • Climbs at V_{FS} to a safe altitude defined on the takeoff briefing or as assigned by ATC. • Fly runway heading or comply with One Engine SID or maintain the take off path defined on the takeoff briefing. <p>“(APPLICABLE ABNORMAL) CHECK LIST”.</p>	<ul style="list-style-type: none"> • Advise ATC. • Monitor thrust, attitude and speed.

CONTINUES ON NEXT PAGE

3-15-10	Page 6	Code 01
---------	-----------	------------

CONTINUED FROM PREVIOUS PAGE

ENGINE FAILURE AT OR ABOVE V₁ – ACTIONS AND CALLOUTS		
	PF	PM
<p>Performing Engine Failure Checklist or Memory Items</p>	<ul style="list-style-type: none"> • Places his (her) hand on failed engine Thrust Lever: “THRUST LEVER 1(2) IDLE, CONFIRM?” • Reduces affected engine thrust lever to idle. “1(2) IDLE”. • Confirms the failed engine START/STOP selector: “CONFIRMED” • Takes the ATC communications. 	<ul style="list-style-type: none"> • Reads the checklist aloud: “THRUST LEVER 1(2) IDLE”. • Confirms that the failed engine is being reduced. “CONFIRMED”. “START/STOP 1(2), STOP CONFIRM?”. • Places his (her) hand over the failed engine START/STOP Selector. • Selects the START/STOP Selector to STOP. • Completes applicable Checklist. “(APPLICABLE ABNORMAL) CHECKLIST COMPLETED”.

CONTINUES ON NEXT PAGE

SOP-145/1489

REVISION 5

3-15-10	Page 7	Code 01
---------	-----------	------------

CONTINUED FROM PREVIOUS PAGE

ENGINE FAILURE AT OR ABOVE V₁ – ACTIONS AND CALLOUTS		
	PF	PM
When Engine Failure Checklist is completed	<p>“AFTER TAKE OFF CHECKLIST”.</p>	<ul style="list-style-type: none"> Accomplishes the procedures and checklist. <p>“AFTER TAKEOFF CHECKLIST COMPLETED”.</p>

User: aherrera - Printed By myTechCare - Aug 09/22 - 14:17:22

User: aherrera - Printed By myTechCare - Aug 09/22 - 14:17:22

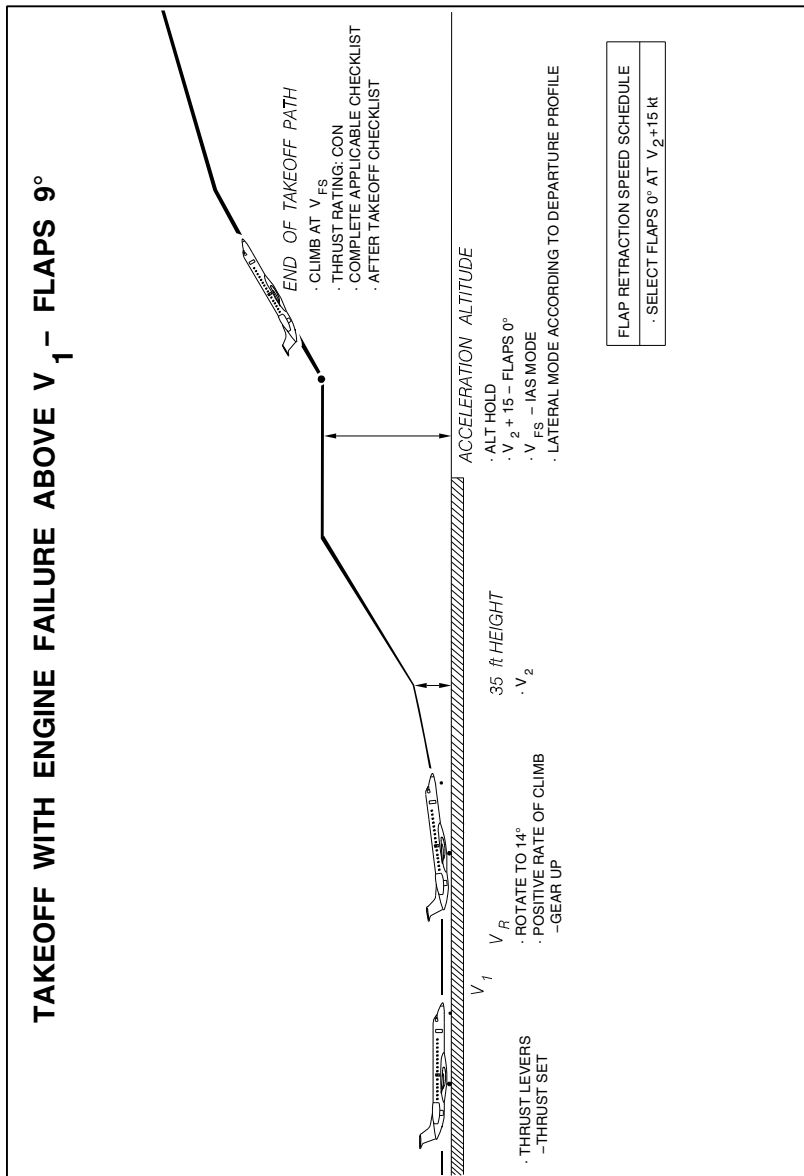

EM145AOM021019B.DGN

SOP-145/1489

REVISION 4

3-15-10	Page 9	Code 01
----------------	------------------	-------------------

TAKEOFF WITH ENGINE FAILURE ABOVE V₁ – FLAPS 18°

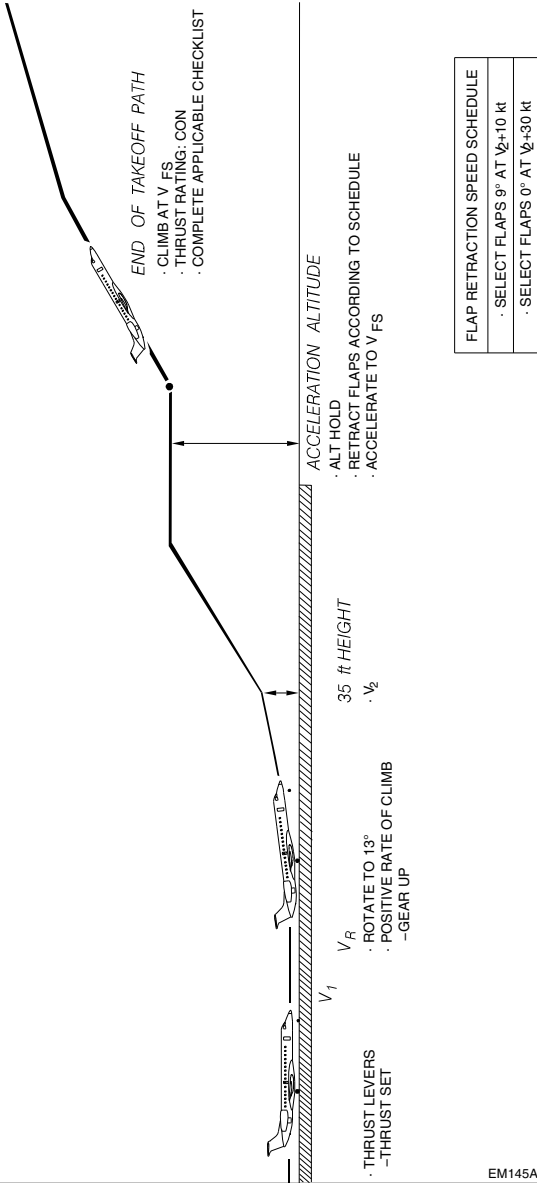

FLAP RETRACTION SPEED SCHEDULE	
·	SELECT FLAPS 9° AT V ₂ +10 kt
·	SELECT FLAPS 0° AT V ₂ +30 kt

EM145AOM020144A.DGN

User: aherrera - Printed By myTechCare - Aug 09/22 - 14:17:22

3-15-10	Page 10	Code 01
---------	------------	------------

Copyright © by Embraer. Refer to cover page for details.

REVISION 4

SOP-145/1489

TAKEOFF WITH ENGINE FAILURE ABOVE V1 – FLAPS 22°

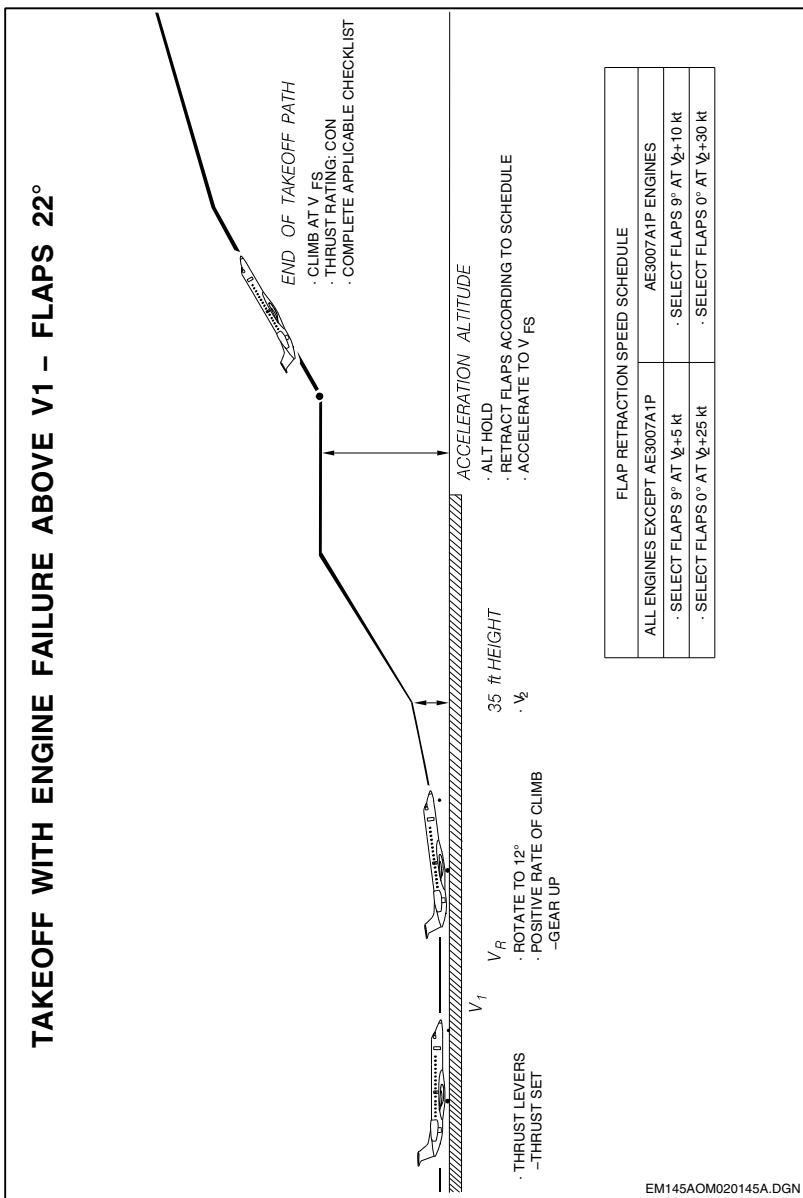

ENGINE FIRE, SEVERE DAMAGE OR SEPARATION (ON TAKEOFF AFTER V₁) ACTIONS AND CALLOUTS

Engine power loss may not occur as a result of Engine Fire. In this case a climb sequence should be performed.

ENGINE FIRE, SEVERE DAMAGE OR SEPARATION (ON TAKEOFF AFTER V₁) – ACTIONS AND CALLOUTS		
	PF	PM
Before V _R	“ENGINE ___ FIRE” . (pilot first noticing the engine failure).	
	<ul style="list-style-type: none"> Controls airplane using rudder. “CHECK THRUST” .	<ul style="list-style-type: none"> Cancels aural warnings. Verifies maximum thrust on operating engine. “THRUST CHECKED” .
At V _R	<ul style="list-style-type: none"> Rotates to appropriate pitch following the Flight Director. 	“ROTATE” .
After lift-off	<ul style="list-style-type: none"> Confirms positive rate of climb. “GEAR UP” .	<ul style="list-style-type: none"> Verifies positive rate of climb. “POSITIVE RATE” . <ul style="list-style-type: none"> Positions gear lever UP.
	<ul style="list-style-type: none"> Climbs at V₂. Controls the airplane using elevator to maintain V₂ besides rudder and yaw trim in the amount necessary to keep the aileron control in neutral position. 	<ul style="list-style-type: none"> Monitors speed and attitude.

CONTINUES ON NEXT PAGE

3-15-10	Page 12	Code 01
---------	------------	------------

REVISION 4

User: aherrera - Printed By myTechCare - Aug 09/22 - 14:17:22

CONTINUED FROM PREVIOUS PAGE

ENGINE FIRE, SEVERE DAMAGE OR SEPARATION (ON TAKEOFF AFTER V₁) – ACTIONS AND CALLOUTS		
	PF	PM
At 400 ft	<p>“SELECT HEADING, BANK”.</p>	<ul style="list-style-type: none"> • Selects HDG and BNK.
At Acceleration Altitude	<p>“SELECT ALTITUDE HOLD”.</p> <p>“ENGAGE AUTOPILOT”.</p> <ul style="list-style-type: none"> • At flap retraction speed: “FLAPS ___”. <p>“SPD AND CONTINUOUS THRUST”.</p> <p>“MEMORY ITEMS”.</p>	<ul style="list-style-type: none"> • Selects Altitude Hold. • Engages AP ⁽¹⁾. • Retracts flaps on schedule upon PF’s command until flaps zero then calls. “FLAPS ZERO”. • Reaching V_{FS}: “V_{FS}”. • Selects SPD on FGC Panel and CON on Thrust Rating Panel.

⁽¹⁾ For autopilot minimum engagement height, refer to AFM Section 2 - Limitations.

NOTE: Callouts are shown in bold text

CONTINUES ON NEXT PAGE

CONTINUED FROM PREVIOUS PAGE

ENGINE FIRE, SEVERE DAMAGE OR SEPARATION (ON TAKEOFF AFTER V₁) – ACTIONS AND CALLOUTS		
	PF	PM
Climbing to Safe Altitude	<ul style="list-style-type: none"> • Climbs at V_{FS} to a safe altitude defined on the take off briefing or as assigned by ATC. • Fly runway heading or comply with airport “One Eng SID” or maintain the take off path defined on the take off briefing. <p>“(APPLICABLE ABNORMAL) CHECKLIST”.</p>	<ul style="list-style-type: none"> • Advise ATC. • Monitor thrust, attitude and speed.

CONTINUES ON NEXT PAGE

CONTINUED FROM PREVIOUS PAGE

ENGINE FIRE, SEVERE DAMAGE OR SEPARATION (ON TAKEOFF AFTER V₁) – ACTIONS AND CALLOUTS		
	PF	PM
<p>Engine Fire, Severe Damage or Separation Checklist</p>	<ul style="list-style-type: none"> • “THRUST LEVER 1(2) IDLE, CONFIRM?”. • Reduces affected engine thrust lever to idle. “1(2) IDLE”. • Confirms the failed engine START/STOP selector: “CONFIRMED” • Confirms his (her) hand on the affected engine Fire Extinguisher Handle. “CONFIRMED” 	<ul style="list-style-type: none"> • Confirms that the failed engine is being reduced. “CONFIRMED”. “START/STOP 1(2) STOP CONFIRM?” • Place his (her) hand over the affected engine Start/Stop SELECTOR. • Selects the affected engine Start/Stop selector to STOP. “FIRE EXTINGUISHER HANDLE 1(2) PULL CONFIRM?” • Place hand on the affected engine Fire Extinguisher Handle and wait PF confirmation.

CONTINUES ON NEXT PAGE

SOP-145/1489

REVISION 5

3-15-10	Page 15	Code 01
---------	------------	------------

CONTINUED FROM PREVIOUS PAGE

ENGINE FIRE, SEVERE DAMAGE OR SEPARATION (ON TAKEOFF AFTER V₁) – ACTIONS AND CALLOUTS		
	PF	PM
<p>Engine Fire, Severe Damage or Separation Checklist</p>	<p>“ENGINE FIRE, SEVERE DAMAGE OR SEPARATION CHECKLIST”.</p> <ul style="list-style-type: none"> • Takes the ATC communications. 	<ul style="list-style-type: none"> • Pulls the affected engine Fire Extinguisher Handle. • Completes the Checklist. <p>“ENGINE FIRE, SEVERE DAMAGE OR SEPARATION CHECKLIST COMPLETED”.</p>
<p>When Engine Fire, Severe Damage or Separation Checklist completed</p>	<p>“AFTER TAKE OFF CHECKLIST”.</p>	<ul style="list-style-type: none"> • Accomplish the procedures and checklist. <p>“AFTER TAKEOFF CHECKLIST COMPLETED”.</p>

CLIMB

GENERAL

The climb phase has a significant impact in fuel consumption when considering short and medium range flights since it represents from 20% to 40% of the trip time, registering fuel flows 40% greater than on cruise phase.

When considering trip fuel, the climb phase shall not be analyzed separately. The impact over the total trip fuel is the best way to check a climb schedule.

EMBRAER provides information in the AOM Flight Planning section for Maximum Climb Angle, Maximum Rate of Climb and recommended Standard Speed Schedule.

The climb-to-cruise altitude should preferably be done by using the AP FLC mode. However, if the flight is short and the cruise altitude is low (25000 ft or less), or if the aircraft is heavy (weight above 20000 kg or 44000 lb), proceed as follows:

- Climb up to 10000 ft using the FLC mode; then select 260 KIAS until the airplane achieves M=0.60; then press the SPD selector knob so that the autopilot maintains a constant Mach number until reaching the cruise level.
- The cabin differential pressure may reach its maximum on prolonged climbs to FL 270 or higher, and this may result in high cabin rates with the consequent passenger discomfort. To avoid this, the following technique can be used:
 - When the cabin differential pressure reaches 8.1 psi on the EICAS, select the autopilot VS mode and use a rate of climb of 1500 ft or less until reaching cruise level.
- If, during a climb, the Air Traffic Control stops the climb momentarily, maintain a speed of 240 KIAS maximum if at FL 100 or lower and 300 KIAS if above FL 100. To restart the climb, reselect the new target altitude with the ASEL button and use the VS mode with a rate of 2000 to 3000 ft/min until the FLC speed is reached (240 KIAS below FL 100, 290 KIAS or Mach number 0.65 above); then select FLC.

During climbs through moderate to heavy turbulence where the SPD or FLC modes are ON, changing to the VS mode may prevent the airplane from chasing the speed, which causes wide variations in rate of climb.

CAUTION: THE USE OF THE VS MODE CALLS FOR EXTRA ATTENTION REGARDING THE SPEED OF THE AIRPLANE. AS THE AIRCRAFT CLIMBS ON A CONSTANT RATE OF CLIMB, THE AIRSPEED TENDS TO DECREASE.

Once the airplane levels OFF AT cruise level, the PNF must wait until the airplane reaches Mach 0.70 (or 300 KIAS at lower levels) to select CRZ.

INITIAL CLIMB

Best fuel and time efficiency is obtained by retracting flaps as soon as practicable, considering that a quick climb is important to maximize efficiency. After selection of a vertical mode, verify that climb thrust (CLB) is selected and displayed on the EICAS.

After flaps retraction, the initial climb speed should be chosen based on the operational requirements (obstacles, SID tracks and constraints, weather conditions, noise restrictions, etc.) and company policies, as well as local regulations.

NOTE: It's recommended to closely monitor the TAT indication and presence of moisture. If environmental ice conditions exist, even intermittent, check the windshield, windshield wiper (if installed), and wing surface for ice accumulation. To visualize ice formation, if necessary, use a flashlight on the windshield and the wing inspection light on the wing. If any ice formation is detected or suspected, select the anti-ice protection system override knob to ALL. When flying in detected or suspected ice conditions, use ice speeds as reference.

3-20	Page 2	Code 01
------	-----------	------------

CLIMB PROFILE AND CONSIDERATIONS

In order to choose the AP Modes during climb consider the following:

- FLC mode: it is recommended.
- VS mode: speed of the airplane during climb tends to decrease, therefore increasing workload.
- SPD mode: designed to provide overspeed and under-speed protection. Avoid using in turbulence.

Maintain maximum speed of 240 KIAS up to FL100 and 300 KIAS above.

Use the VS mode with a rate of 2000 to 3000 ft/min until the FLC speed is reached:

- 240 KIAS below FL100;
- For EMB-145 (except XR models): 270 KIAS or Mach number 0.56 above;
- For EMB-145XR Model: 290 KIAS or Mach number 0.60 above), then select FLC.

Once the airplane levels at the cruise level, the PM must wait until the airplane reaches Mach 0.70 (or 300 KIAS at lower levels) to select CRZ THRUST rating.

CLIMB BASED ON VERTICAL GREEN MODES (FD)

The climb to cruise altitude should be preferably done by using the AP FLC mode.

The cabin differential pressure may reach its maximum on lengthy climbs to FL 270 or higher, and this may result in high cabin rates with the consequent passenger discomfort. To avoid this, the following technique can be used:

- When the cabin differential pressure reaches 8.1 psi on the EICAS, select the autopilot VS mode and use a rate of climb of 1500 ft or less, until reaching cruise level.

If the ATC stops the climb momentarily, maintain a maximum speed of:

- if at FL 100 or lower, 240 KIAS, or
- if above FL 100, 300 KIAS.

To restart the climb, reselect the new target altitude with the ASEL button and use the VS mode with a rate of 2000 to 3000 ft/min, until the FLC speed is reached (240 KIAS below FL 100, 290 KIAS or Mach number 0.65 above); then select FLC.

If the ATC stops the climb momentarily, set the altitude pre-selector to the cleared altitude.

During climbs through moderate to heavy turbulence with the SPD or FLC modes ON, changing to the VS mode may prevent the airplane from chasing the speed, which causes wide variations in the rate of climb.

CLIMB BASED ON VERTICAL MAGENTA MODES (VNAV, IF APPLICABLE)

CAUTION: WHEN THE VERTICAL DIRECT-TO IS USED, ALL CONSTRAINTS BETWEEN THE CURRENT AIRPLANE POSITION AND THE SELECTED WAYPOINT ARE REMOVED FROM THE FLIGHT PLAN.

When approaching or leaving any level off altitude, the crew must adjust throttles to the appropriate speed and climb rate. The VTA is also designed to highlight the crew for the necessary thrust settings, as applicable.

The transition to climb initiates automatically when the following conditions are met:

- the altitude preselector is set to a higher altitude, and
- the engine thrust is sufficiently increased.

CAUTION: IF A LATE CLIMB IS REQUIRED, THE CREW MUST SET THE ALTITUDE PRESELECTOR IN THE CURRENT ALTITUDE.

During climb, the VNAV mode uses the VFLCH mode, which commands the A/P with:

- the speed set on PERF INIT page for climb, and
- an altitude constraint or altitude preselector, whichever is lower.

3-20	Page 4	Code 01
------	-----------	------------

The speeds may be changed by revising the PERF INIT data, or using speed intervention. To follow the FMS climb plan, adjust the preselector to the highest altitude cleared by ATC.

CAUTION: DO NOT SET THE PRESELECTOR ALTITUDE TO CRUISE ALTITUDE, AS IT MAY CAUSE A VIOLATION OF AUTHORIZED AEROSPACE.

The crew can change the altitude restriction associated with a waypoint on the CDU or use altitude preselector to include intermediate altitude clearance.

During climbs through moderate to heavy turbulence, evaluate changing to VS green mode, as it may prevent the airplane from chasing the speed, which causes wide variations in the rate of climb.

CAUTION: THE USE OF THE VS MODE CALLS FOR EXTRA ATTENTION REGARDING THE SPEED OF THE AIRPLANE, AS IT CLIMBS ON A CONSTANT RATE OF CLIMB AND THE AIRSPEED TENDS TO DECREASE.

For detailed information regarding VNAV operation, refer to Honeywell FMS 6.1 manual.

User: aherrera - Printed By myTechCare - Aug 09/22 - 14:17:22

CLIMB – ACTIONS AND CALLOUTS

	PF	PM
Transition Altitude	- Pushes the BARO SET (PUSH STD) and crosschecks.	"TRANSITION ALTITUDE" . - Pushes the BARO SET (PUSH STD) and crosschecks.
Upon passing 10000 ft AFE	-	- External lights OFF, except NAV, STROBE and red beacon. - FSTN BELTS signs may be switched OFF upon Captain's consent.

NOTE: Callouts are shown in bold text.

CLIMB SPEEDS

SPEED FOR MAXIMUM CLIMB ANGLE

Maximum Climb Angle Speed provides a maximum altitude gain in a minimum ground distance. With flaps retracted, the V_{FS} is the recommended best angle of climb speed for all operational gross weights and takeoff altitudes.

SPEED FOR MAXIMUM RATE OF CLIMB

Maximum Rate of Climb Speed provides a maximum altitude gain in a minimum flight time. With flaps retracted, the $V_{FS} + 50$ kt is approximately the maximum rate of climb speed for all operational gross weights and takeoff altitudes. Refer to AOM Flight Planning Section for accurate speeds and Mach number, as the Maximum Rate of Climb Speed is a function of gross weight and altitude.

ENROUTE CLIMB

The enroute climb speeds should be selected by the operators to match their operational practices and requirements.

In general, the enroute climb speeds should be attained as soon as practical to improve the flight efficiency, even at altitudes below 10000 ft where the local rules allow.

Usually a constant IAS is selected as enroute climb speed. This IAS is maintained until a certain altitude where this speed intercepts a selected Mach number that should be maintained until cruise altitude.

CLIMB - ACTIONS and CALLOUTS		
	PF	PM
Transition Altitude	- Pushes the BARO SET (PUSH STD on PFD) and crosschecks (*).	“TRANSITION ALTITUDE” . - Pushes the BARO SET (PUSH STD on PFD) and crosschecks (*).
Upon passing 10000 ft AFE	“TEN THOUSAND CHECKED” .	“TEN THOUSAND” . - External lights OFF, except NAV, STROBE and red beacon. - FSTN BELTS signs may be switch OFF upon Captain's consent.

NOTE: - Callouts are shown in bold text.

- (*) For airplanes equipped with Standby Altimeter the standard baro setting should be adjusted by the LSP at the Transition Altitude. For airplanes equipped with Integrated Standby Instrument System (ISIS) the STD button should be pushed at the Transition Altitude by the LSP.

CABIN DIFFERENTIAL PRESSURE

The cabin may reach its maximum differential pressure when climbing to FL 270 or higher and can cause passenger discomfort.

To avoid this when the cabin differential pressure reaches 8.1 PSI on the EICAS, select the autopilot VS mode and use a rate of climb of 1500 ft or less until reaching cruise level.

ENGINE ICE CLIMB

During climb monitor pitch attitude and airspeed continuously, performance changes such as airspeed decrease, reduced climb rate and/or higher than normal pitch angle may be an indication that ice has already accreted on to the airframe. If ice related performance decreases are noted, ensure that all icing systems are selected ON. Make sure the required thrust and attitude are being properly maintained.

Operation in moderate to severe icing conditions may allow ice to build up on the fan spinner and/or blades. If allowed to accumulate, asymmetrical ice shedding may result in high fan vibration. If fan ice build-up is suspected (high indicated or perceived vibration) and, for any reason N1 is below 60%, accomplish the following periodic engine run up (one engine at a time): advance one thrust lever at a time to a minimum of 60% N1 for 5 seconds. Then return the thrust lever to the position required for flight conditions.

Monitor anti-ice systems for proper operation. Apply the associated AFM abnormal procedure in case of system failure. If the failure persists, exit and avoid icing conditions. Make the air traffic controller know you are requesting a change due to icing conditions and keep him informed about it.

NOTE: Engine and Wing Ice Protection Systems operation is automatic and based on the primary ice detection system. However, the crew remains responsible for monitoring icing conditions and for manual activation of the ice protection system if icing conditions are present and the ice detection system is not activating the ice protection system.

3-20	Page 8	Code 01
------	-----------	------------

ONE ENGINE INOPERATIVE CLIMB

After flaps retraction, V_{FS} and Maximum Continuous (CON) thrust should be set or verified until all obstacles have been cleared.

After reaching a safe altitude, higher climb speeds can be employed to improve airplane controllability.

NOTE: Keeping the airplane trimmed at all times will minimize drag increment.

User: aherrera - Printed By myTechCare - Aug 09/22 - 14:17:22



INTENTIONALLY BLANK

User: aherrera - Printed By myTechCare - Aug 09/22 - 14:17:22

3-20	Page 10	Code 01
------	------------	------------

Copyright © by Embraer. Refer to cover page for details.

REVISION 10

SOP-145/1489

CRUISE

GENERAL

This section presents information that is pertinent to the cruise phase of the flight. More in depth performance information is provided in the AOM Vol. 1 - Flight Planning section.

SPEED SELECTION

MAXIMUM CRUISE SPEED

Maximum Cruise Speed provides the maximum True Air Speed (TAS). It is achieved when maximum cruise thrust is used. Using maximum cruise speed, the trip time is reduced and fuel burn increased.

LONG RANGE CRUISE SPEED

In the Long Range Cruise Speed mode, the airplane is flown at a speed corresponding to a specific range equal to 99% of maximum specific range. It is used when range is the main factor in a given route.

CRUISE SPEED MANAGEMENT

Speed variations above the planned speeds may lead to significant trip fuel burn as speed has a large impact on specific range.

The crew should ensure, during walk around that the Pitot Tubes, Total Air Temperature Probe (TAT) and Static Ports delimited areas are clean and free of obstructions, so that it may provide correct speed, Mach number and TAT calculations.

User: aherrera - Printed By myTechCare - Aug 09/22 - 14:17:22

ALTITUDE SELECTION

Tables of Altitude Capability, Flight Level, and the Wind Altitude Trade are presented on AOM Vol 1 Flight Planning section. These tables will be helpful in enabling to use the airplane more efficiently.

ALTITUDE CAPABILITY

For a given speed, weight and thrust, there is a maximum altitude at which straight and level flight is possible. This "Maximum Altitude" is also called "Airplane Ceiling".

The altitude capability can be verified on AOM flight planning section for Maximum Speed Cruise based on initial cruise weight for various ISA conditions and all engines operating with a residual rate of climb of 300 ft / min.

The maximum altitude at which an airplane can fly is limited by three factors:

- Engine thrust.
- Capacity of the wing to generate enough buffet-free lift.
- Operational envelope.

CRUISE - FLIGHT LEVEL TABLE

The AOM 1 Flight Planning section present tables that permits quick determination of the cruise flight level for minimum fuel consumption, based on the trip distance and takeoff weight. For each takeoff weight two different flight levels are calculated (A or B) based on the following assumptions:

- Condition (A): The flight level was calculated based only on minimum fuel consumption. It may result on reduced time in leveled flight for short trip distances.

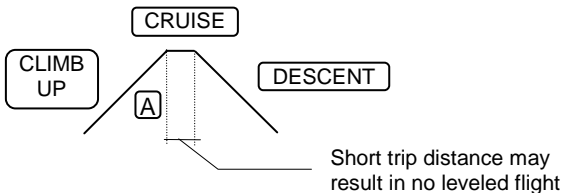

- Condition (B): The flight level was calculated based on a combination of minimum fuel consumption and at least 40% of the total flight time in cruise.

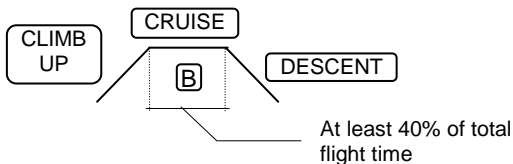

WIND ALTITUDE TRADE

In order to maintain the same ground specific range at another altitude than the one planned initially, Embraer publishes on its AOM 1 Flight Planning section tables which allow the determination of the break-even wind.

The optimum altitude is normally calculated for zero wind, but wind is a factor that may justify operations considerably above or below the optimum altitude.

If the optimum altitude headwind is stronger than lower altitude headwind, for example, it might be advantageous to fly at a lower altitude (and weaker headwind) in order to save fuel. This is called wind-altitude trade.

FLIGHT CONTROLS TRIMMING

AIRPLANE TRIMMING

If the airplane is not properly trimmed for roll and yaw, the autopilot applies primary control displacements to compensate for tendencies, which under some conditions, may significantly increase drag and consequently affect fuel performance.

TRIMMING TECHNIQUE

Yaw Trimming:

With the auto pilot engaged, ensure the fuel is properly balanced, engine thrust is symmetric, and HDG mode is selected.

Proper monitoring of the Slip/Skid Indicator is fundamental for a correct airplane trimming.

The yaw trim switch should be actuated in the direction that corresponds to the Slip/Skid Indicator position and in most cases, only small and brief actuations are sufficient.

To avoid over trimming, allow approximately three to five seconds between actuations and observe the results. As the Slip/Skid Indicator gets closer to the center (below the Roll Pointer) only sharp, brisk actuations are required.

Roll Trimming:

Roll trimming should be performed after the airplane has been trimmed for yaw. An exception to this rule would be a wing heavy condition in manual flight when the slip/skid indicator is centered.

In this case, Roll Trim should be actuated in the same direction where pilot's inputs are needed or towards the down side of the control wheel if a deflection is noticeable. Both parts of the Roll Trim Switch should be pressed simultaneously and in most cases, only sharp, brisk movements are required.

FUEL IMBALANCE

Fuel efficiency can be significantly affected as primary control surfaces are deflected by the auto pilot in order to compensate for the imbalance condition.

A fuel imbalance for which no EICAS message is displayed and has not yet exceeded 360 kg (800 lb) may be regarded as a normal procedure and corrected without the use of the QRH. It is recommended however, to assure no fuel leak is in place.

3-25	Page 4	Code 01
------	-----------	------------

NOTE: If the FUEL IMBALANCE caution message is not displayed on the EICAS and a crossfeed is performed, the advisory message FUEL EQ XFEED OPN will be displayed regardless of the imbalance value, which may lead to an additional imbalance condition.

THROTTLE TECHNIQUE

Rapid and large thrust lever excursions should be avoided, as they can be detrimental to various engines components and can accelerate engine deterioration.

When feasible, large speed changes should be planned in advance. Excessive speed adjustments may cause thrust levers to completely retard and accelerate, which also contributes to engine deterioration and fuel consumption.

TURBULENT AIR PENETRATION

Flight through severe turbulence must be avoided. If not possible, reduce altitude to increase buffet margin.

AIRSPEED

Severe turbulence will cause large and often rapid variations in indicated airspeed. Do not chase the airspeed.

The maximum recommended turbulence air penetration speed can be obtained from the following chart.

At or Below 10000 ft	200 KIAS
Above 10000 ft.....	250 KIAS/0.63 M,
	WHICHEVER
	IS LOWER

User: aherrera - Printed By myTechCare - Aug 09/22 - 14:17:22

MANUAL FLIGHT IN SEVERE TURBULENCE

If manual flight in severe turbulence becomes necessary, trim the airplane for penetration speed and do not change stabilizer position. Control the airplane pitch attitude with the elevators using the attitude indicator as the primary instrument. Do not make sudden large elevator control inputs. Corrective actions to regain the desired attitude should be smooth. Control de airplane attitude first, then make corrections for airspeed, altitude and heading.

DRIFTDOWN

Following an engine failure or inflight engine shutdown, an airplane may not be able to maintain its cruise altitude. The driftdown profile assures the airplane altitude is kept as high as possible throughout the descent. The driftdown speed provides the lower descent gradient.

During a driftdown, the available thrust increases as the airplane descends. Eventually, at a certain altitude the available thrust will become equal to the airplane drag, and the airplane will level off. This altitude is called the gross level off altitude. The gross level off altitude, when corrected by the 1.1% (2 engines), 1.4% (3 engines) or 1.6% (4 engines) gradient margins, is called the net level off altitude and will depend on the atmospheric temperature and the airplane weight.

Regulations (FAR 121.191/JAR-OPS 1.500) require that the airplane be able to clear all terrain by a given margin when an engine fails. Two means of compliance for en-route obstacle clearance are allowed:

- The net level-off altitude must clear all en-route obstacles by at least 1000 ft; or
- The net flight path must clear all en-route obstacles between the point where the engine is assumed to fail and an airport where a landing can be made by at least 2000 ft.

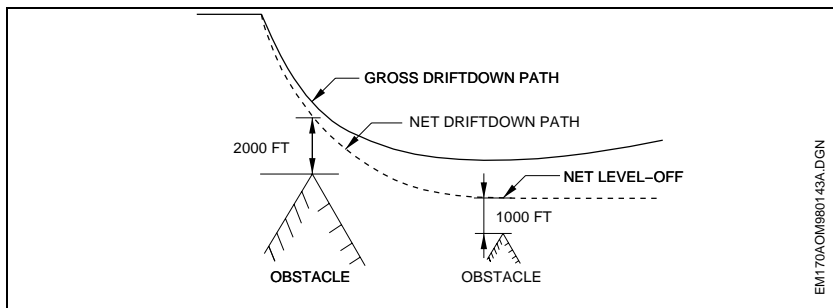

DRIFTDOWN PROCEDURE

After an engine failure or inflight engine shutdown during cruise, if drift down procedure is required, pilots should place thrust lever of operational engine in THRUST SET position and select CON on the Thrust Rating Panel and verify thrust rating to “CON”, adjust altitude selector to appropriate altitude in accordance with route analysis and set driftdown speed. When reaching driftdown speed, pilots select SPD on FGC panel, perform applicable checklist, notify ATC and monitor descent.

User: aherrera - Printed By myTechCare - Aug 09/22 - 14:17:22

**ENGINE EMERGENCIES IN CRUISE – DRIFTDOWN
ACTIONS AND CALLOUTS**

	PF	PM
Failure Identification	<p>“ENGINE _ FAILURE/FIRE (OTHER)” (Pilot first noticing the engine failure / fire (other))</p>	
Preparation for Descent	<ul style="list-style-type: none"> • Sets operative engine thrust lever to THRUST SET and CON on Thrust Rating Panel. • Sets MEA/MORA on Altitude Selector. • Sets Driftdown Speed on SPEED TAPE. • Presses SPD on FGC panel when Driftdown Speed is reached. • RVSM: take heading in accordance with established emergency procedures. 	<ul style="list-style-type: none"> • Inform ATC: report emergency type and intentions. • Turn fasten belts to ON.

User: aherrera - Printed By myTechCare - Aug 09/22 - 14:17:22

**ENGINE EMERGENCIES IN CRUISE – DRIFTDOWN
ACTIONS AND CALLOUTS**

	PF	PM
In case of ENGINE FIRE, SEVERE DAMAGE OR SEPARATION:		
<p>Performing Engine Fire, Severe Damage or Separation Checklist</p>	<p>“MEMORY ITEMS FOR ENGINE _ FIRE, SEVERE DAMAGE OR SEPARATION” “THRUST LEVER 1 (2) IDLE CONFIRM?”</p> <ul style="list-style-type: none"> • Reduces affected eng thrust lever to idle. • Confirms the failed engine Start/Stop selector: “CONFIRMED” • Confirms his (her) hand on the affected engine Fire Extinguisher Handle. “CONFIRMED” 	<ul style="list-style-type: none"> • Confirms that the failed engine is being reduced. “CONFIRMED”. • “START/STOP 1(2) STOP CONFIRM?” • Place hand over the AFFECTED engine Start/Stop selector. • Selects the affected engine Start/Stop selector to STOP. “FIRE EXTINGUISHER HANDLE 1(2) PULL CONFIRM?” • Places hand on the affected engine Fire Extinguisher Handle and wait PF confirmation.

CONTINUES ON NEXT PAGE

SOP-145/1489

REVISION 5

3-25	Page 9	Code 01
------	-----------	------------

CONTINUED FROM PREVIOUS PAGE

ENGINE EMERGENCIES IN CRUISE – DRIFTDOWN ACTIONS AND CALLOUTS		
	PF	PM
Performing Engine Fire, Severe Damage or Separation Checklist	<p>“ENGINE FIRE, SEVRE DAMAGE OR SEPARATION CHECKLIST, I HAVE ATC”.</p> <ul style="list-style-type: none"> • Takes the ATC communications. 	<ul style="list-style-type: none"> • Pulls the affected engine Fire Extinguisher Handle. • Reads the Checklist. “ENGINE FIRE, SEVRE DAMAGE OR SEPARATION CHECKLIST COMPLETED.

User: aherrera - Printed By myTechCare - Aug 09/22 - 14:17:22

**ENGINE EMERGENCIES IN CRUISE – DRIFTDOWN
ACTIONS AND CALLOUTS**

	PF	PM
In case of ENGINE FAILURE/SHUTDOWN:		
<p>Performing Engine Failure/ Shutdown Checklist</p>	<p>“(APPLICABLE ABNORMAL) CHECKLIST, I HAVE ATC”.</p> <ul style="list-style-type: none"> Places his (her) hand on the failed engine Thrust Lever: “THRUST LEVER 1(2) IDLE CONFIRM?” Reduces affected engine Thrust Lever to idle. Confirms the failed engine START/STOP selector: “CONFIRMED”. 	<ul style="list-style-type: none"> Reads the checklist aloud. “THRUST LEVER 1(2) IDLE” Confirms that the failed engine is being reduced. “CONFIRMED”. <p>“START/STOP 1(2) STOP CONFIRM?”</p> <ul style="list-style-type: none"> Place his (her) hand on the failed engine Start/Stop selector. Selects the Start/Stop selector to STOP. Completes the Engine Failure Checklist. <p>“(APPLICABLE ABNORMAL) CHECKLIST COMPLETED”.</p>

CONTINUES ON NEXT PAGE

SOP-145/1489

REVISION 5

3-25	Page 11	Code 01
------	------------	------------

CONTINUED FROM PREVIOUS PAGE

**ENGINE FIRE, SEVERE DAMAGE OR SEPARATION
(ON TAKEOFF AFTER V₁) – ACTIONS AND CALLOUTS**

Descending to
MEA/MORA

- Reevaluate the situation based on:
 - Type and consequences of the emergency;
 - Route obstacles (MEA/MORA);
 - Airplane one-engine ceiling capability.
- Distance to the destination and fuel remaining.

NOTE: - Call outs are shown in “Bold” text.
- Use of autopilot is recommended.

RVSM

Before entering RVSM airspace, the flight crew should review the status of the required equipment. If any required equipment fails prior to entering RVSM airspace, a new ATC clearance should be obtained.

While flying in RVSM airspace:

- Crew should increase the vigilance to prevent deviations from the assigned flight level;
- When changing flight levels, the airplane should not overshoot or undershoot FL by more than 45 m (150 ft);
- The autopilot should be operative and engaged during level cruise, except for circumstances such as the need to re-trim the airplane or when it must be disengaged due to turbulence;
- Crew should notify ATC of contingencies (equipment failures, weather conditions) which affect the ability to maintain the current flight level;
- If unable to notify ATC and obtain a clearance prior to deviating from the cleared flight level, follow established contingency procedures and obtain ATC clearance as soon as possible.

EMERGENCY DESCENT

This maneuver is designed to bring the airplane down to a safe altitude in the minimum amount of time when experiencing a rapid depressurization or any other situation requiring immediate and rapid loss of altitude. This procedure should be accomplishing by the crew members from memory.

During an emergency descent, a permanent communication in the cockpit should be maintained in order to identify a possible pilot incapacitation.

If structural damage is suspected, use flight controls with care, limit speed as appropriate and evaluate the use of landing gear to expedite the descent. When turbulence is encountered, reduce to turbulent air penetration speed.

LOSS OF ALTITUDE

If descending due to cabin depressurization the crew members should don masks and establish communication immediately after, accurately, verifying cabin is depressurizing uncontrollably.

Opening the mask's stowage box automatically initiates the oxygen flow. Pressing the harness inflation control valve will inflate the harness, enabling its quick donning. Releasing the button will deflate the harness firmly fitting it to the head. The mask is designed to be donned within 5 seconds.

To activate the mask's microphone the pilots have to select MASK on the Digital Audio Panel. The selection is made using the BOOM/MASK button.

If required, the speakers have to be activated on the Digital Audio Panel selecting Side Tone knob (S.T.) and adjusting the Speaker Master Volume control knob as required. Once activated the communication reception is possible through the speakers or the headsets.

Oxygen masks are operated at three selectable modes: The NORMAL mode is to be used as a supplemental, when a regular amount of oxygen, diluted with cabin air is capable to maintain a safe physiologic level until a preset altitude, where the user inhales 100% oxygen. The 100% mode is mandatory during an emergency descent, as it's not diluted with cabin air, regardless cabin altitude. The EMER mode is useful to remove smoke and fumes, as it is non-diluted oxygen regardless of cabin altitude with a slightly positive pressure.

REVISION 5

3-25	Page 13	Code 01
------	------------	------------

When the mask is on emergency mode, the air pressure and flow make communication more difficult. To avoid communication disruption it is recommended not to use the EMER setting continuously, selecting the mode back to 100% or Normal after the mask is clear of smoke, fumes or condensation.

Once mask usage is not necessary, pilots must close the oxygen mask storage box doors and press reset button, enabling hand/headset microphone booms.

- This maneuver is designed to bring the airplane down smoothly to a safe altitude in the minimum amount of time when experiencing a rapid depressurization.
- Use of automated resources is recommended.
- If structural damage is suspected, use flight controls with care and limit speed as appropriate.
- Descend straight ahead or initiate turn with HDG selector, in accordance with local regulations.
- If cabin altitude reaches 14000 ft or above, verify the oxygen ON indicator light illuminated on the Passenger Oxygen Control Panel. If the indicator light is not illuminated set the Passenger Oxygen Selector Knob to MANUAL position.
- When turbulence is encountered, reduce to turbulent air penetration speed.
- Altitude callouts are performed every 10000 ft (30000 ft/20000 ft/10000 ft) by the PM to check crew awareness.
- Reevaluate the situation based on weather, oxygen, fuel remaining and available airports before defining the new course of action. The use of long-range cruise may be appropriate.
- RVSM – The Pilot shall follow established emergency procedure, notify ATC and follow the appropriate RVSM contingency procedure for specific RVSM airspace. Use TCAS as a reference in this situation.
- If use of oxygen is required for a long period of time set the Oxygen Masks Selector to NORMAL.

3-25	Page 14	Code 01
------	------------	------------

**EMERGENCY DESCENT/RAPID DEPRESSURIZATION
ACTIONS AND CALLOUTS**

	PF	PM
In Flight	“EMERGENCY DESCENT” .	-
	<ul style="list-style-type: none"> • Don crew oxy masks and check communications. 	
	“MEMORY ITEMS” . <ul style="list-style-type: none"> • Alerts cabin crew (P.A.): “ATTENTION CREW, EMERGENCY DESCENT” .	<ul style="list-style-type: none"> • Selects seat belts sign ON. • Selects no smoking sign ON.
	<ul style="list-style-type: none"> • Sets Thrust Levers to Idle. • Opens Speed Brakes. • Selects altitude (MEA or 10000 ft whichever is higher). • When airspeed reaches 250 KIAS, commands GEAR DOWN and press SPD on Guidance Panel. “GEAR DOWN” .	<ul style="list-style-type: none"> • Selects squawk 7700. • Monitors cabin altitude. • Selects Gear Down.
	<ul style="list-style-type: none"> • Completes final adjustments for Speed and altitude selections. 	<ul style="list-style-type: none"> • Advises ATC: “(Call sign) Emergency Descent” • Checks flight instruments and engine parameters. • Confirms Pax Oxygen (if cabin reaches 14000 ft).

CONTINUES ON NEXT PAGE

CONTINUED FROM PREVIOUS PAGE

EMERGENCY DESCENT/RAPID DEPRESSURIZATION ACTIONS AND CALLOUTS		
	PF	PM
In Flight	-	<ul style="list-style-type: none"> • Monitors descent path and speed.
	<ul style="list-style-type: none"> • After all memory items complete, call for the appropriate QRH procedure. 	<ul style="list-style-type: none"> • Accomplishes checklist.
2000 ft to MEA or 10000 ft	<ul style="list-style-type: none"> • Starts decreasing rate of descent (use FLC at pilot discretion). 	“TWO THOUSAND TO LEVEL OFF” .
1000 ft to MEA or 10000 ft	<ul style="list-style-type: none"> • When speed reaches 200 kias retracts Speed Brakes and commands Gear up. “GEAR UP” .	“ONE THOUSAND TO LEVEL OFF” . <ul style="list-style-type: none"> • Selects Gear Up.
At Safe Altitude	<ul style="list-style-type: none"> • Informs cabin crew. “ATTENTION CREW WE HAVE REACHED SAFE ALTITUDE” .	-

NOTE: Callouts are shown in bold text.

UNRELIABLE AIRSPEED

Unreliable airspeed indications usually are associated with partial pitot static system blocking, damage or frozen as well deterioration of system parts.

The flight crew can recognize an unusual indication monitoring airspeed indications and crosschecking PFD 1, 2 and Standby Airspeed Indicator or ISIS. IAS and ALT miscompare monitor annunciations can be also used to aid pilots to identify this condition.

When this scenario occurs the Autopilot must be disengaged The Flight Director may be also unreliable and should not be followed.

With the Autopilot disengaged the crew must maintain proper control of the airplane by means of pitch attitude and power settings.

AOM Vol.1 and QRH - Emergency and Abnormal Procedures sections present Unreliable Airspeed procedures. The QRH has thrust and pitch settings to be used on each flight phase.

The use of Speedbrake should be avoided since the capacity of the flight crew to monitor the speed change might be compromised.

Under an Unreliable Airspeed scenario, Altitude and/or Vertical Speed indications may also be unreliable.

Ground Speed indication available on PFD and GPS altitude may also be used as reference if PFD indication is unreliable.

At pilot's discretion, when the airplane is stabilized under correct pitch attitude and power setting, instruments should be crosschecked in order to help identifying any possible reliable instrument. In case a reliable source is identified, ADC reversion should be attempted.

User: aherrera - Printed By myTechCare - Aug 09/22 - 14:17:22

AIRPLANE UPSET

An airplane upset is an undesired airplane state characterized by unintentional divergences from parameters normally experienced.

UPSET PREVENTION

Deviations from the desired airplane state will become larger until action is taken to stop the divergence. Therefore, early recognition of airplane state divergences is essential to avoid progression towards a potential upset. Return to the desired airplane state can be achieved through natural airplane reaction to accelerations, autoflight system response or pilot intervention.

Flight crew engagement combats/avoids complacency through active monitoring, which means keeping track of the environment, the airplane's energy state and flight path trajectory. Therefore, active monitoring is the critical element to ensure awareness and avoidance of undesired airplane states and provides the strongest countermeasure against startle.

Desired goals for awareness and prevention include the following:

- Recognition of operational and environmental conditions that increase the likelihood of an upset event occurring.
- Aeronautical decision making skills to prevent upsets (e.g., effective analysis, awareness, resource management, mitigation strategies, and breaking the error chain through airmanship and sound judgment).
- Early detection of flight path divergences.
- Timely and appropriate intervention.
- The effects of autoflight including mode confusion and unexpected disconnection of the autopilot.
- Recognition of when the flight condition has transitioned from the prevention phase into the recovery phase.
- Effective verbal and nonverbal communication regarding the airplane state.

3-25	Page 18	Code 01
------	------------	------------

UPSET RECOVERY

The pilot response to an upset must be appropriate to stop the divergence and to recover the airplane's state. Up to full-scale control deflections may be necessary. However, initiating recovery with arbitrary full-scale control deflections could actually increase the divergence. An excessive or inappropriate control input that overshoots the desired response can startle the pilot and cause one upset to lead to another.

Communication between crew members assists in the recovery actions. At the first indication of a flight path divergence, both pilots should announce what is being observed. It is necessary to use the primary flight instruments when analyzing the upset situation. Visual meteorological conditions may allow the use of references outside the airplane; however, it can be difficult to see the horizon during both high and low pitch attitudes. Pilots must be prepared to analyze the situation during darkness and when instrument meteorological conditions (IMC) exist.

The PFD is a primary reference for recovery.

For Nose High Upset Recovery, the airspeed is normally decreasing, altitude is increasing and the VSI indicates a climb.

For Nose Low Upset Recovery, the airspeed is normally increasing, altitude is decreasing and the vertical speed indicator (VSI) indicates a descent.

The actions listed below must be part of every recovery from an upset:

- Become aware about the airplane's energy state
- Stop the flight path divergence; and
- Recover to a stabilized flight path.

The PM has an important role in the recovery maneuver. The PM should monitor airspeed and attitude throughout the recovery and announce any continued divergence.

The following techniques represent a logical progression for recovering the airplane. While not strictly procedural, the templates represent a consensus view of actions for recovery. If needed, use pitch trim sparingly. Careful use of rudder to aid roll control should be considered only if roll control is ineffective.

NOSE HIGH RECOVERY MANEUVER

A large out-of-trim condition could be encountered if the autopilot is disengaged. If the autopilot is responding correctly to stop the divergence, keep it engaged.

If required, the PF should disengage the autopilot and the PM should confirm that it is disengaged. The PM should monitor attitude and speed of the airplane throughout the recovery and announce any continued divergence.

The PF should apply as much nose-down pitch control and incremental trim input(s) as required to obtain a nose-down pitch rate. Excessive use of pitch down trim can make the recovery phase of the upset more difficult.

If nose-down inputs are not successful in achieving a nose-down pitch rate, pitch may be controlled by rolling the airplane 45° to 60°, or maintain the bank angle if in a turn, until pitch angle is reduced.

Recover to level flight may require use of pitch trim to manage control forces during large airspeed changes. Pilots should monitor pitch command to avoid entering a stall due to premature recovery at low speed or excessive load factor at high speed.

WARNING: EXCESSIVE USE OF PITCH TRIM OR RUDDER MAY INCREASE THE UPSET DIVERGENCE OR MAY RESULT IN HIGH STRUCTURAL LOADS.

3-25	Page 20	Code 01
------	------------	------------

NOSE HIGH RECOVERY MANEUVER - ACTIONS AND CALLOUTS

	PF	PM
Upon recognizing the upset situation.	“UPSET” (Pilot first noticing the upset situation).	
	<ul style="list-style-type: none"> • Disengage Autopilot (if required). • Apply nose-down control input as required to obtain a nose-down pitch rate. • Use thrust as required. • Adjust roll (if required). 	<ul style="list-style-type: none"> • Check Autopilot disengaged. • Monitor airspeed and attitude throughout the recovery and announce any continued divergence.
When airspeed is sufficiently increasing.	<ul style="list-style-type: none"> • Level the wings and recover to level flight. 	<ul style="list-style-type: none"> • Reconfigure the airplane as necessary.

User: aherrera - Printed By myTechCare - Aug 09/22 - 14:17:22

NOSE LOW RECOVERY MANEUVER

A large out-of-trim condition could be encountered if the autopilot is disengaged. If the autopilot is responding correctly to stop the divergence, keep them engaged.

If required, the PF should disengage the autopilot and the PM should confirm that it is disengaged. The PM should monitor attitude and speed of the airplane throughout the recovery and announce any continued divergence.

Even in a nose low situation, the airplane may be stalled. If necessary, the PF must recovery from the stall first, applying nose down inputs, which may not be intuitive.

It is important to reduce load factor while attempting to roll to wings level because it increases the roll effectiveness while decreasing the asymmetric loads on the airplane.

The PF should use Thrust or Speed brakes to control the airspeed. If airspeed is low, apply thrust; if airspeed is high, reduce thrust, and if necessary, extend speed brakes.

Recover to level flight may require use of pitch trim to manage control forces during large airspeed changes. Pilots should monitor pitch command to avoid entering a stall due to premature recovery at low speed or excessive load factor at high speed.

WARNING: EXCESSIVE USE OF PITCH TRIM OR RUDDER MAY INCREASE THE UPSET DIVERGENCE OR MAY RESULT IN HIGH STRUCTURAL LOADS.

3-25	Page 22	Code 01
------	------------	------------

NOSE LOW RECOVERY MANEUVER - ACTIONS AND CALLOUTS

	PF	PM
Upon recognizing the upset situation.	<p>“UPSET”</p> <p>(Pilot first noticing the upset situation).</p>	
	<ul style="list-style-type: none"> • Disengage Autopilot (if required). • Recover from stall (if required). • Roll in the shortest direction to wings level. • Adjust thrust and drag (if required). • Recover to level flight. 	<ul style="list-style-type: none"> • Check Autopilot disengaged. • Monitor airspeed and attitude throughout the recovery and announce any continued divergence. • Reconfigure the airplane as necessary.

User: aherrera - Printed By myTechCare - Aug 09/22 - 14:17:22

STALL

The lift force generated on a surface is a result of its angle of attack (AOA), the dynamic pressure of the air moving around it, which depends on airspeed and air density, and the size and shape of the surface. As the AOA increases, lift increases proportionally.

The lift increases until the wing reaches its maximum AOA, named critical AOA. Beyond the critical AOA, the air flow around the upper side of the wing separates; lift decreases, instead of increasing, and the airplane stall. To sustain a lifting force on the wing, the pilot must ensure that the wing is flown at an angle below the stall angle.

The angle of attack is the angle between the relative wind and the chord line of the airfoil. It should not be confused with the flight path angle or the pitch attitude. In the ERJ-145 it is not possible to read or estimate the AOA value, once there is no flight path angle indication on the PFD. However, the approach to critical AOA (and stall) can be identified through the LSA (Low Speed Awareness) and PLI (Pitch Limit Indicator) indications, according to the proper color code.

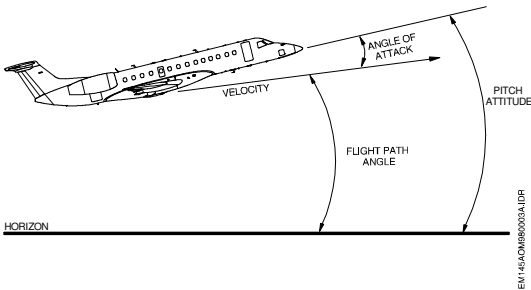
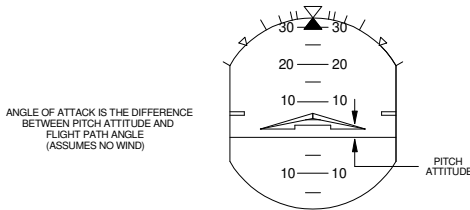

3-25	Page 24	Code 01
------	------------	------------

Note that, being the lift generation directly related to the airplane AOA, the stall can occur at any point of the airplane flight envelope. At high-speed cruise, or during descents, when it seems that there is plenty of airspeed, the wing can stall. In other words, the stall can occur at any attitude, altitude, speed and load factor.

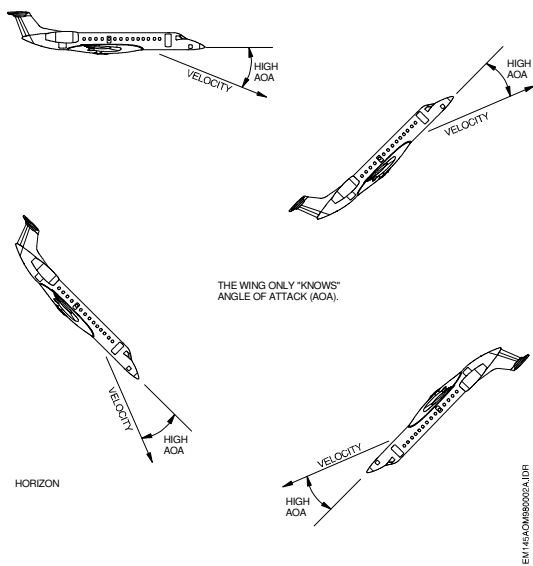

Speed and altitude affect the stall as follows: as altitude increases, the indicated airspeed at which low speed buffet occurs increases. As altitude increases, high-speed buffet speed decreases. Using buffet boundary charts or referencing to g margins allow pilots to determine how high or how fast they can go.

During flight in icing conditions, the airplane may stall at much higher speeds and lower angles of attack than normal. In icing conditions, the activation of the stick shaker is anticipated. The PLI and LSA indication are adjusted to cope with the altered stall onset characteristics.

In all conditions, an effective recovery will be achieved by pushing the elevator control forward. The emphasis of the stall recovery maneuver is to reduce the AOA by putting the airplane in a nose down attitude.

User: aherrera - Printed By myTechCare - Aug 09/22 - 14:17:22

APPROACH TO STALL

In low speed situations an artificial stall warning is provided in advance to the aerodynamic stall in the form of stick shaker (artificial stall warning). At high altitudes, wing buffeting (natural stall warning) can occur prior to the stick shaker.

FULL STALL

Upon Stick Shaker activation or feeling the stall buffeting, if no corrective action is taken and the airplane is on the verge of entering a stall, the stick pusher is actuated, which pitches the nose down.

STALL RECOVERY MANEUVER

Upon recognizing a stall condition, stick shaker activation or feeling the stall buffeting, the crew must initiate the stall recovery procedure immediately.

NOTE: Stick shaker activation causes the automatic disengagement of the autopilot. Beware that, in icing, the autopilot may mask heavy or asymmetric control forces due to airframe icing. The autopilot may even disconnect earlier because of excessive roll rates, roll angles, or excessive pitch.

The PF must reduce the AOA. Push the control column to apply nose down, level the wings and apply maximum thrust. If the stick pusher actuates, do not oppose it, and continue to apply nose down. The PM must confirm autopilot is disengaged, and monitor altitude and speed of the airplane.

The PF must retract the speed brake and maintain the nose down command until the airplane is effectively out of the stall condition. With the airplane out of stall the stall warnings are deactivated.

The ERJ145 airplane has tail mounted engines, whose line of thrust is above the airplane center of gravity. Consequently, the increase of thrust can help the stall recovery maneuver. Additionally, setting the thrust levers to MAX position automatically retracts the speed brakes, reducing the workload during the recovery maneuver.

3-25	Page 26	Code 01
------	------------	------------

Due to the nose down attitude, during the recovery the airplane accelerates. The PM should monitor the speed to avoid the airplane flying above the V_{MO}/M_{MO} or other applicable speed limit. The PM should also monitor and inform any other airplane limitation exceedance. At high altitudes, normally smooth and small control inputs are required to keep speed and rate of climb within reasonable values.

Once out of stall, return the airplane to the normal flight path. Apply commands gradually to avoid secondary stalls. It may take less force to generate the same load factor as altitude increases.

A common template to deal with stall recoveries to all types of airplanes is desirable.

User: aherrera - Printed By myTechCare - Aug 09/22 - 14:17:22

STALL RECOVERY MANEUVER - ACTIONS AND CALLOUTS

	PF	PM
<p>Upon Stick Shaker activation or feeling the stall buffeting.</p>	<p>“STALL ” (Pilot first noticing the stall situation).</p>	
	<ul style="list-style-type: none"> • Disengage Autopilot⁽¹⁾. • Applies nose down and levels the wings until out of stall. • Moves both Thrust Levers to MAX. • Accelerates the airplane to a safe speed. • Retracts speed brakes. • After recovery, return to the normal flight path. 	<ul style="list-style-type: none"> • Check Autopilot disengaged. • Monitors altitude and speed. Performs any necessary callout. • Reconfigures the airplane as necessary.

NOTE: ⁽¹⁾ At high altitudes pilot may feel the stall buffeting before the stick shaker. In this case pilot shall disengage the autopilot.

After recovery, if the airplane is in landing configuration, retract landing gear and flaps as in a normal go-around procedure.

User: aherrera - Printed By myTechCare - Aug 09/22 - 14:17:22

DESCENT

GENERAL

NOTE: It's recommended to closely monitor the TAT indication and presence of moisture. If environmental ice conditions exist, even intermittent, check the windshield, windshield wiper (if installed), and wing surface for ice accumulation. To visualize ice formation, if necessary, use a flashlight on the windshield and the wing inspection light on the wing. If any ice formation is detected or suspected, select the anti-ice protection system override knob to ALL. When flying in detected or suspected ice conditions, use ice speeds as reference.

Even though descent fuel consumption has a minor impact comparing with other flight phases, it is important to plan a correct descent profile. Good descent planning is also necessary to arrive at the desired altitude with correct speed and configuration.

DESCENT SPEEDS

When leaving the cruise level with the approach briefing completed and speed bugs set, the PF requests the descent check list and PM challenge and answer.

In order to choose the AP Modes during descent, consider the following to be performed by PF:

- ASEL on FGC: select desired altitude and use the following modes as necessary:
 - FLC: press and wait start descent;
 - VS: select desired rate of descent; or
 - SPD: select desired speed and avoid to use in turbulence.
- Thrust Levers: adjust as necessary.

* As a suggestion the following technique can be used:

- ASEL on FGC: select desired altitude.
- FLC: press and wait start descent, adjusting the Power to maintain Cruise Mach or 310 kt until passing 11000 ft where Thrust Levers are reduced to Idle in order to pass 10000 ft with 250 KIAS or below.

Below 10000 ft:

- Max Speed: 240 kt or 200 kt in turbulence.

If necessary, use speedbrakes to correct the descent profile. For small adjustments, allow the airspeed to vary initially, using the speed brakes at a lower altitude if further speed adjustments are required.

The pilot should keep a hand on the speedbrakes lever anytime the speedbrakes are used. This will prevent the speedbrakes from being left extended when no longer required.

INITIAL DISTANCE TO DESCENT

Use this guidance as a reference to estimate the “Top of Descent” (TOD) by taking the difference between the cruise altitude and the initial approach altitude (in thousands of feet), multiply it by three and add 10 NM.

Ex. Cruise altitude: 35000 ft

Initial Approach Altitude = 2000 ft

$$TOD = (35 - 2) \times 3 + 10 = 109 \text{ NM}$$

If a descent angle of 3° is taken:

- Calculate the difference between actual flight level and the desired flight level. Divide this value by 10 and multiply by 3.

$$Dist = 3 \times \frac{FL_{Difference}}{10}$$

NOTE: - Deceleration from normal descent speed to 250 kt was considered.

- Deceleration segment and wind effects were not considered.

3-30	Page 2	Code 01
------	-----------	------------

REVISION 5

Example:

If a descent angle of 3° is taken:

$$Dist = 3 \times \frac{(350 - 70)}{10} = 84 NM$$

GREEN MODE

The descent can be initiated by selecting FLC after having set the desired target altitude on the ASEL. Use thrust as necessary to maintain the cruise Mach number previously set when in cruise flight, until reaching 310 KIAS. From this point on, the speed of 310 KIAS should be maintained until passing 11000 ft.

In some cases, depending on the weight of the airplane, the use of SPEED BRAKE and/or the autopilot VS mode may be necessary to decelerate the airplane.

ALTERNATIVE DESCENT TECHNIQUE

Alternatively, an economic descent technique can be used. In this case, the altitude difference is divided by four instead of three. The economic descent is initiated by selecting FLC to ensure a smooth transition. Once the airplane rate of descent achieves 2000 ft/min, VS mode must be selected to adjust the rate of descent to 3000 ft/min until reaching 10000 ft. Then, adjust the rate of descent to 1000 ft/min.

DESCENT SPEEDS

When leaving the cruise level with the approach briefing completed and speed bugs set, the PF requests the descent checklist, PM challenges and answers.

In order to choose the AP Modes during descent, consider the following to be performed by PF:

- ASEL on FGC: select desired altitude and use the following modes as necessary:
 - FLC: press and wait for the start of descent;
 - VS: select desired rate of descent; or
 - Speed Selector: set desired speed. Avoid to use this mode in turbulence.
 - Thrust Levers: adjust as necessary.

As a suggestion, the following technique can be used:

- ASEL on FGC: select desired altitude.

3-30	Page 4	Code 01
------	-----------	------------

- FLC: press and wait for the start of descent, adjusting the thrust to maintain Cruise Mach or 310 kt until passing 1000 ft where Thrust Levers are reduced to Idle in order to pass 10000 ft with 250 KIAS or less.

Below 10000 ft:

- Speed: 250 KIAS or 200 KIAS in turbulence.

If necessary, use speedbrakes to correct the descent profile. For small adjustments, allow the airspeed to vary initially, using the speed brakes at a lower altitude if further speed adjustments are required.

The pilot should keep a hand on the speedbrakes lever anytime the speedbrakes are used. This action prevents the speedbrakes from remaining opened when no longer required.

DESCENT BASED ON VERTICAL MAGENTA MODES (VNAV, IF APPLICABLE)

CAUTION: WHEN THE VERTICAL DIRECT-TO IS USED, ALL CONSTRAINTS BETWEEN THE AIRPLANE AND THE SELECTED WAYPOINT ARE REMOVED FROM THE FLIGHT PLAN.

Before descent, the crew must verify VNAV is engaged, and the FMS Settings are appropriate for VNAV.

CAUTION: HIGH DIFFERENCES BETWEEN CRUISE AND DESCENT SPEEDS OR HIGH DESCENT ANGLES ON FMS SETTINGS MIGHT CAUSE UNCOMFORTABLE PITCH CHANGES.

On PERF INIT Page 2, verify the descent schedule. Specifically, compare cruise and descent speeds, or check descent angle.

For high speed differences or high angles, consider using VS mode to descend.

If VFLCH is intended, and speed differences are high, adjust speed from current cruise speed to desired descent speed. If necessary, use speed intervention to reduce the airplane speed before TOD.

If VPATH is intended, and descent angle is high, to intercept the descent with a lower path angle, use the vertical direct-to function after passing the TOD.

CAUTION: WHEN THE VERTICAL DIRECT-TO IS USED, ALL CONSTRAINTS BETWEEN THE CURRENT AIRPLANE POSITION AND THE SELECTED WAYPOINT ARE REMOVED FROM THE FLIGHT PLAN.

For detailed information regarding VNAV features, refer to Honeywell FMS 6.1 manual.

INITIAL DISTANCE TO DESCENT

VNAV mode keeps the airplane as high as possible for as long as possible. TOD is automatically calculated using the inputs from the FMS flight plan.

CAUTION: TO AVOID HIGH PITCH CHANGES, REDUCE THE DIFFERENCE FROM CRUISE TO DESCENT SPEED BY ADJUSTING THRUST WHEN VTA SOUNDS.

The transition to descent initiates automatically at TOD when the altitude preselector is set to a lower altitude. VPATH is automatically engaged. If VFCL is desired, it must be selected on the FGC panel and properly set. If a late descent is required, the crew must set the altitude preselector in the current altitude.

3-30	Page 6	Code 01
------	-----------	------------

MAGENTA MODE

Based on the continuous and closed flight plan from the FMS, the descent sequence is as follows:

Before descent, adjust speed and thrust to reduce the difference between cruise and descent speeds.

CAUTION: HIGH DIFFERENCES BETWEEN CRUISE AND DESCENT SPEEDS OR HIGH DESCENT ANGLES MIGHT CAUSE UNCOMFORTABLE PITCH CHANGES.

PF selects the desired vertical navigation mode. Descent schedule is as follows:

- VPATH mode: follows the target path angle from PERF INIT page, and respects the FMS altitude constraints.

CAUTION: THE PF MUST MANUALLY ADJUST THRUST TO CONTROL SPEED.

- VFLCH mode: follows the target speed from PERF INIT page, and levels-off at an altitude constraint or at the altitude preselector, whichever is higher. Speed is controlled via pitch command from FD/AP.

CAUTION: THE PF MUST MANUALLY ADJUST THRUST TO CONTROL DESCENT RATE.

When leaving the cruise level with the approach briefing completed and speed bugs set, the PF requests the descent checklist, PM challenges and answers.

PM checks appropriate vertical mode armed, and then engaged (at TOD).

PF adjust thrust accordingly, monitoring speed and altitude constraints.

If VPATH is used, just before the desired descent speed is reached, the PF adjusts the throttles accordingly.

PF and PM monitor speed, altitude, and descent rate, as appropriate.

ACTIONS AND CALLOUTS

DESCENT AND PRECISION APPROACH ACTIONS AND CALLOUTS		
	PF	PM
Prior to start descent	<ul style="list-style-type: none"> -Performs approach briefing (airplane status, fuel, NOTAMs, weather, MORA/MEA/MSA, basic statement for CAT I, work distribution, and taxi-in route). -Sets and crosschecks the following items as required for the approach type: <ul style="list-style-type: none"> - NAV approach frequencies; - Approach course. - Checks approach speeds. <p>"DESCENT CHECKLIST".</p>	<ul style="list-style-type: none"> - Calculates approach speeds. - Sets and crosschecks the following items as required for the approach type: <ul style="list-style-type: none"> - NAV approach frequencies; - Approach course. - Checks approach Speeds. - Pushes in Windshield Heating Buttons and checks/sets the airport elevation at the Pressurization Panel. <p>"DESCENT CHECKLIST COMPLETED".</p>

NOTE: Callouts are shown in bold text.

3-30	Page 8	Code 01
------	-----------	------------

REVISION 10

ICE CONDITION

Observe normal procedures contained in the approved AFM.

When using the autopilot, monitor pitch attitude and speed continuously.

NOTE: Engine and Wing Ice Protection Systems operation is automatic and based on the primary ice detection system. However, the crew remains responsible for monitoring icing conditions and for manual activation of the ice protection system if icing conditions are present and the ice detection system is not activating the ice protection system.

CAUTION: EVEN SMALL ACCUMULATION OF ICE ON THE WING LEADING EDGE MAY CHANGE THE STALL CHARACTERISTICS OR THE STALL PROTECTION SYSTEM WARNING MARGIN.

RNP 0.3

PREFLIGHT CONSIDERATIONS

The pilot must refer to the specific airplane/operators letter of authorization (LOA) operations manual for the specific equipment, training and operational procedure requirements. In addition to the requirements of this Section, the operator must continue to ensure compliance with the general RNAV operating requirements; checking notice to airmen (NOTAM), availability of navigation aids (NAVAID), airworthiness of airplane systems, and aircrew qualification.

INTENTIONALLY BLANK

3-30	Page 10	Code 01
------	------------	------------

Copyright © by Embraer. Refer to cover page for details.

REVISION 10

SOP-145/1489

User: aherrera - Printed By myTechCare - Aug 09/22 - 14:17:22

HOLDING

GENERAL

A holding procedure is a predetermined maneuver which keeps an airplane within a specified airspace while awaiting further clearance.

EMBRAER provides information in the AOM Flight Planning section for Holding airspeed, Fuel Flow, and Fuel Consumption for various airplane configurations. Such information is calculated for the minimum fuel consumption condition.

Considering fuel conservation aspects, flying a holding pattern with flaps extended should be avoided since it significantly increases fuel consumption. For flaps 9°, fuel flow increases by approximately 8.5%.

Maintain clean configuration:

- Landing Gear UP.
- Flaps UP.
- 180 KIAS.

NOTE: It's recommended to closely monitor the TAT indication and presence of moisture. If environmental ice conditions exist, even intermittent, check the windshield, windshield wiper (if installed), and wing surface for ice accumulation. To visualize ice formation, if necessary, use a flashlight on the windshield and the wing inspection light on the wing. If any ice formation is detected or suspected, select the anti-ice protection system override knob to ALL. When flying in detected or suspected ice conditions, use ice speeds as reference.

The holding pattern maneuver is completed when the airplane is established on the inbound course after executing the appropriate entry.

HOLDING IN ICING CONDITIONS

Observe the procedures contained in the approved AFM.

Maintain clean configuration:

- Landing Gear UP.
- Flaps UP.
- Minimum airspeed of 200 KIAS.

CAUTION: MAINTAIN A MINIMUM AIRSPEED OF 200 KIAS SINCE EVEN SMALL ACCUMULATIONS OF ICE ON THE WING LEADING EDGE MAY CHANGE THE STALL CHARACTERISTICS OR THE STALL PROTECTION SYSTEM WARNING MARGIN.

Operation in moderate to severe icing conditions may allow ice to build up on the fan spinner and/or blades. If allowed to accumulate, asymmetrical ice shedding may result in high fan vibration. If fan ice build-up is suspected (high indicated or perceived vibration), accomplish the following periodic engine run up (one engine at a time): advance one thrust lever at a time to a minimum of 60% N1 for 5 seconds. Then return the thrust lever to the position required for flight conditions.

Monitor anti-ice systems for proper operation. Apply the associated AFM abnormal procedure in case of system failure. If the failure persists, exit and avoid icing conditions. Make the air traffic controller know you are requesting a change due to icing conditions and keep him informed about it.

NOTE: Engine and Wing Ice Protection Systems operation is automatic and based on the primary ice detection system. However, the crew remains responsible for monitoring icing conditions and for manual activation of the ice protection system if icing conditions are present and the ice detection system is not activating the ice protection system.

ONE ENGINE INOPERATIVE HOLDING

In case of holding with one engine inoperative, the same procedure for holding with all engines operating is to be used, with some peculiarities due to the loss of one engine.

EMBRAER provides information in the AOM Flight Planning section for Holding airspeed, Fuel Flow, and Fuel Consumption for various airplane configurations. Such information is calculated for the minimum fuel consumption condition.

User: aherrera - Printed By myTechCare - Aug 09/22 - 14:17:22

SOP-145/1489

REVISION 5

3-32	Page 3	Code 01
------	-----------	------------

INTENTIONALLY BLANK

APPROACH

GENERAL

NOTE: It's recommended to closely monitor the TAT indication and presence of moisture. If environmental ice conditions exist, even intermittent, check the windshield, windshield wiper, and wing surface for ice accumulation. To visualize ice formation, if necessary, use a flashlight on the windshield and the wing inspection light on the wing. If any ice formation is detected or suspected, select the anti-ice protection system override knob to ALL. When flying in detected or suspected ice conditions, use ice speeds as reference.

This chapter outlines recommended normal and abnormal operating practices and techniques for precision, non-precision, circling and visual approaches, as well as missed approach and go-around maneuvers.

FUEL CONSUMPTION

The fuel consumption during the approach phase is influenced by two main factors:

- ATC requirements;
- Pilot's flying techniques.

ATC requirements, such as accomplishing of the entire range of IFR approach procedures and holdings are external factors that are a function of airspace capacity and traffic flow management. They are beyond flight crew control.

THRUST USE

As the airplane enters the final approach proper thrust should be established to guarantee a stable approach. Approaching the touch down point, reduce the rate of descent and thrust levers to idle.

FLAPS AND GEAR EXTENSION

The table below shows the flap maneuvering speeds during a visual approach or during an instrument approach:

		FLAP MANEUVERING SPEED (KIAS)			
		BELOW MSLW*		ABOVE MSLW*	
FLAPS	GEAR	NO ICING CONDITIONS	WITH ICING CONDITIONS	NO ICING CONDITIONS	WITH ICING CONDITIONS
0°	Up	180	200	180	200
9°	Up/Dn	160			
18°/22°	Up/Dn	140	150		
45°	Dn	140			

*Maximum Structural Landing Weight as specified on Limitations Section.

FLAP MANEUVERING SPEEDS

NOTE: These speeds allow an inadvertent 15° overshoot beyond the normal 30° bank and provide 1.3 g margin over stick shaker speed. They are valid for all weights up to the maximum structural landing weight.

FLAPS CHOICE

The use of Flaps 22 provides lower fuel consumption and reduced approach noise levels. An assessment should be performed in order to evaluate the best option between Flap 22 and 45 to achieve best values of fuel consumption and noise considering available runway landing length.

NOTE: As long as the stabilized approach criteria are met, the moment of flap and gear extension may be delayed. This instruction is also mentioned in the flight patterns of the precision, low visibility, and non-precision approach and also in the actions and callouts tables.

3-35-01	Page 2	Code 01
---------	-----------	------------

INSTRUMENT APPROACHES

Approximately 50 NM before descent, pilots should perform the approach briefing.

It's recommended to set instruments before the briefing.

The items to be covered by the briefing are:

- Weather and NOTAM's at destination and alternate airports;
- Runway length, width and best taxiway to vacate;
- Landing flaps and deceleration devices (brakes, spoilers and thrust reversers);
- Assessment of the landing distance for current conditions and comparison with the runway length available;
- Check MORA/MEA;
- Instrument Approach plates, checking MSA, frequencies, courses, MDA/DA, selecting raw data sources (CDIs/needles – VOR/FMS/ADF) and use of FMA modes during approach;
- FMS/MCDU settings, checking on each leg that the altitude constraints during descent are assigned as DES on FPL page. Check HOLDING patterns at HOLD page;
- Missed approach procedures – check if it's set on FMS according to the plate;
- Apron facilities and stands.

Pilots must keep close attention to the altitude and speed restrictions according to the charts. Some airports are provided with contingency and special procedures.

Speeds must be set according to the weight and flap selection, considering weather status (CAT II, ICE conditions, etc).

Based on the information available, such as NOTAMs, weather reports and forecast, ATC reports or PIREPs, the crew should evaluate the landing distance for the current conditions and compare the calculated distance with the runway distance available. If conditions change during descent and approach the crew should consider the impacts of that change on the required landing distance. At pilot's discretion a reassessment of the conditions should be done and a maximum performance landing should be considered.

If installed, thrust Reversers must be briefed in order to decide which taxiway is supposed to be used to vacate the runway. Pilots must evaluate runway conditions like slippery and contaminated. It is necessary to discuss the outcome on the landing distance during the approach briefing. This detail, together with wind gusts on surface will affect the landing distance in case of crew planned to use additional speed for the approach.

Airplane status and operational restrictions must be discussed during the briefing. If any failure that affects the required landing distance occurs in the final approach, consider a missed approach in order to better evaluate the situation and an appropriate runway length. Failures that affect the landing distance are commonly associated to brakes, ground spoilers and/or thrust reversers.

It's recommended to perform an instrument crosscheck as soon as cleared by ATC to intercept the final approach course. At this time pilots crosscheck radios and minimums for that specific approach. For far ILS captures, verify if intercepted course is in accordance with the MARKERS indications and the PFD MAP display. If any discrepancy is found disengage the AP and take the appropriate corrective action.

The altimeter setting must be done when passing Transition Level, or according to ATC.

3-35-01	Page 4	Code 01
---------	-----------	------------

BASIC APPROACH MODES

- Pilot is responsible for monitoring all phases of the approach and calls out any observed discrepancies:
 - Any deviation from the flight director guidance – **“GUIDANCE”**.
 - Rate of descent in excess of 900 ft/min – **“SINK RATE”**.
 - Airspeed above Target Speed + 10 kt – **“SPEED”**.
 - Airspeed below Target Speed - 5 kt or below V_{RF} , whichever is higher – **“SPEED”**.
 - Localizer deviation in absence of flight director - **“LOC”**.
 - Glide Slope or FMS vertical deviation in absence of the flight director **“GLIDE”**.
 - Any Autopilot malfunction – calls the failure.
 - Flight director failure to arm or to engage the next expected mode – calls the failure.
 - Perform the callouts in case the EGPWS fails to do so automatically – calls the crossing altitude.

DECISION ALTITUDE/HEIGHT

The ILS CAT I decision altitude is based on barometric altimeter (BARO) and CAT II / III decision height is based on the radio altimeter (RA).

STABILIZED APPROACH

The airplane should be stabilized by 1000 ft AFE if in IMC conditions and no lower than 500 ft AFE if in VMC conditions. An approach is considered stabilized when all of the following criteria are met:

- The airplane is on the correct flight path;
- Only small changes in heading/pitch are required to maintain the correct flight path;
- The airplane speed is not more than $V_{REF} + 20$ kt indicated airspeed and not less than V_{REF} ;

NOTE: SPS ADVANCED caution message indicates that the Stall Protection System trigger speeds have been increased and, therefore, ice speeds must be used. When ice conditions are suspected or detected on Approach, use landing distance for ice condition speeds.

- The airplane is in the correct landing configuration;
- Sink rate is no greater than 1000 ft/min; if an approach requires a sink rate greater than 1000 ft/min, a special briefing should be conducted;
- Power setting is appropriated for the airplane configuration;
- All briefings and checklists have been conducted;
- ILS approaches should be flown within one dot of the glide slope and localizer.

NOTE: For EASA operators the following criteria are also applicable:

- Maximum Bank Angle 30°;
- Sink rate no greater than 1000 ft/min with a maximum deviation of +/- 300 ft/min.

3-35-01	Page 6	Code 01
---------	-----------	------------

LANDING SPEEDS

CAT I, NON-PRECISION AND VISUAL APPROACHES

FLAP SETTING: 22° OR 45°

V_{REF} setting

The V_{REF} speeds for FLAP 22° and 45° are presented on “landing climb and reference speeds” table. Refer to QRH performance section or AOM Vol.I (1-04-25).

- NOTE:** - AFM landing performance considers the threshold is crossed at the screen height of 50 ft and at V_{REF} or V_{REF NEW}.
- No corrections are applied for tailwinds.

For landings in abnormal conditions that require speed correction derived from the QRH, a new V_{REF} must be defined with the information from the AOM/QRH, where:

$$V_{REF\ NEW} = V_{REF\ FLAPS\ 45} + \text{abnormal speed correction}$$

- NOTE:** For EASA operators, if the EICAS message **SPS/ICE SPEEDS** is displayed, the approach speeds and V_{REF} must be adjusted for **ICE ENCOUNTER** regardless of the icing condition upon landing.

V_{APP} setting

The following method may be used for wind additive corrections to define V_{APP}:

$$V_{APP} = V_{REF} + \frac{1}{2} \text{ steady headwind component} + \text{gust increment above steady wind}$$

- NOTE:** - Minimum V_{APP} = V_{REF} + 5 kt.
 - Maximum V_{APP} = V_{REF} + 15 kt (Flaps 45°) or
 V_{APP} = V_{REF} + 20 kt (Flaps 22°).

For landings in abnormal conditions with or without the EICAS message SPS/ICE SPEEDS active, the minimum V_{APP} = V_{REF NEW} + 0 kt and maximum V_{APP} = V_{REF NEW} + 15 kt.

V_{APPCLB} setting

The V_{APPCLB} speeds are presented on “landing climb and reference speeds” table. Refer to QRH performance section or AOM Vol. I (1-04-25).

For landings in abnormal conditions, set V_{APPCLB} equal to the higher between new V_{REF} and V_{APPCLB} from the approach and landing speeds table.

V_{FS} setting

For V_{FS} setting refer to AOM/QRH “landing climb and reference speeds” table.

3-35-01	Page 8	Code 01
---------	-----------	------------

CAT II AND CAT III APPROACHES WITH AP OR FD

FLAP SETTING: 22°

V_{REF} setting

ANAC/FAA consider that the reference speeds for CAT II and CAT III operations are **V_{REF 22}**, the same as CAT I.

EASA considers that the reference speeds for CAT II and CAT III operations are the **V_{REF 22}** (After Ice Encounter) regardless of SPS/ICE SPEEDS being displayed on EICAS.

For landings in abnormal conditions that require speed correction derived from the QRH, a new **V_{REF}** must be defined with the information from the AOM/QRH, where:

$$\mathbf{V_{REF\ NEW} = V_{REF\ FLAPS\ 45} + abnormal\ speed\ correction}$$

- NOTE:** - AFM landing performance considers the threshold is crossed at the screen height of 50 ft and at **V_{REF}** or **V_{REF NEW}**.
- No corrections are applied for tailwinds.

V_{APP} setting

The following method may be used for wind additive corrections to define **V_{APP}**:

$$\mathbf{V_{APP} = V_{REF} + \frac{1}{2}\ steady\ headwind\ component + gust\ increment\ above\ steady\ wind}$$

- NOTE:** - Minimum **V_{APP} = V_{REF 22} + 0 kt.**
 - Maximum **V_{APP} = V_{REF 22} + 20 kt.**

For landings in abnormal conditions with or without the EICAS message STAL PROT ICE SPEEDS active, the minimum **V_{APP} = V_{REF NEW} + 0 kt** and maximum **V_{APP} = V_{REF NEW} + 15 kt.**

V_{APPCLB} setting

The V_{APPCLB} speeds are presented on “landing climb and reference speeds” table. Refer to QRH performance section or AOM Vol. I (1-04-25).

For landings in abnormal conditions, set V_{APPCLB} equal to the higher between new V_{REF} and V_{APPCLB} from the approach and landing speeds table.

INITIAL APPROACH

Both pilots should avoid “heads-down” during the approach, especially in high density traffic.

The initial approach procedure may be flown using LNAV (preferred) or HDG mode for lateral tracking, and FLC or VS mode for altitude changes.

FMS AS PRIMARY SOURCE

The FMS supports the following non-precision approach types: GPS only, RNAV, VOR, VOR/DME, NDB and NDB/DME.

Final approach segment of ILS, LOC, LOC-BC, LDA, SDF, GLS, MLS, Visual, and Radar final approaches using the FMS as the navigation source for guidance are prohibited.

The FMS must be operated as at least a single system, with a minimum of one PFD and one MFD operational prior to commencing the approach. The signal of the station(s) that defines the approach and on board equipment must be verified operational prior to commencing the approach.

If required by local regulations to maintain a raw data crosscheck throughout the procedure both pilots must select the bearing pointer and radio frequency to the station where the procedure is based.

The DGRAD annunciator must be off throughout the approach. If the DGRAD turns on, the FMS as the navigation source must not be used for the remainder of the approach. The flight crew continues the approach using raw data or performs the missed approach procedure.

3-35-01	Page 10	Code 01
---------	------------	------------

REVISION 5

NOTE: FMA should be observed after changing a flight mode to ensure that the correct mode has been selected and is being reflected by the airplane behavior.

FMS DATABASE

The procedure to be flown must be retrieved from the FMS database and a thorough verification of all waypoints, tracks, distances, glide path angles, altitude constraints and threshold crossing altitudes must be enforced and should be addressed on approach briefings.

PILOT INTERVENTION TO THE DATABASE

LATERAL

No changes in the lateral flight plan are allowed beyond the IAF.

VERTICAL

The altitude constraints can only be modified to higher altitudes but the altitude over FAF must not be changed since it changes the final path descent angle.

GPS APPROACHES

If the flight is being dispatched for a GPS approach, the predictive RAIM for the destination should be checked before takeoff.

LOC ONLY APPROACHES

On LOC only approach when cleared to intercept the localizer, the transition from FD modes LNAV, VNAV must be as follows:

- Select an appropriate FD vertical mode;
- Select FD HDG mode;
- Arm FD LOC mode pressing NAV button on the Guidance panel.

PROCEDURE TURN

Procedure turns are used to reverse course during an approach. A procedure turn is only available from approaches in the navigation database or via raw data.

If a full procedure turn is required, plan to have flaps 9 on the outbound track. On inbound track, or 1 dot to glide slope, select flaps 22 and gear down.

A normal outbound track is 45 seconds to 1 minute. Some procedures turns are specified by a procedure track in the NAV charts. The turns must be flown as depicted and monitor in the PFD. The ground speed and the airplane position relative to the procedure turn should be monitored.

MALFUNCTIONS

Any airplane malfunction requiring crew action below 1000 ft AFE under IMC should lead to a go around.

Malfunctions above 1000 ft AFE are to be evaluated by the crew and should lead to a go around if necessary procedures can not be completed before reaching 1000 ft.

NOTE: - In case of any failure that affects the flight director approach mode capability or the ability to continue on the same approach category above 1000 ft AFE, the decision to continue on a downgraded approach category must be made if the missed approach considerations and the new approach minimums have been set at or above 500 ft AFE, and no other checklists or procedures are required below 1000 ft.

- In case of go-around follow the normal go-around procedure and a new approach may only be performed when the appropriate action is accomplished and malfunction consequences properly evaluated.

ENGINE FAILURE DURING FINAL APPROACH

If an engine failure occurs during final approach it will be the captain's responsibility to decide to continue the approach or initiate a go around. In case of any doubt that the landing can be conducted safely, a go around must be accomplished.

3-35-01	Page 12	Code 01
---------	------------	------------

PRECISION PROCEDURES

If a complete arrival procedure to the localizer and glide slope capture point is intended, the initial approach phase may be completed using LNAV and appropriate vertical mode. Ensure the FLIGHT PLAN (FPL) pages sequence, altitude restrictions and the MAP DISPLAY reflects the air traffic clearance.

Last minute air traffic changes or constraints may be managed by appropriate use of the HDG mode, ALT mode and FLC or VS for vertical mode. Updating the FMS sequencing should be accomplished only as time permits.

Both pilots should avoid “heads-down” during the approach. Under radar vectors to intercept the localizer, select the ACT VECTORS within 30 NM from the destination airport (available only at FMS 6.1).

User: aherrera - Printed By myTechCare - Aug 09/22 - 14:17:22

ACTIONS AND CALLOUTS

DESCENT AND PRECISION APPROACH ACTIONS AND CALLOUTS		
	PF	PM
Prior to start descent	<ul style="list-style-type: none"> - Performs approach briefing (airplane status, fuel, NOTAMs, weather, MORA/MEA/MSA, basic statement for CAT I, work distribution and taxi-in route). - Sets and crosschecks the following items as required for the approach type: <ul style="list-style-type: none"> - NAV approach frequencies; - Approach course. - Checks approach speeds. <p>"DESCENT CHECKLIST".</p>	<ul style="list-style-type: none"> - Calculates approach speeds. - Sets and crosschecks the following items as required for the approach type: <ul style="list-style-type: none"> - NAV approach frequencies; - Approach course. - Checks approach speeds. - Pushes in Windshield Heating Buttons and checks/sets the airport elevation at the Pressurization Panel. <p>"DESCENT CHECKLIST COMPLETED".</p>

NOTE: Callouts are shown in bold text.

CONTINUES ON NEXT PAGE

3-35-01	Page 14	Code 01
---------	------------	------------

REVISION 10

CONTINUED FROM PREVIOUS PAGE

DESCENT AND PRECISION APPROACH ACTIONS AND CALLOUTS		
	PF	PM
10000 ft AFE	"TEN THOUSAND CHECKED".	<p>"TEN THOUSAND".</p> <ul style="list-style-type: none"> - Selects external lights ON. - Selects No Smoking and Fasten Belts ON. - Receives a verbal confirmation from the Cabin Attendant that the airplane is SECURED for landing.
Transition Level	<ul style="list-style-type: none"> - Sets and verifies altimeters. <p style="text-align: center;">"APPROACH CHECKLIST".</p>	<p>"TRANSITION LEVEL".</p> <ul style="list-style-type: none"> - Sets and verifies altimeters. - Verifies that all altimeters are set QNH (QFE if applicable).⁽¹⁾ - Sets the Terrain on MFD below the MSA. - Verifies pre-selected final approach course, radios and DA minimums. - Performs approach checklist. <p>"APPROACH CHECKLIST COMPLETED".</p>

⁽¹⁾ VNAV is prohibited on QFE operations.

NOTE: Callouts are shown in bold text.

CONTINUES ON NEXT PAGE

SOP-145/1489

REVISION 10

3-35-01	Page 15	Code 01
---------	------------	------------

CONTINUED FROM PREVIOUS PAGE

DESCENT AND PRECISION APPROACH ACTIONS AND CALLOUTS		
	PF	PM
On heading to intercept final approach course	– Pushes the APR Button on FGC. ^{(2) (3)} "FLAPS 9" .	– Checks proper annunciation on FMA. – Select Flaps 9°.
First positive inward motion of localizer	"CHECKED" .	"LOCALIZER ALIVE" .
First positive motion of glide slope	"CHECKED" .	"GLIDE SLOPE ALIVE" .
Glide Slope 1 dot above	"LANDING GEAR DOWN, FLAPS 22" .	– Selects landing gear ..down. – Selects flaps 22°.

⁽²⁾ If not equipped with VNAV and with ILS as navigation source, GS mode is armed.

⁽³⁾ If equipped with VNAV, VGP is armed.

NOTE: Callouts are shown in bold text.

CONTINUES ON NEXT PAGE

User: aherrera - Printed By myTechCare - Aug 09/22 - 14:17:22

CONTINUED FROM PREVIOUS PAGE

DESCENT AND PRECISION APPROACH ACTIONS AND CALLOUTS		
	PF	PM
Final approach fix inbound or outer marker	"SET GO-AROUND HEADING AND ALTITUDE". "FLAPS___, BEFORE LANDING CHECKLIST".	– Sets go-around heading and altitude. – Selects landing flaps. NOTE: Performs before landing checklist. "BEFORE LANDING CHECKLIST COMPLETED".
1000 ft AFE	"CHECKED". – Verifies instruments and no flags.	"ONE THOUSAND". – Verifies instruments and no flags.
Below 1000 ft AFE	-	– Calls out deviations: – "GUIDANCE". – "SPEED". – "LOCALIZER". – "GLIDE SLOPE".
500 ft AFE	"CHECKED".	– Verifies or calls out. "FIVE HUNDRED". – Looks outside.
100 ft to minimums EGPWS callout "APPROACHING MINIMUMS"	-	-

NOTE: Callouts are shown in bold text.

CONTINUES ON NEXT PAGE

SOP-145/1489

REVISION 10

3-35-01	Page 17	Code 01
---------	------------	------------

CONTINUED FROM PREVIOUS PAGE

DESCENT AND PRECISION APPROACH ACTIONS AND CALLOUTS		
	PF	PM
At DA – If visual reference is established at an adequate position for a safe landing by LSP.	"CONTINUE" .	"VISUAL" .
At DA – If no visual reference is established or visual contact is established at an inadequate position for a safe landing.	"GO-AROUND" – Initiates go-around procedure.	-

NOTE: Callouts are shown in bold text.

ILS CAT I

When performing an ILS CAT I, use the autopilot to minimize crew workload.

When starting the deceleration segment, approaching the airport while either being radar vectored or using own navigation, slow the airplane to 180 KIAS, at base leg select flap 9 reducing to flap 9 maneuvering speed.

When cleared for the approach and airplane is established on an intercept heading of less than 90° of the inbound track, select the APR mode on the guidance controller to arm the LOC and GS and set vertical speed using SPD and or IAS selector, VS, FLC or VNAV (if available) as required to capture the glide slope.

When “Localizer Alive” is called out, be ready to use heading select or some other means to aid the autopilot in capturing the localizer without overshooting or undershooting.

Once captured, the glide slope will become active and the go-around altitude may now be set on the Guidance Panel. When one dot to intercept the glide slope, extend landing gear, select flap 22 reducing to flap 22 maneuvering speed. At outer marker capture, select landing flaps, reducing to the V_{AP} . For far ILS captures, the landing gear extension and landing flaps can be delayed, however the airplane must be configured with landing gear down and landing flaps prior to FAF or 5 NM from the threshold, whichever comes first.

If the airplane cannot meet the stabilized approach criteria, execute a missed approach.

STEEP APPROACH

The Steep Approach procedure is applicable to approaches where the angle of descent on final path for landing is greater than or equal to 5.5°. The maximum tail wind for steep approach is 5 kt.

It must be flown following the standards applicable for the type of approach Precision or Non-Precision.

The use of AP is recommended, but no restrictions apply for Steep Approaches with autopilot disengaged.

STEEP APPROACH OPERATION

The rate of descent during the steep approach will be influenced by variation of the thrust setting. The steeper the approach, the less thrust is needed. But remember, approaches with idle thrust should be avoided. When an engine is at idle, spooling it up to a high thrust condition takes far more time than when this engine is functioning above idle.

Plan to be in landing configuration before intercepting the final approach descent path because of the lower deceleration rate attainable during steep descents.

The airplane should reach Final Approach Fix configured for landing, with landing gear DOWN, FLAP 45, Steep Approach Mode ENGAGED and at V_{REF} for steep approach. The airplane must be fully stabilized on approach when it is three miles or 1000 ft from touchdown, whichever happens first.

Make sure the airplane is properly trimmed during the approach. This maximizes the authority for the flare or in the event of a missed approach.

The approach configuration with steep mode engaged provides a slight nose up pitch attitude which makes the flare maneuver almost identical to those observed during 3° approaches. Anyway, good flare-thrust coordination is essential, either on a normal or on a steep approach.

Any failure of the steep approach mode on final should lead to a go-around, unless the remainder of the approach is possible to be conducted without the steep approach capability.

ENGINE FAILURE

An engine failure above DA (MDA) should lead to a go around.

Below DA (MDA) the approach may be continued maintaining the current airplane configuration.

3-35-01	Page 20	Code 01
---------	------------	------------

STEEP APPROACHES ACTIONS AND CALLOUTS

	PF	PM
Approach Briefing	– Presses the STEEP button on pedestal panel.	– Confirms the STEEP arm annunciation on FMA.
Before final glide path interception	– In landing configuration. “BEFORE LANDING CHECK LIST” .	– Check STEEP engaged annunciation and performs the BEFORE LANDING checklist. – “BEFORE LANDING CHECKLIST COMPLETED” .

User: aherrera - Printed By myTechCare - Aug 09/22 - 14:17:22

ILS CAT II/III

In case CAT II or CAT III approach, use the same approach procedure describe in the ILS CAT I (section 3-35-01).

The selection of RA minimums on the PFD identifies that CAT II or CAT III approach is intended.

The pilots ensure correct approach mode is annunciated on the FMA, and monitors the ILS APP mode. During approach the pilot places one hand on the throttles guarding the GO-AROUND button and other hand on the control column near or adjacent to the autopilot disconnect button. At 80 ft above DH, when “Approaching Minimums” call is announced the pilot responds continuing the approach and diverts his scan to outside visual cues. When the “Minimums” automatic callout is announced, one of the following occurs:

- If the proper CAT II/III visual cues are not present, or if the airplane is not in a position which a descent to the runway can be made, the pilot selects GO-AROUND button and executes the go-around. The pilots should monitor the instruments for deviation from a normal go-around profile.
- If the proper CAT II/III visual cues are identifiable, and a descent to landing can be made at a normal descent rate which will allow touchdown within the touchdown zone, the pilot should proceed to land. Flight instruments should continuing be monitored until touchdown and any deviations from the normal descent and speed profile should be warned.

3-35-01	Page 22	Code 01
---------	------------	------------

DESCENT AND PRECISION APPROACH ACTIONS AND CALLOUTS

DESCENT AND PRECISION APPROACH – ACTIONS AND CALLOUTS		
	PF	PM
<p>Prior to start descent</p>	<ul style="list-style-type: none"> – Performs approach briefing (airplane status, fuel, NOTAMs, weather, MORA/MEA/MSA, basic statement for CAT I, work distribution and taxi-in route). – Sets and crosschecks the following items as required for the approach type: <ul style="list-style-type: none"> – NAV approach frequencies; – Approach course. – Checks approach speeds. <p>“DESCENT CHECKLIST”.</p>	<ul style="list-style-type: none"> – Calculates approach speeds. – Sets and crosschecks the following items as required for the approach type: <ul style="list-style-type: none"> – NAV approach frequencies; – Approach course. – Checks approach speeds. – Pushes in Windshield Heating Buttons and checks/sets the airport elevation at the Pressurization Panel. <p>“DESCENT CHECKLIST COMPLETED”.</p>

CONTINUES ON NEXT PAGE

CONTINUED FROM PREVIOUS PAGE

DESCENT AND PRECISION APPROACH – ACTIONS AND CALLOUTS		
	PF	PM
10000 ft AFE	“TEN THOUSAND CHECKED” .	“TEN THOUSAND” . – Selects external lights ON. – Selects No Smoking and Fasten Belts ON. Alerts cabin crew “ATTENTION CREW, PREPARE FOR LANDING” .
Transition Level	– Sets and verifies altimeters. “APPROACH CHECKLIST” .	“TRANSITION LEVEL” . – Sets and verifies altimeters. – Verifies that all altimeters are set QFE/QNH. – Sets the Terrain on MFD below the MSA. – Verifies pre-selected final approach course, radios and DA minimums. – Performs approach checklist. “APPROACH CHECKLIST COMPLETED” .
On heading to intercept final approach course	– Presses the APR on FGC “FLAPS 9” .	– Checks proper annunciation on FMA. – Select Flaps 9.

CONTINUES ON NEXT PAGE

3-35-01	Page 24	Code 01
---------	------------	------------

CONTINUED FROM PREVIOUS PAGE

DESCENT AND PRECISION APPROACH – ACTIONS AND CALLOUTS		
	PF	PM
First positive inward motion of localizer	“CHECKED”.	“LOCALIZER ALIVE”.
First positive motion of glide slope	“CHECKED”.	“GLIDE SLOPE ALIVE”.
Glide Slope 1 dot above	“LANDING GEAR DOWN, FLAPS 22”.	<ul style="list-style-type: none"> – Selects landing gear down. – Selects flaps 22°.

CONTINUES ON NEXT PAGE

User: aherrera - Printed By myTechCare - Aug 09/22 - 14:17:22

CONTINUED FROM PREVIOUS PAGE

DESCENT AND PRECISION APPROACH – ACTIONS AND CALLOUTS		
	PF	PM
Final approach fix inbound or outer marker	<p>“SET GO- AROUND HEADING AND ALTITUDE”.</p> <p>“FLAPS __, BEFORE LANDING CHECKLIST”.</p>	<p>– Sets go-around heading and altitude.</p> <p>– Selects landing flaps.</p> <p>– Performs before landing checklist.</p> <p>“BEFORE LANDING CHECKLIST COMPLETED.”</p>
1000 ft AFE	<p>“CHECKED”.</p> <p>– Verifies instruments and no flags.</p>	<p>“ONE THOUSAND”.</p> <p>– Verifies instruments and no flags.</p>
Below 1000 ft AFE	–	<p>– Callouts deviations:</p> <p>– “GUIDANCE”.</p> <p>– “SPEED”.</p> <p>– “LOCALIZER”.</p> <p>– “GLIDE SLOPE”.</p>
500 ft AFE	<p>“CHECKED”.</p>	<p>– Verifies or calls out.</p> <p>“FIVE HUNDRED”.</p> <p>– Looks outside.</p>
100 ft to minimums EGPWS callout “APPROACHING MINIMUMS”	–	–

CONTINUES ON NEXT PAGE

3-35-01	Page 26	Code 01
---------	------------	------------

REVISION 10

User: aherrera - Printed By myTechCare - Aug 09/22 - 14:17:22

CONTINUED FROM PREVIOUS PAGE

DESCENT AND PRECISION APPROACH – ACTIONS AND CALLOUTS		
	PF	PM
<p>At DA: If visual reference is established at an adequate position for a safe landing by LSP.</p>	“CONTINUE” .	“VISUAL” .
<p>At DA: If no visual reference is established or visual contact is established at an inadequate position for a safe landing.</p>	<p>“GO-AROUND”. – Initiates go-around procedure.</p>	–

- NOTE:** - Callouts are shown in bold text.
 - Runway approach lights could be considered as a visual cue.

User: aherrera - Printed By myTechCare - Aug 09/22 - 14:17:22

INTERCEPTING GLIDESLOPE FROM ABOVE

Several different situations, such as ATC restriction, may lead to a glideslope interception from above. Pilots should avoid situations that could lead to intercepting the glideslope from above. If that happens, the pilots must take the appropriate actions to guarantee a stabilized approach. If the stabilized approach criteria are not met, the PF must initiate a Go Around. The approach must be stable before reaching 1000 ft AGL (IMC), 500 ft (VMC), or other altitude in accordance with company policies.

When flying to intercept the glideslope the pilots should:

- Monitor all the parameters of a stabilized approach and callout any deviation. At pilot's discretion, lower the landing gear to avoid an excessive increase on speed;
- Confirm that the glideslope vertical mode is armed, GS white on the FMA;
- Use Vertical Speed (VS) vertical modes to intercept the glideslope;
- Monitor the glideslope deviation and the engagement of GS mode (GS green of FMA) when the glideslope is captured.

Once the airplane captures the glideslope, the crew must crosscheck if the airplane captured the correct glideslope signal. Due to the design of ILS system, it may generate false glideslope signals above the actual glideslope signal.

Pilots can use the information on the published approach procedure to crosscheck the vertical speed and the distance to the runway with altitude of the airplane during approach.

The capture of a false glideslope signal may result in any of the following abnormalities:

- Glide path angles steeper than the glide path angle of the published approach procedure;
- Abnormal rate of descent;
- Abnormal altitude – distance relationship; and

3-35-01	Page 28	Code 01
---------	------------	------------

- Abnormal behavior of the autopilot if autopilot is in use during the approach.

If a false glideslope capture is suspected, Initiated a Go Around.

User: aherrera - Printed By myTechCare - Aug 09/22 - 14:17:22

INTENTIONALLY BLANK

User: aherrera - Printed By myTechCare - Aug 09/22 - 14:17:22

3-35-01	Page 30	Code 01
---------	------------	------------

Copyright © by Embraer. Refer to cover page for details.

REVISION 10

SOP-145/1489

LOW VISIBILITY APPROACH

The knowledge of approach lighting systems and regulations, and how they apply to the required visual references is essential to perform safe and successful approaches during low visibility conditions.

A review of the approach and runway lighting systems available during the approach briefing is recommended as the pilot has only a few seconds to identify the lights required to continue the approach.

For all low visibility approaches, a review of the airport diagram, expected runway exit, runway remaining lighting and expected taxi route during the approach briefing is recommended.

BASIC STATEMENTS

- Successful low visibility approach requires crew coordination.
- Any doubt about the approach's success must lead to a go around.
- Observe strict adherence to standard call-out procedures since they are vital to a successful approach.
- The pilot should guard the controls and the throttles throughout all phases of the automatic approach, landing and rollout and be prepared to manually land or initiate a go around any time it is considered necessary.
- Use of the external lights while in IMC:
 - Strobe lights may cause disorientation;
 - Landing lights at night and/or during precipitation could reduce the capability to acquire visual references.
- The external lights may be turned off and as soon as visual contact is assured, the pilot turns ON the external lights.
- It is recommended to adjust the cockpit overall illumination to the minimum necessary.
- Adjust seat according to the visual reference located at the central column of the windshield.

User: aherrera - Printed By myTechCare - Aug 09/22 - 14:17:22

WORK DISTRIBUTION

The pilot is responsible for monitoring all phases of the low visibility approach remaining on instruments and calls out any observed discrepancies:

Deviation	Callout
Guidance Cue becomes half circle excursion out of Flight Path Vector (HGS) or any deviation from Flight Director.	“GUIDANCE”
Rate of descent more than 900 ft/min.	“SINK RATE”
Localizer and/or Glide Slope deviation greater than 1 dot.	“LOC”/“GLIDE”
Above Target speed + 10 kt.	“SPEED”
Below Target speed – 5 kt; or any speed less than V_{RF} , whichever is higher.	
Bank angle in excess of 25°.	“BANK”
Pitch angle below - 5° or above 5° in relation to the established pitch.	“PITCH”
Any Autopilot or Flight Director malfunction.	Calls the failure
EGPWS callouts not performed automatically.	Perform the expected callouts

User: aherrera - Printed By myTechCare - Aug 09/22 - 14:17:22

GO AROUND

- PILOT must immediately initiate a Go Around at minimums if:
 - Not enough visual guidance is available.
 - Visual guidance is obtained but the airplane's position is inadequate for a safe landing.

MALFUNCTIONS

- Any airplane malfunction requiring crew action below 1000 ft AFE under IMC should lead to a go around.
- Malfunctions above 1000 ft AFE are to be evaluated by the crew and should lead to a go around if necessary procedures can not be completed before reaching 1000 ft.

- NOTE:** - In case of any failure that affects the flight director approach mode capability or the ability to continue on the same approach category above 1000 ft AFE, the decision to continue on a downgraded approach category must be made if the missed approach considerations and the new approach minimums have been set at or above 500 ft AFE, and no other checklists or procedures are required below 1000 ft.
- In case of go-around follow the normal go-around procedure and a new approach may only be performed when the appropriate action is accomplished and malfunction consequences properly evaluated.

**LOW VISIBILITY APPROACH ACTIONS AND
CALLOUTS**

ACTIONS AND CALLOUTS DESCENT		
	PF	PM
<p>Prior to start descent</p>	<ul style="list-style-type: none"> - Performs approach briefing (airplane status, fuel, NOTAMS, weather, MORA/MEA/MSA, basic statement for low visibility approach, work distribution and taxi-in route). - Performs RA test. - Sets DH minimums. - Sets NAV approach frequencies. ⁽¹⁾ - Sets approach course. ⁽²⁾ - Checks approach speeds. <p>“DESCENT CHECKLIST”.</p>	<ul style="list-style-type: none"> - Calculates and sets approach speeds. - Performs RA test. - Sets DH minimums. - Sets NAV approach frequencies. ⁽¹⁾ - Sets approach course. ⁽²⁾ - Checks approach speeds. - Pushes in Windshield Heating Buttons and checks/sets the airport elevation at the Pressurization Panel. - “DESCENT CHECKLIST COMPLETED”.

NOTE: ⁽¹⁾ Both receivers must be on the same frequency.
⁽²⁾ Both approach courses must be on the same course.

CONTINUES ON NEXT PAGE

3-35-05	Page 4	Code 01
---------	-----------	------------

REVISION 4

CONTINUED FROM PREVIOUS PAGE

ACTIONS AND CALLOUTS DESCENT		
	PF	PM
10000 ft AFE	“TEN THOUSAND CHECKED” .	“TEN THOUSAND” . – Selects external lights ON. – Selects NO SMOKING and FSTN BELTS ON. – Alerts cabin crew. “ATTENTION CREW, PREPARE FOR LANDING” .
Transition Level	– Sets altimeters to QNH and checks. – Verifies pre-selected final approach course, radio NAVS and RA minimums. “APPROACH CHECKLIST” .	“TRANSITION LEVEL” . – Sets altimeter to QFE/QNH. – Sets the Terrain on MFD below the MSA. – Verifies pre-selected final approach course, radio NAVS and RA minimums. – Performs approach checklist. “APPROACH CHECKLIST COMPLETED” .

CONTINUES ON NEXT PAGE

CONTINUED FROM PREVIOUS PAGE

ACTIONS AND CALLOUTS APPROACH		
	PF	PM
On heading to intercept final approach course	– Presses APR button on FGC. “FLAPS 9” .	– Selects Flaps 9.
First positive inward motion of localizer	“CHECKED” .	“LOCALIZER ALIVE” .
First positive motion of glide slope	“CHECKED” .	“GLIDE SLOPE ALIVE” .
Glide Slope 1 dot above	“LANDING GEAR DOWN FLAPS 22” .	– Selects landing gear down. – Selects Flaps 22.
At Glide Slope	“SET GO AROUND HEADING AND ALTITUDE” .	“SET _____ (1)” . – Selects the go around altitude.

NOTE: ⁽¹⁾ Go around heading and altitude. For example: **“SET 240° 5000 ft”**.

CONTINUES ON NEXT PAGE

CONTINUED FROM PREVIOUS PAGE

ACTIONS AND CALLOUTS APPROACH		
	PF	PM
<p>Between 1500 ft and 1000 ft RA or 2 NM from outer marker, whichever comes first</p>	<p>“BEFORE LANDING CHECKLIST”. – Checks the CAT 2 label on PFD. “CAT 2 ENGAGED”.</p>	<p>– Performs the Before Landing checklist and calls out. “BEFORE LANDING CHECKLIST COMPLETED”. “CHECKED”.</p>
<p>At 1000 ft AFE</p>	<p>“CHECKED”. – Verifies instruments and no flags displayed.</p>	<p>“ONE THOUSAND”. – Verifies instruments and no flags displayed.</p>
<p>Below 1000 ft AFE</p>	<p>–</p>	<p>– Calls out any deviations: “SPEED”. “LOCALIZER”. “GLIDE SLOPE”. “GUIDANCE”. ⁽¹⁾ “SINK RATE”.</p>

NOTE: ⁽¹⁾ For HGS All approaches.

CONTINUES ON NEXT PAGE

CONTINUED FROM PREVIOUS PAGE

ACTIONS AND CALLOUTS APPROACH		
	PF	PM
At 500 ft AFE ⁽²⁾ , EGPWS callout: “FIVE HUNDRED”	“CHECKED” .	– Verifies or calls out. “FIVE HUNDRED” .
100 ft above Minimums EGPWS callout: “APPROACHING MINIMUMS”	– Starts looking for visual cues. ⁽¹⁾	– Verifies or calls out. “APPROACHING MINIMUMS” .
At DH (EGPWS callout “MINIMUMS”) – If visual reference is established and adequate position for a safe landing exists	“CONTINUE” .	– Verifies or calls out. “MINIMUMS” .

NOTE: - ⁽¹⁾ On a NO AUTOPILOT NO HGS approach the PM starts scanning outside looking for visual cues, when visual reference is established calls out **“VISUAL”**. The PF should keep scanning the flight instruments and look outside when receive the callout **“VISUAL”**. When reaching the MINIMA altitude with no callout from the PM, PF should callout **“MINIMUMS, GO AROUND”**.

- ⁽²⁾ Operator’s policy may standardize 500 ft above airport elevation due terrain area on final approach.
- Runway approach lights could be considered as a visual cue.

CONTINUES ON NEXT PAGE

CONTINUED FROM PREVIOUS PAGE

ACTIONS AND CALLOUTS APPROACH		
	PF	PM
At DH (EGPWS callout “MINIMUMS, MINIMUMS”) – If no visual reference is established and/or an inadequate position for a safe landing exists	<p style="text-align: center;">“GO AROUND”.</p> – Initiates go around procedure.	– Verifies or calls out. “MINIMUMS” .

NOTE: Callouts are shown in bold text.

User: aherrera - Printed By myTechCare - Aug 09/22 - 14:17:22

User: aherrera - Printed By myTechCare - Aug 09/22 - 14:17:22

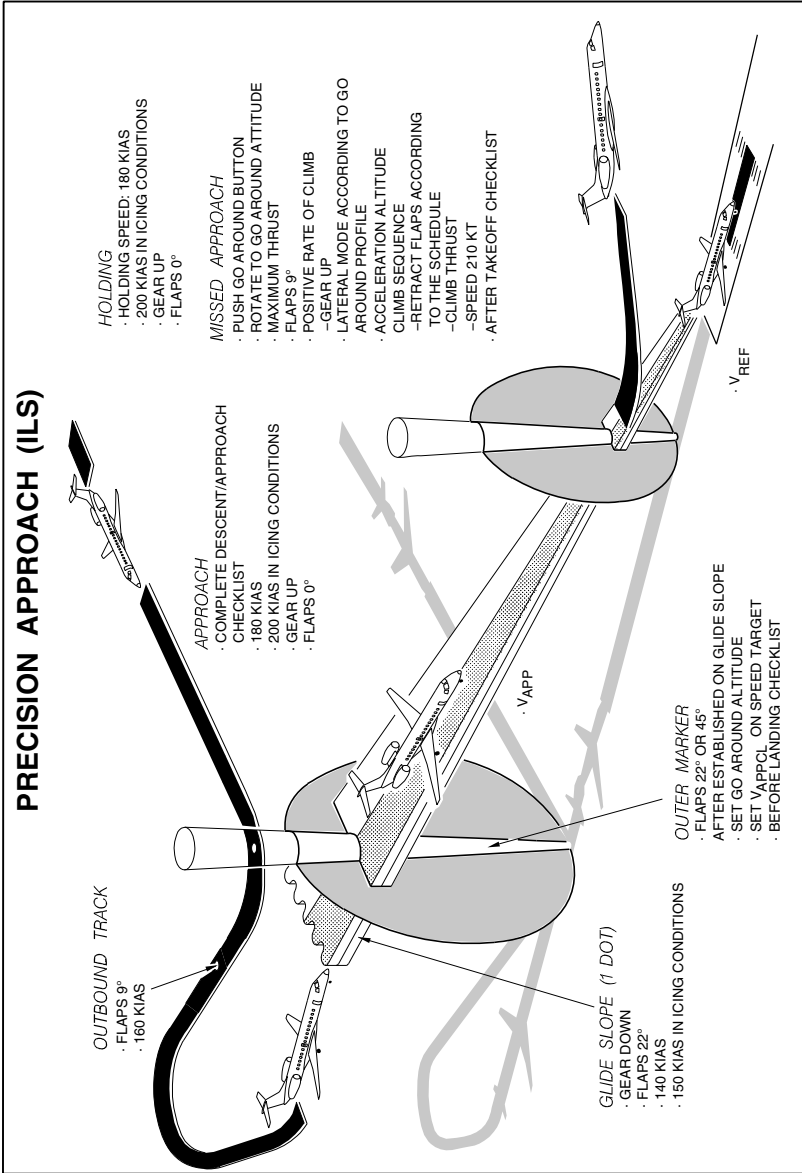

EM145AOM021003B.DGN

3-35-05	Page 10	Code 01
---------	------------	------------

Copyright © by Embraer. Refer to cover page for details.

REVISION 4

SOP-145/1489

ONE ENGINE INOPERATIVE PRECISION APPROACH

In case of engine failure on approach, use the procedure describe in the ILS approach section, on this chapter.

APPROACH PREPARATION

- Plan to be stabilized on final in landing configuration at about 8 NM, before 1000 ft;
- Pilot should maintain the directional control using the rudder pedals and trim;
- When stabilized and on short final, set the rudder trim to neutral.
- Wind and gust correction on V_{APP} should be applied normally, except that the minimum wind additive is zero.

ONE ENGINE INOPERATIVE PRECISION APPROACH (ILS)

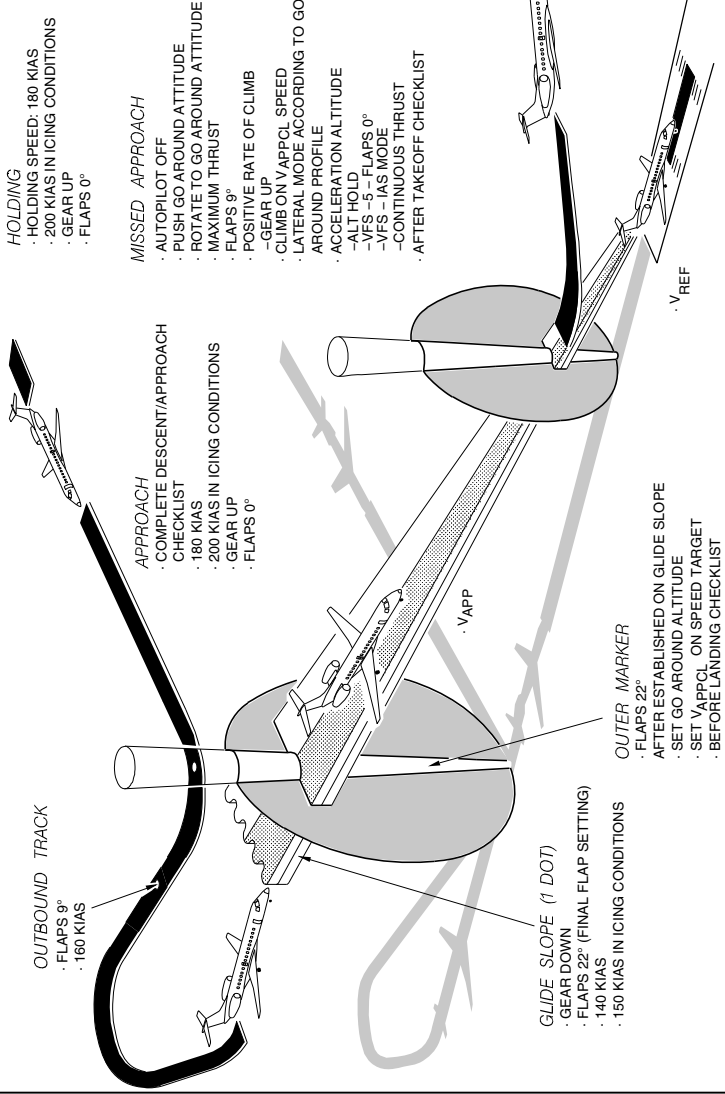

- HOLDING**
- HOLDING SPEED: 180 KIAS
 - 200 KIAS IN ICING CONDITIONS
 - GEAR UP
 - FLAPS 0°

- MISSED APPROACH**
- AUTOPILOT OFF
 - PUSH GO AROUND ATTITUDE
 - ROTATE TO GO AROUND ATTITUDE
 - MAXIMUM THRUST
 - FLAPS 9°
 - POSITIVE RATE OF CLIMB
 - GEAR UP
 - CLIMB ON V APPCL SPEED
 - LATERAL MODE ACCORDING TO GO AROUND PROFILE
 - ACCELERATION ALTITUDE
 - ALT HOLD
 - VFS - 5 - FLAPS 0°
 - VFS - IAS MODE
 - CONTINUOUS THRUST
 - AFTER TAKEOFF CHECKLIST

- APPROACH**
- COMPLETE DESCENT/APPROACH CHECKLIST
 - 180 KIAS
 - 200 KIAS IN ICING CONDITIONS
 - GEAR UP
 - FLAPS 0°

- GLIDE SLOPE (1 DOT)**
- GEAR DOWN
 - FLAPS 22° (FINAL FLAP SETTING)
 - 140 KIAS
 - 150 KIAS IN ICING CONDITIONS

- OUTER MARKER**
- FLAPS 22°
 - AFTER ESTABLISHED ON GLIDE SLOPE
 - SET GO AROUND ALTITUDE
 - SET V APPCL ON SPEED TARGET
 - BEFORE LANDING CHECKLIST

EM145AOM020143A.DGN

3-35-05	Page 12	Code 01
---------	------------	------------

REVISION 4

NON PRECISION PROCEDURES

The traditionally non-precision approaches were flown as a series of descending steps conforming to the minimum published altitudes. This technique causes the airplane's descent more difficult to manage due to changes in airspeed, rate of descent and configuration, which increases the workload and contributes to reduced situational awareness.

The use of Continuous Descent Final Approach (CDFA) technique contributes to a stabilized approach, improves fuel efficiency, reduces noise levels and reduces the probability of infringement of the required obstacle clearance during the final approach segment.

The following conditions should be considered when applying the Non-Precision approach CDFA technique:

- The go-around should be initiated at an altitude above the MDA (sometimes considered as Derived Decision altitude) to ensure the airplane does not descend below the published MDA;
- In case local authorities do not allow the Derived Decision altitude, ensure the airplane does not descend below the MDA by setting the published MDA in the altitude select.
- Some regulators consider the MDA as DA or approve the operator to use it likewise. However, it is operator's responsibility to verify if it is required to add-on some margin to it. A reasonable margin to add on the MDA is 50 ft, but a different value may be required by the local authority. The use of MDA as a DA may not ensure the required obstacle clearance.

The procedures presented herein are applicable to VOR, VOR/DME, NDB, NDB/DME, GPS only, RNAV, and RNP approaches. Non Precision Approaches may be flown using the FMS as the primary navigation source. On a non-precision approach, the use of VGP is recommended when descending on the final approach path.

Use of the autopilot reduces crew workload and allows more time for approach management and monitoring. The correct use of the altitude selector can help prevent descents below authorized altitudes.

Fly the intermediate approach conventionally, using HDG or LNAV mode.

Start the deceleration segment approaching the airport in radar vectors or using own navigation. Plan to have flaps 9 on the outbound track.

When turning for the approach and on an intercept heading of less than 90° of the inbound track, arm the LNAV mode or use the HDG mode, once on final inbound course before FAF (2 NM), extend landing gear and select flap 22. At FAF, select landing flaps, reduce to VAPP. If the aircraft cannot meet the stabilized approach criteria, execute a missed approach.

FMS AS PRIMARY SOURCE

The FMS supports the following non-precision approach types: GPS only, RNAV, VOR, VOR/DME, NDB and NDB/DME.

► *Flight Management System (FMS) version 6.1.1*

The FMS supports the following non-precision approach types: GPS only, RNAV, VOR, VOR/DME, NDB, NDB/DME, LPV and RNP AR. ◀

Final approach segment of ILS, LOC, LOC-BC, LNAV, VNAV, Visual, and Radar final approaches using the FMS as the navigation source for guidance is prohibited.

The FMS must be operated as at least a single system, with a minimum of one PFD and one MFD operational prior to commencing the approach. The signal of the station(s) that defines the approach and on board equipment must be verified operational prior to commencing the approach.

If required by local regulations to maintain a raw data crosscheck throughout the procedure both pilots must select the bearing pointer and radio frequency to the station where the procedure is based.

FMS DATABASE

The procedure to be flown must be retrieved from the FMS database and a thorough verification of all waypoints, tracks, distances, glide path angles, altitude constraints and threshold crossing altitudes must be enforced and should be addressed on approach briefings.

3-35-10	Page 2	Code 01
---------	-----------	------------

VECTORS TO FINAL

When on vectors to a final approach to be flown using the FMS as a primary source of navigation the following recommendation applies:

- Use HDG lateral mode and VS vertical mode until clear to intercept the final approach course;
- On downwind leg it is recommended to use the FMS to extend the final approach presentation;
- Arm LNAV mode through the APR or NAV button only when on the last heading to intercept the final approach course.

VNAV APPROACH

The vertical guidance when flying based on FMS is the VNAV. FMS allows Speed Intervention on ACTIVE FLT PLAN page. The VNAV possible modes to fly a non-precision approach are VPATH and VGP.

The TEMP COMP function compensates the approach, approach transitions, and missed approach altitudes constraints from the FMS navigation database according to the destination temperature inserted on the LANDING page.

NOTE: - Make sure that the temperature input is correct. Incorrect temperature input creates altitude errors which may result in incorrect values for MDA/DA and may reduce terrain clearance.

- Prior to applying temperature compensation, the flight crew must coordinate its use with ATC. A failure to do so could result in a loss of vertical separation with other traffic.

Crew is able to calculate a compensated MDA/DA on the last page in the string of the TEMP COMP pages. Once the compensated MDA/DA is inserted, it must be used as a current MDA/DA.

NOTE: Temperature compensation to MDA/DA may be subjected to local regulation.

DURING COLD WEATHER OPERATIONS

A compensated MDA (DA) is assigned on the TEMP COMP page and must be used as current MDA (DA).

VPATH

With VPATH mode engaged, set the altitude selector to MDA for continuous VNAV descent.

REVISION 10

3-35-10	Page 3	Code 01
---------	-----------	------------

With VPATH mode engaged it is not possible to set the missed approach altitude before reaching the leveled MDA. It is necessary to be at VALT mode to set the missed approach altitude. If VALT mode is not engaged, the airplane stops the descent, changes the vertical mode from VPATH to VFLCH and starts to climb to the missed approach altitude while adding thrust power on the final approach.

VGP

Whenever the VGP mode is available, fly all non-precision approaches in VGP mode.

Perform the approach conventionally and configure the airplane in a similar manner to an ILS approach.

On the heading to intercept the final approach track pressing the APP button on the guidance panel arms the VGP mode. If preview function is not presented and flying HDG mode, pressing APP button also arms LNAV mode.

Intercepting the final approach descent path engages the VGP mode. From this point, the altitude selector can be set to the missed approach altitude.

If it is the case the go-around is to be initiated from the glide path at Decision Altitude rather than in a leveled MDA.

Pilots fly the VGP as if they were in a GS. Go around at the DA or in the MDA+margin (depending on local authority). A reasonable value for this value is 50 ft.

If a holding pattern is performed, VGP engages if the active waypoint is the FAF or along track distance to the FAF is less than 2 NM. The airplane, when holding, must be established on the inbound course to the FAF.

VGP permits a glide path capture when the airplane is above the desired GP if the vertical mode is ALT. This condition may cause excessive descent angles, which may lead to destabilized approaches. This specially occurs when the engagement of the VGP is close to the FAF.

For all other vertical modes, the VGP behaves like an ILS and captures the glide path only within a certain frame (about 100 ft above or below path).

3-35-10	Page 4	Code 01
---------	-----------	------------

NOTE: - There are certain approach plates where the termination waypoint is disconnected from the runway. In this case, the VGP disengages after passing the last coded waypoint in the MS database. Alternatively, another vertical mode may be used to continue the approach.

- Although the recommend VNAV mode to fly a non-precision approach is VGP, if flying with VPATH, set the altitude selector to MDA for continuous VNAV descent.

LOC ONLY APPROACH

On LOC only approach when cleared to intercept the localizer, the transition from modes LNAV must be as follows:

- Select an appropriate vertical mode;
- Select HDG mode;
- Arm LOC mode pressing NAV mode on the Guidance panel.

**DESCENT and NON-PRECISION APPROACH ACTIONS AND
CALLOUTS**

DESCENT AND NON-PRECISION APPROACH – ACTIONS AND CALLOUTS		
	PF	PM
Prior to start descent	<ul style="list-style-type: none"> – Performs approach briefing (airplane status, fuel, NOTAMs, weather, MORA/MEA/MSA, basic statements, work distribution and taxi-in route). – Sets and crosschecks the following items as required for the approach type: <ul style="list-style-type: none"> – MDA or DA/DDA (CDFA); – NAV approach frequencies; – Approach course. – Checks approach speeds. <p>“DESCENT CHECKLIST”.</p>	<ul style="list-style-type: none"> – Calculates approach speeds. – Sets and crosschecks the following items as required for the approach type: <ul style="list-style-type: none"> – MDA or DA/DDA (CFDA); – NAV approach frequencies; – Approach course. – Checks approach speeds. – Pushes in Windshield Heating Buttons and checks/sets the airport elevation at the Pressurization Panel. <p>“DESCENT CHECKLIST COMPLETED”.</p>

CONTINUES ON NEXT PAGE

3-35-10	Page 6	Code 01
---------	-----------	------------

REVISION 10

CONTINUED FROM PREVIOUS PAGE

DESCENT AND NON-PRECISION APPROACH – ACTIONS AND CALLOUTS		
	PF	PM
10000 ft AFE	“TEN THOUSAND CHECKED” .	“TEN THOUSAND” . – Selects external lights ON. – Selects No Smoking and Fasten Belts ON. Alerts cabin crew “ATTENTION CREW, PREPARE FOR LANDING” .
Transition level	– Sets and verifies altimeters. “APPROACH CHECKLIST” .	“TRANSITION LEVEL” . – Sets and verifies altimeters. – Verifies that all altimeters are set QFE/QNH. ⁽¹⁾ – Sets the Terrain on MFD below the MSA. – Verifies pre-selected final approach course, radios and MDA. – Performs approach checklist. “APPROACH CHECKLIST COMPLETED” .

(1) VNAV is prohibited on QFE operations.

CONTINUES ON NEXT PAGE

CONTINUED FROM PREVIOUS PAGE

DESCENT AND NON-PRECISION APPROACH – ACTIONS AND CALLOUTS		
	PF	PM
If VGP is available ⁽²⁾	– Pushes APP Button on FGC. ^{(3) (4)}	-
On Outbound Track	– Verifies proper annunciation on FMA.	
	"FLAPS 9" .	– Selects Flaps 9°.
First positive inward motion of radial (Final approach course)	-	"Course is ALIVE" .
On final inbound before FAF	"LANDING GEAR DOWN, FLAPS 22" .	– Selects landing gear down. – Selects flaps 22°.

⁽²⁾ VGP is recommended for GPS and RNAV.

⁽³⁾ VGP is only available with VNAV.

⁽⁴⁾ If equipped with VNAV, VGP is armed.

CONTINUES ON NEXT PAGE

CONTINUED FROM PREVIOUS PAGE

DESCENT AND NON-PRECISION APPROACH – ACTIONS AND CALLOUTS		
	PF	PM
At FAF	<ul style="list-style-type: none"> – Starts timer (if applicable). “SET MDA⁽¹⁾”. – Verifies altimeters, instruments and no flags. 	<p>“FINAL APPROACH FIX”.</p> <ul style="list-style-type: none"> – Starts timer (if applicable). – Sets MDA⁽¹⁾. – Verifies altimeters, instruments and no flags.⁽²⁾
Between FAF and 1000 ft AFE if IMC or 500 ft if VMC	<p>“FLAPS __, BEFORE LANDING CHECKLIST”.</p>	<ul style="list-style-type: none"> – Selects landing flaps. – Performs the before landing checklist. “BEFORE LANDING CHECKLIST COMPLETED”.
1000 ft AFE	<ul style="list-style-type: none"> – Verifies instruments and no flags. 	<p>“ONE THOUSAND”.</p> <ul style="list-style-type: none"> – Verifies instruments and no flags.⁽³⁾

NOTE: - ⁽¹⁾ For CDFA, whenever established on the final approach path with a proper rate of descent, PF requests "SET GO AROUND HEADING AND ALTITUDE". Both pilots should exercise awareness that the airplane will not stop the descent and neither level off at the MDA. In case visual reference is not established at DDA/DA a go around must be initiated.

- ⁽²⁾ If during the approach the DGR annunciation appears, calls **“DEGRADED”** and proceed on the approach based on raw data or rely on visual cues, if unable, perform the missed approach procedure.

- (3) Monitor the LPV Indications throughout final approach. If the APPR annunciation is not displayed, revert to raw data or rely on visual cues. If not possible, initiate a missed approach.

CONTINUES ON NEXT PAGE

User: aherrera - Printed By myTechCare - Aug 09/22 - 14:17:22

3-35-10	Page 10	Code 01
---------	------------	------------

Copyright © by Embraer. Refer to cover page for details.

REVISION 10

SOP-145/1489

CONTINUED FROM PREVIOUS PAGE

DESCENT AND NON-PRECISION APPROACH – ACTIONS AND CALLOUTS		
	PF	PM
Below 1000 ft AFE	–	Calls out deviations: – “GUIDANCE” . – “SPEED” . – “LOCALIZER” . – “CDI” .
100 ft to minimums EGPWS callout “APPROACHING MINIMUMS”	–	–
At MDA ⁽¹⁾ or missed approach point - If visual reference is established at an adequate position for a safe landing by LSP	“LANDING” .	– When ALT mode engages, sets go- around altitude on Altitude Selector. ⁽²⁾ “VISUAL” .
At MDA ⁽¹⁾ or missed approach point - If no visual reference is established or visual contact is established at an inadequate position for a safe landing	“GO-AROUND” . – Initiates go-around procedure.	– When ALT mode engages, sets go- around altitude on Altitude Selector. ⁽²⁾

- NOTE:** - Callouts are shown in bold text.
- Runway approach lights could be considered as a visual cue.
 - ⁽¹⁾ or DDA/DA (CDFA).
 - ⁽²⁾ If applicable (Non-CDFA).

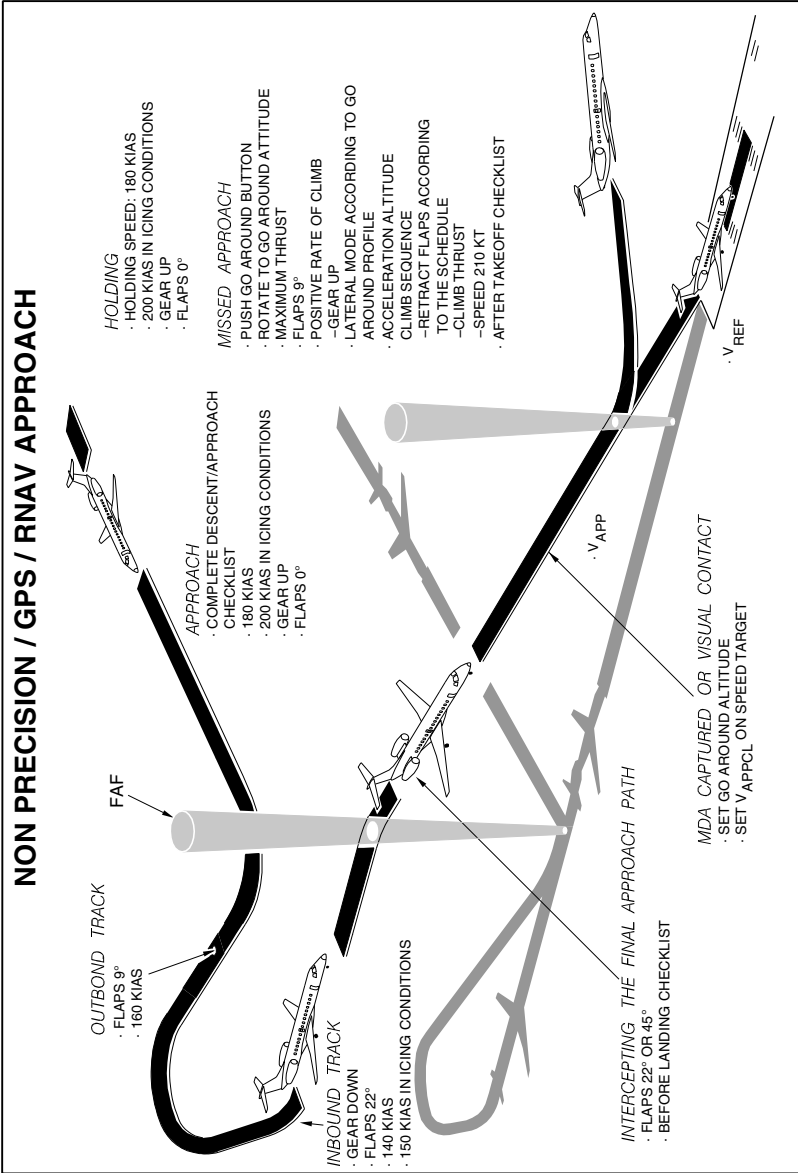

EM145AOM021004D.DGN

3-35-10	Page 12	Code 01
---------	------------	------------

REVISION 10

ONE ENGINE INOPERATIVE NON PRECISION APPROACH

In case of engine failure, use the same procedure described in the non precision approach section, in this chapter. Flap 22 should be used for landing and during approach, when stabilized and on short final, set the rudder trim to neutral.

User: aherrera - Printed By myTechCare - Aug 09/22 - 14:17:22

ONE ENGINE INOPERATIVE NON PRECISION APPROACH (VOR/NDB)

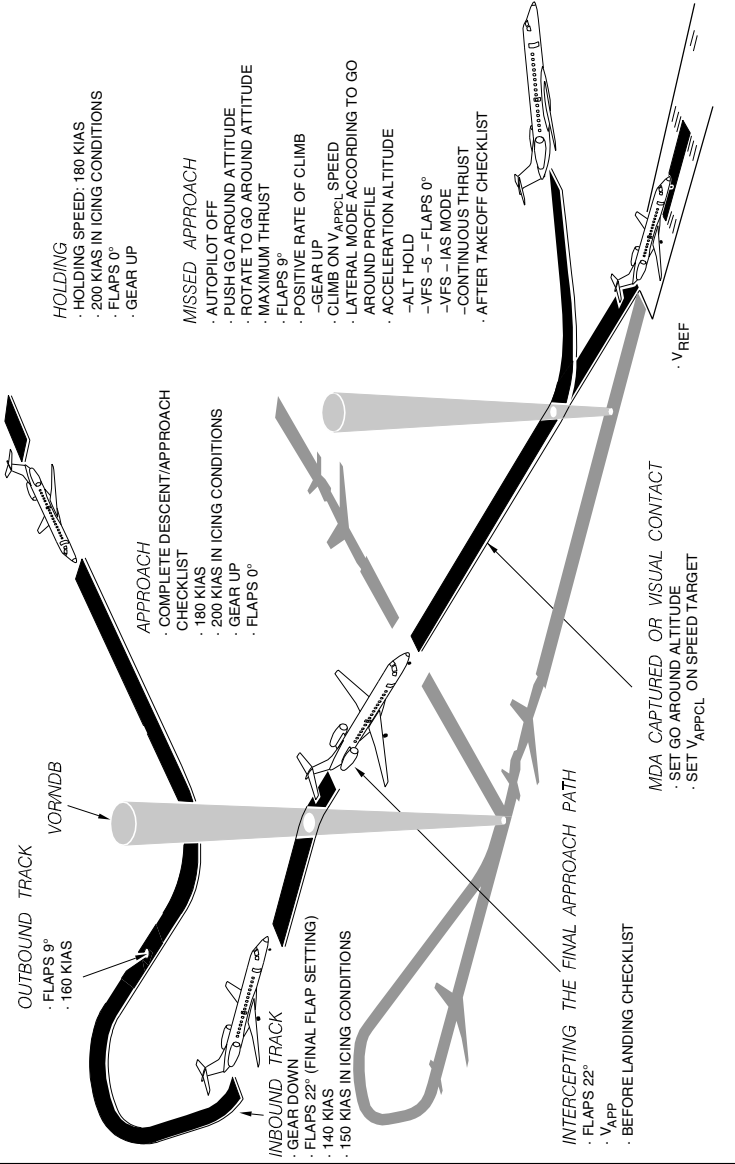

EM145AOM021014F.DGN

3-35-10	Page 14	Code 01
---------	------------	------------

CIRCLING APPROACH

A circling maneuver is a maneuver initiated by the pilot to align the aircraft with a runway for landing, when a straight-in landing from an instrument approach is not possible or is not desirable. This maneuver is initiated only, after the pilot has established visual contact with the airport.

During Circling approaches, maximum use of the autopilot should be made to minimize crew workload. Fly the approach conventionally and configure the aircraft in a similar manner to a precision or non-precision approach.

At FAF set Circling minimum on altitude selector.

Enter downwind leg using HDG mode and maintain a track parallel to the landing runway approximately 1,5 NM abeam. Maintain downwind leg configured with landing gear down, flaps 22 and 140 KIAS or 150 KIAS in icing conditions.

Turn to base leg, approximately 20 seconds after passing abeam the threshold, select landing flaps, maintain 140 KIAS, set go around altitude and perform the before landing checklist.

Prior to intercept the final approach reduce to V_{APP} .

If the airplane cannot meet the stabilized approach criteria, execute a missed approach.

User: aherrera - Printed By myTechCare - Aug 09/22 - 14:17:22

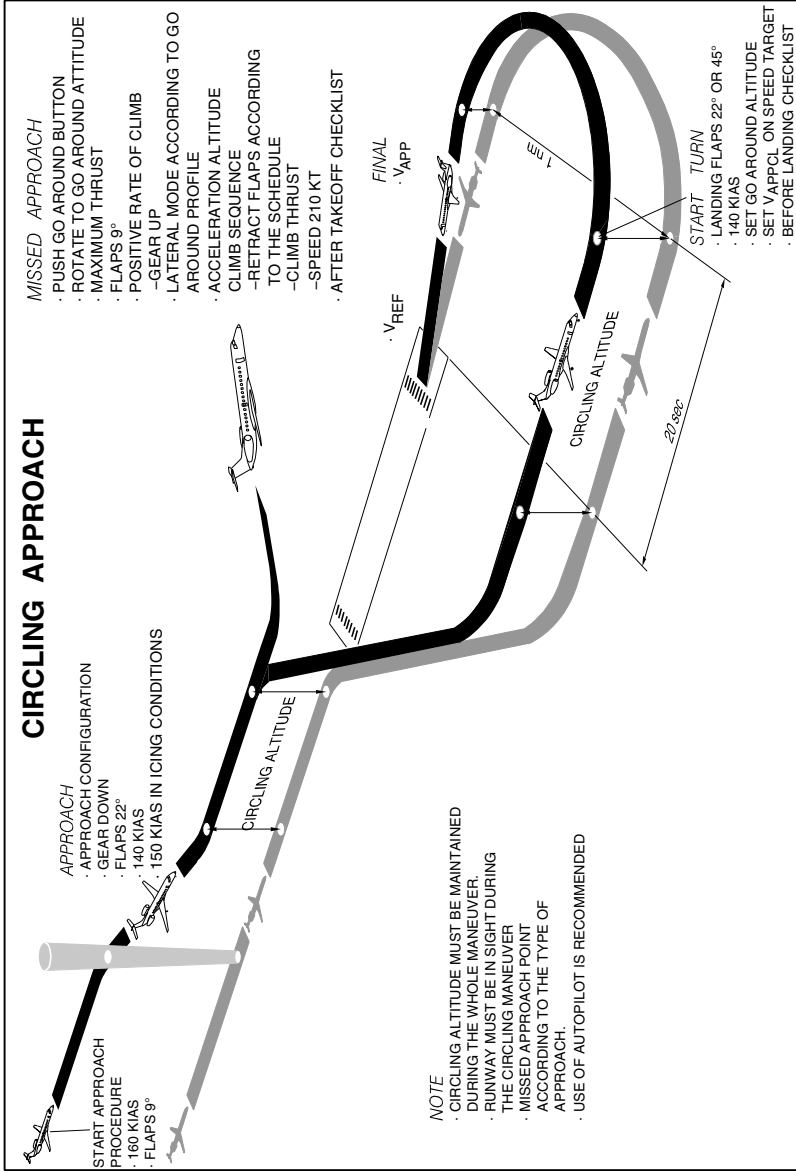

EM145AOM021005D.DGN

3-35-10	Page 16	Code 01
---------	------------	------------

Copyright © by Embraer. Refer to cover page for details.

REVISION 10

SOP-145/1489

ONE ENGINE INOPERATIVE CIRCLING APPROACH

In case of a circling approach with one engine inoperative, the same procedure for circling approach with all engines operating is to be used, with some peculiarities due to the loss of one engine.

When stabilized and on short final, set the rudder trim to neutral. If the airplane cannot meet the stabilized approach criteria, execute a missed approach.

User: aherrera - Printed By myTechCare - Aug 09/22 - 14:17:22

ONE ENGINE INOPERATIVE CIRCLING APPROACH

- MISSED APPROACH**
- AUTOPILOT OFF
 - PUSH GO AROUND ATTITUDE
 - ROTATE TO GO AROUND ATTITUDE
 - MAXIMUM THRUST
 - FLAPS 9°
 - POSITIVE RATE OF CLIMB
 - GEAR UP
 - CLIMB ON V_{APPCL} SPEED
 - LATERAL MODE ACCORDING TO GO AROUND PROFILE
 - ACCELERATION ALTITUDE
 - ALT HOLD
 - VFS -5 - FLAPS 0°
 - VFS -IAS MODE
 - CONTINUOUS THRUST
 - AFTER TAKEOFF CHECKLIST

- APPROACH CONFIGURATION**
- GEAR DOWN
 - FLAPS 22° (FINAL FLAP SETTING)
 - 140 KIAS
 - 150 KIAS IN ICING CONDITIONS

- START APPROACH PROCEDURE**
- 160 KIAS
 - FLAPS 9°

NOTE

- CIRCLING ALTITUDE MUST BE MAINTAINED DURING THE WHOLE MANEUVER.
- RUNWAY MUST BE IN SIGHT DURING THE CIRCLING MANEUVER
- MISSED APPROACH POINT ACCORDING TO THE TYPE OF APPROACH.

- START TURN**
- 140 KIAS
 - SET GO AROUND ALTITUDE
 - SET V_{APPCL} ON SPEED TARGET
 - BEFORE LANDING CHECKLIST

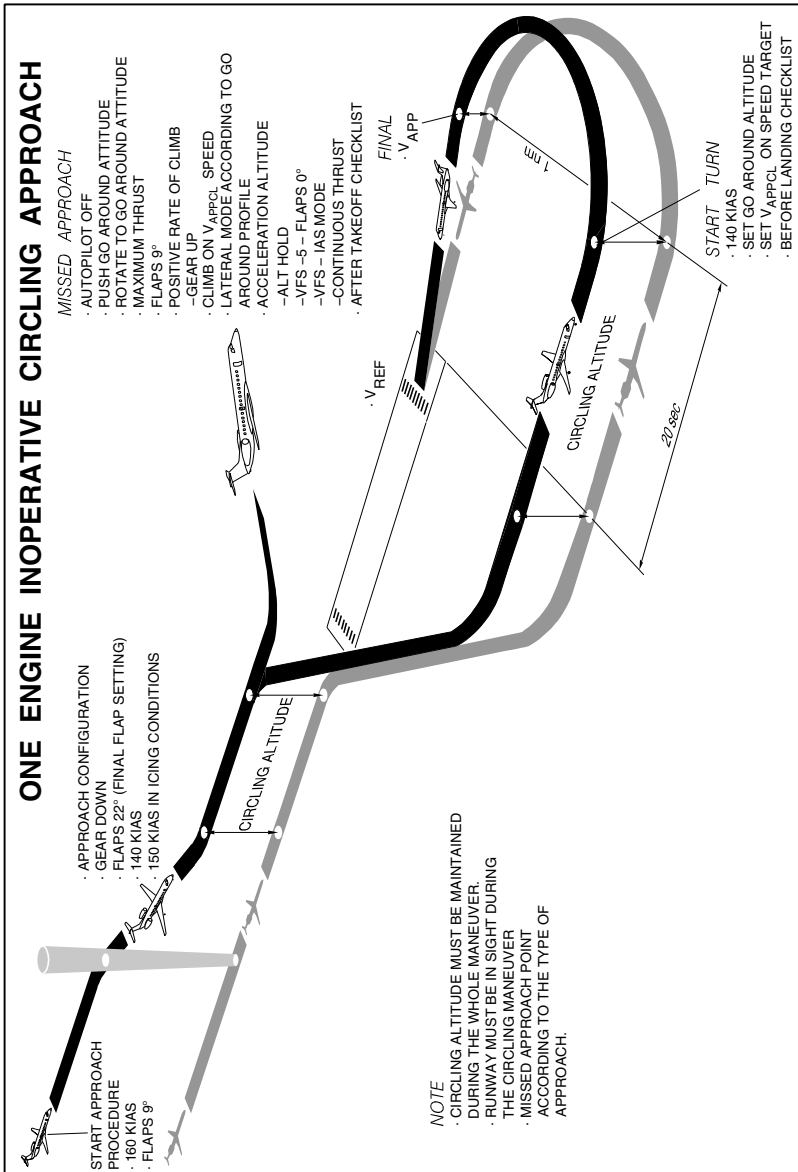

EM145AOM021015E.DGN

3-35-10	Page 18	Code 01
---------	------------	------------

VISUAL APPROACH

Perform a visual approach at an altitude of 1500 ft above the runway elevation or according to local authority regulations, enter downwind leg with flaps 9 and 160 KIAS. Maintain a track parallel to the landing runway approximately 1.5 NM abeam.

Abeam the threshold, select flaps 22, reduce speed to 140 KIAS and select gear down. Turning base leg, approximately 30 seconds after passing abeam of the threshold.

The pilot should consider the maximum bank angle of 30° while turning to base and final.

At base leg, select landing flaps reducing to V_{APP} and complete the Before Landing Checklist.

The recommended final approach path is 3°.

If the airplane cannot meet the stabilized approach criteria, execute a missed approach.

User: aherrera - Printed By myTechCare - Aug 09/22 - 14:17:22

VISUAL APPROACH (TYPICAL)

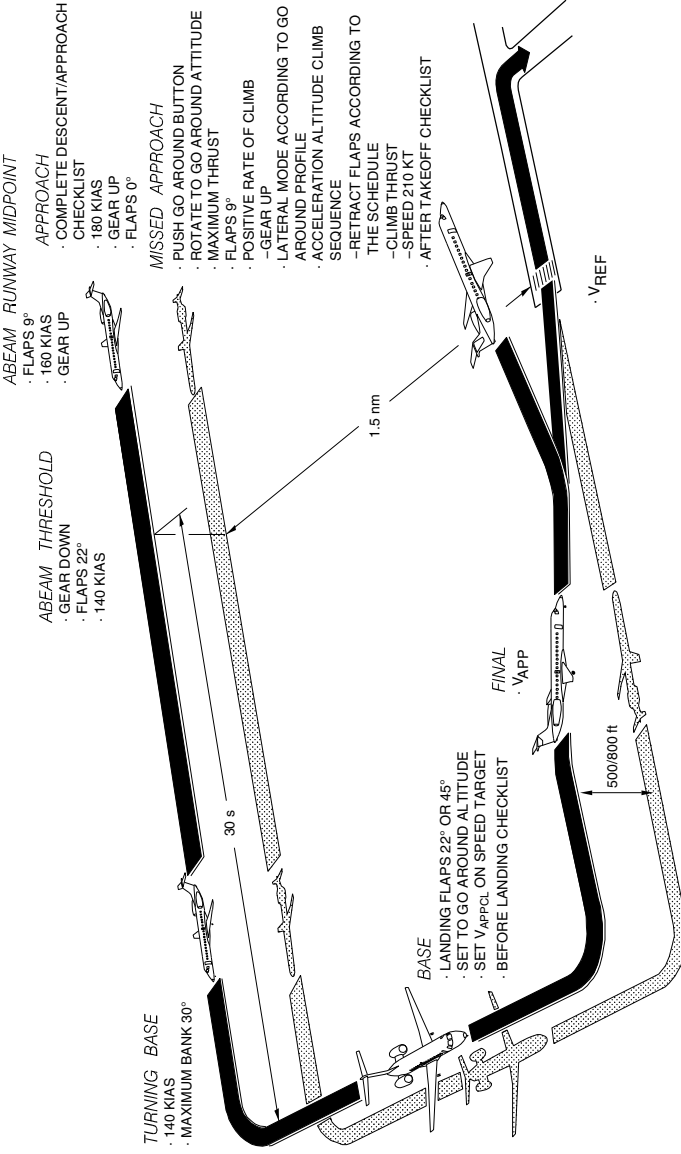

EM145AOM021012B.DGN

3-35-10	Page 20	Code 01
---------	------------	------------

ONE ENGINE INOPERATIVE VISUAL APPROACH

For engine out visual approach the pilot should accomplish all the briefings and checklist prior to entering on the traffic, set an inbound course and tune one appropriate navigation source for the landing runway as reference if available. The approach should be performed in a similar manner as in AEO visual approach except for the selection of flaps 22 as the final flap setting and the accomplishment of the before landing checklist which are made on final approach.

Abeam runway midpoint, select flaps 9 and reduce speed to 160 KIAS

Abeam the threshold, select flaps 22, reduce speed to 140 KIAS and select gear down. Turning base leg, approximately 30 seconds after passing abeam of the threshold.

The pilot should consider the maximum bank angle of 30° while turning to base and final.

At base leg, maintain flaps 22. Prior to intercept the final approach reduce to V_{APP} .

Maximum use of the autopilot should be made to minimize crew workload.

When stabilized and on short final, set the rudder trim to neutral and go-around altitude. If the airplane cannot meet the stabilized approach criteria, execute a missed approach.

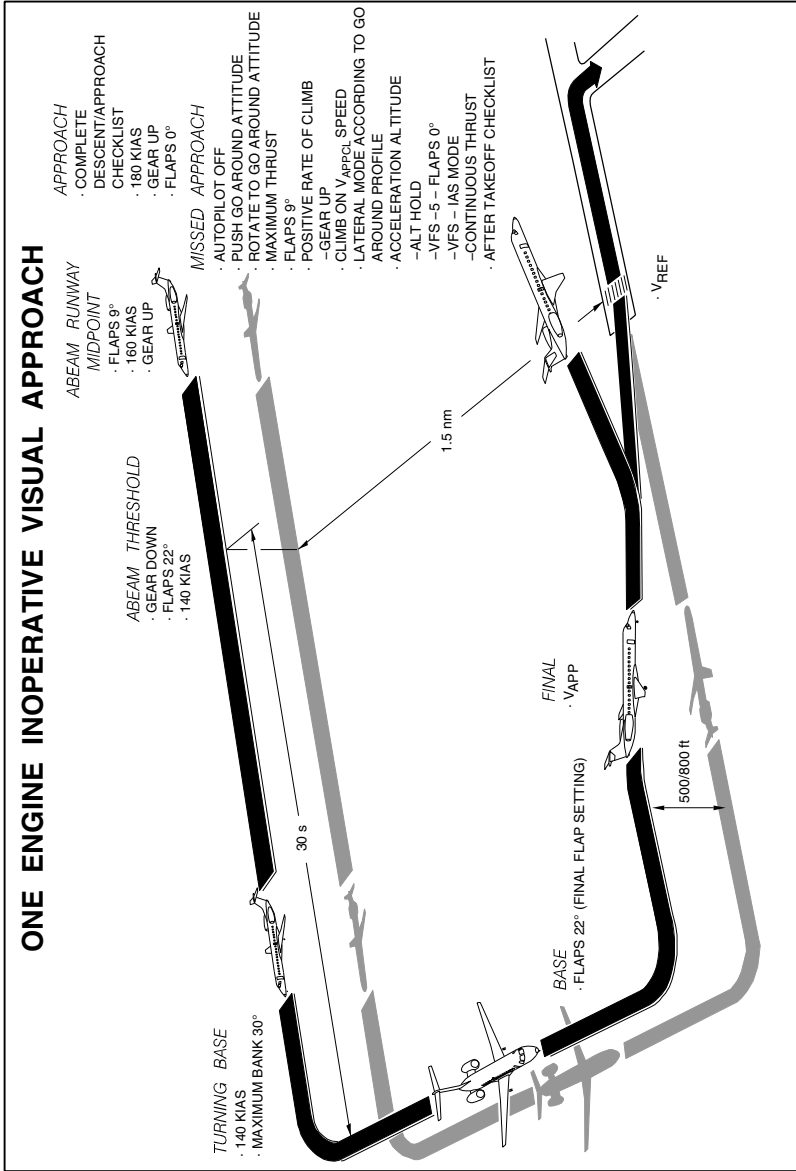

EM145AOM021013E.DGN

3-35-10	Page 22	Code 01
---------	------------	------------

GO-AROUND

No approach should be initiated unless the prevailing conditions have been understood and the crew found that landing is acceptable without undue risk. Philosophically all approaches should be treated as approaches followed by missed approaches, and landing should be treated as the alternate procedure. This mindset depends on a good approach briefing, on the knowledge of the missed approach procedure and on proper programming of the FMS.

Sufficient visual cues must exist to continue the approach below DA(DH) or MDA. If visual cues are lost due to shallow fog, snow flurries, or heavy precipitation, the pilot shall immediately initiate a go-around and fly the published missed approach procedure.

Although the PF is initially the responsible for the go-around callout, the PM may also make this callout. The flying pilot's immediate response to this callout by the PM is execution of a missed approach.

Go around, when properly executed, involve little loss of altitude below the altitude at which the go-around is "started". Conducting a missed approach when not stabilized on a final approach course should be as follows:

- If a go-around is required at any time while maneuvering in the traffic pattern and visual conditions cannot be maintained, perform a climbing turn toward the runway of intended landing.
- When over the airport and climbing, turn (in the shortest direction) to the missed approach fix and proceed with published procedure.
- To initiate the go-around press Go-Around button, moves thrust levers to MAX. Verify FMA annunciations (ROL and GA). The ROLL HOLD submode is activated when Go-Around button is pressed and disengaged when another lateral mode becomes active. The selection of another vertical mode deactivates the GA submode.
- The GA submode initially commands a go-around attitude and then transitions to speed hold mode following the GA submode logic.

NORMAL GO-AROUND – ACTIONS AND CALLOUTS

	PF	PM
Go-around	<p>“GO-AROUND”.</p> <ul style="list-style-type: none"> – Press either Go Around Button. Rotates smoothly the airplane to the FD pitch indication (GA). – Moves thrust levers to MAX. – With the airspeed greater than V_{REF}. <p>“FLAPS 9”.</p>	<ul style="list-style-type: none"> – Verify GA annunciations. – Verify engine at go-around thrust. – Selects flaps 9.
Positive Rate of Climb	<ul style="list-style-type: none"> – Confirm positive rate of climb. <p>“GEAR UP”.</p>	<ul style="list-style-type: none"> – Verify positive rate of climb. <p>“POSITIVE RATE”.</p> <ul style="list-style-type: none"> – Position gear lever up. – Selects V_{FS}. – Advises ATC.

CONTINUES ON NEXT PAGE

CONTINUED FROM PREVIOUS PAGE

NORMAL GO-AROUND – ACTIONS AND CALLOUTS		
	PF	PM
When reaching 170 KIAS	“SELECT HEADING and SPEED TWO TEN or NAV”.	<ul style="list-style-type: none"> – Selects appropriate navigation primary source. – Selects Speed 210 kt. – Selects Lateral Mode.
Above 400 ft AGL or Acceleration Altitude	“CLIMB SEQUENCE”. <ul style="list-style-type: none"> – Executes published missed approach or proceed as instructed by ATC. 	<ul style="list-style-type: none"> – Speed check: $V_{FS} - 5$. – Retracts Flaps to Zero. – Selects CLB thrust. – Pushes FLC Button.⁽¹⁾ – If equipped with VNAV pushes VNV button. ⁽²⁾ – When flaps are zero: “FLAPS ZERO”. – Monitor missed approach procedures.
	“AUTOPILOT” (If applicable)	<ul style="list-style-type: none"> – Engages Autopilot. “AUTOPILOT ENGAGED” – (If applicable).

(1) FLC mode commands the pitch to a pre-programmed climb speed schedule (without VNAV).

(2) VFLC mode commands the pitch to the FMS programmed altitude and speed targets. The thrust to the desired climb rate may be selected to the pilots.

NOTE: Callouts are shown in bold text.

ONE ENGINE INOPERATIVE GO-AROUND

Perform the one engine inoperative go-around procedure in a similar manner to AEO, except for the thrust levers selection.

After pressing Go-Around button, advance the Operative Engine Thrust Lever to Max. If the Go-Around maneuver starts before securing the failed engine, advance both Thrust Levers to MAX.

Control yaw with rudder and trim. Rotation must be done at a slower rate, slightly less than on a normal go-around. Set aileron in neutral and use rudder and yaw trim to keep wings level, as high ailerons inputs will raise spoilers and increase drag.

As a reference, the slip/skid indicator shall be approximately $\frac{1}{2}$ to $\frac{1}{4}$ off center and between 0° to 5° of bank, according to speed, gross weight and altitude. Generally the control wheel in the neutral position is a good indication of the lowest drag for single engine.

Verify the GA and ROLL modes annunciated on the FMA. At a positive rate of climb, retract landing gear. The flight director commands a pitch attitude that will follow the GA submode logic. With one engine inoperative the resulting vertical speed will depend on temperature, available thrust and airplane gross weight. The ROLL mode maintains wings leveled.

Select HDG and BANK mode at acceleration altitude.

Advise ATC of your intentions. Either fly a published missed approach procedure or fly the runway specific Engine Failure - Missed Approach procedure.

At V_{FS} with landing gear and flaps retracted, select continuous thrust on Thrust Rating panel and verify continuous thrust (CON) is displayed on the EICAS.

3-35-10	Page 26	Code 01
---------	------------	------------

**ONE ENGINE INOPERATIVE GO-AROUND –
ACTIONS AND CALLOUTS**

	PF	PM
Go-around becomes necessary	<p>“GO-AROUND”.</p> <ul style="list-style-type: none"> – Disengages autopilot. – Presses GO-AROUND Button. – Advances Operative Engine Thrust Lever to MAX. ⁽¹⁾ <p>“FLAPS 9”.</p> <ul style="list-style-type: none"> – Verifies or rotate towards GA pitch attitude. 	<ul style="list-style-type: none"> – Verifies GA annunciations. – Verifies engine thrust at go-around. – Selects GA flaps at 9.
Positive Rate of Climb	<ul style="list-style-type: none"> – Confirms positive rate of climb. <p>“GEAR UP”.</p> <ul style="list-style-type: none"> – Climbs at V_{APP} CLB. – Controls the airplane using rudder and yaw trim in the amount necessary to keep the aileron control in neutral position. 	<ul style="list-style-type: none"> – Verifies positive rate of climb. <p>“POSITIVE RATE”.</p> <ul style="list-style-type: none"> – Positions gear lever up. – Selects V_{FS}. – Advises ATC.

NOTE: ⁽¹⁾Should a go-around be initiated after an engine failure but before securing the failed engine, PF advances both thrust levers to MAX.

CONTINUES ON NEXT PAGE

CONTINUED FROM PREVIOUS PAGE

ONE ENGINE INOPERATIVE GO-AROUND – ACTIONS AND CALLOUTS		
	PF	PM
Acceleration Altitude	<p>“SELECT HEADING, BANK”.</p> <p>“SELECT ALTITUDE HOLD”.</p> <p>“ENGAGE AUTOPILOT”.</p> <p>–Reaching $V_{FS} - 5$: “FLAPS 0”.</p> <p>“SPD AND CONTINUOUS THRUST”.</p>	<p>–Selects HDG and BNK.</p> <p>–Selects Altitude Hold.</p> <p>–Engages AP. –Retracts flaps to 0 then calls. “FLAPS ZERO”.</p> <p>–Reaching V_{FS}: “ V_{FS} ”.</p> <p>Selects SPD on FGC Panel and CON on Thrust Rating Panel.</p>
Climbing to Safe Altitude	<p>–Climbs at V_{FS} to a safe altitude defined on the approach briefing or as assigned by ATC.</p> <p>–Flies runway heading or comply with airport “One Eng SID” or maintain the go-around path defined on the approach briefing.</p>	<p>–Monitors thrust, attitude, speed and missed approach procedures.</p>

NOTE: - Callouts are shown in bold text.

- Do not engage GO-AROUND mode when using autopilot or flight director in basic mode (ROLL or PITCH) unless in wing level condition.

3-35-10	Page 28	Code 01
---------	------------	------------

REVISION 10



ABNORMAL FLAP CONFIGURATION

If flap fails at a specific position, select the desired flap position and use data according to QRH configuration tables. The best performance combination of flap is the one that gives the lower landing coefficient factor.

The following items are valid for all abnormal flap configuration approaches and landings:

- Use of autopilot is recommended;
- If possible reduce gross weight to lowest practicable (burn off fuel) to reduce V_{REF} ;
- Check landing distance (select the longest runway available);
- Limit bank angle to 20° maximum when maneuvering for landing;
- Establish a long final approach, at least 6.5 NM at recommended speed;
- Attitude and speed will be higher than normal;
- Use precision glide slope such as ILS for crosscheck;
- Establish landing configuration early, flight large patterns and long final;
- Plan touchdown at 1000 ft touchdown zone. A go-around should be made if landing occurs beyond touchdown zone;
- Flare enough just to reduce the rate of descent, do not float and touchdown at the normal touchdown zone;
- Over threshold set thrust levers to IDLE;
- After touchdown, apply reverse thrust (if applicable) and brakes without delay.

EGPWS WARNING CORRECTIVE MANEUVER

ACTIONS AND CALLOUTS		
	LSP	RSP
Upon receiving EGPWS Warning	<ul style="list-style-type: none"> - Disengages the Autopilot. - Simultaneously sets thrust levers to MAX position and sets pitch 20° or PLI, whichever is lower.⁽¹⁾ - Climbs to the MSA or MORA. - Clear of terrain resumes leveled flight. - Engages Autopilot. - Resumes normal speed. 	<ul style="list-style-type: none"> - Communicates with ATC. - Scans for visual contact. - Turns FSTN BELTS ON. - Reads MFD Terrain indications to check the obstacle height, guides for the best course of action and indicates when obstacle have been cleared.

NOTE: - If the airplane is operated by day (not by night), in clear visual conditions (not in IMC conditions) and a positive visual verification ensures that no obstacle or terrain hazard exists, the EGPWS alert may be regarded as a reminder.

- ⁽¹⁾ After stabilizing, pitch may be increased above 20°, limited to PLI.

LANDING

GENERAL

This section presents information pertinent to the landing phase of flight that will enhance the ability to make the air-to-ground transition as smooth and safe as it should be.

The airplane must be fully stabilized by 1000 ft from touchdown under IMC conditions and by 500 ft under VMC conditions. A stable approach is a contributing factor to a successful flare and touchdown. Unstable approaches may result in difficult landings with unexpected sink rates, side loads or bounce backs. An approach is considered stabilized when all of the following criteria are met:

- The airplane is on the correct flight path;
- Only small changes in heading/pitch are required to maintain the correct flight path;
- The airplane is in the correct approach speed;
- The airplane is in the correct landing configuration;
- Sink rate is not greater than 1000 ft per minute; if an approach requires a sink rate greater than 1000 ft per minute, a special briefing should be conducted;
- Power setting is appropriate for the airplane configuration;
- All briefings and checklists have been conducted.

LANDING PROCEDURE

For a normal landing procedure, the landing configuration, gear down and flaps should be established early on the final approach or at the outer marker on an ILS or FAF on a non precision approach. Airspeed, power and descent rate also should be stabilized early. Changes in airspeed require changes in thrust and attitude. An airspeed deviation is considered significant if it is 10 kt above target approach speed. Indicated airspeed may not be less than the V_{REF} or V_{APP} .

A significant vertical speed deviation occurs when it is greater than 1000 ft/min (precision approaches) or 1500 ft/min (non-precision approaches) when below 1000 ft AGL. If the stabilized approach parameters are not met before reaching the stabilized approach height, a go-around should be initiated.

SOP-145/1489

REVISION 4

3-40	Page 1	Code 01
------	-----------	------------



Make sure that the airplane is properly trimmed during the approach. This maximizes elevator authority for the flare or in the event of a missed approach.

Plan to touchdown at the runway touchdown zone, which is typically located 1000 ft ahead from the runway threshold. Monitor the final approach path using all reference available. Do not allow the airplane to float in ground effect, which unnecessarily increases the landing distance and risk of a tail strike.

After main wheel touches down, apply manual braking without delay as required for the runway condition and length. Due to airplane geometry care should be taken while easing the nosewheel onto the runway. Pull thrust levers to reverse, (if applicable) and verify spoilers actuation.

If installed, reverse thrust should be selected consistent with runway conditions and applied as required. Apply thrust reversers cautiously and observe how the airplane responds before full reverse is used.

Full reverse thrust should be used when landing over wet, slippery and contaminated runways. Maintain maximum reverse thrust until the airspeed is approximately 80 kt. Then smoothly reduce thrust reverse to MIN REV at 60 kt and idle thrust at 30 kt. Thrust reverser is more effective at high speeds; the use of reverse below 60 kt increases the chances of foreign object ingestion by the engine. If necessary the thrust reversers can be used until the airplane come to a complete stop.

Rudder control is effective to approximately 60 kt. Rudder pedal steering is sufficient for maintaining directional control during the rollout. Do not use the nosewheel steering tiller until reaching taxi speed.

3-40	Page 2	Code 01
------	-----------	------------

As soon as the airplane leaves the runway, the strobe lights must be turned off. However LDG 1, LDG 2 and NOSE lights are switched off, the TAXI light must remain on throughout the taxi regardless of the time of the day.

NOTE: AFM performance values consider the threshold is crossed at the screen height and at V_{REF} or $V_{REF\ NEW}$ according to the inputted reference speed or in accordance with company policies.

LANDING ROLLOUT - ACTIONS and CALLOUTS		
	PF	PM
After Main Wheel touches down	<ul style="list-style-type: none"> Apply manual braking as required. Use Thrust reverser if required. At 60 kt reduces Thrust Levers to MIN REV if Thrust reverser is being used. At 30 kt sets Thrust Levers to IDLE (forward thrust) if Thrust reverser is being used. 	<ul style="list-style-type: none"> Verify Ground Spoiler deployed. Monitors Thrust reverser if it is being used. Monitors airspeed.
Reaching normal taxiing speed, if LSP is not the PF	“MY CONTROLS”.	“YOUR CONTROLS”.
Clearing runway	“AFTER LANDING SEQUENCE”.	-

BRAKES USAGE

The following actions will give the optimum manual braking for all runway conditions:

- Pilot seat and rudder pedals should be adjusted so it is possible to apply maximum braking with full rudder deflection;
- Apply the brakes with no delay after the main landing gear wheels have touched down. Move directly to a single firm and steady brake application and hold pedal pressure until decelerated to taxi speed;
- Do not pump the brakes;
- Carbon brake life is improved when operated in higher temperatures;
- If the landing weight is limited by runway length, full reverse and brakes should be used simultaneously to stop the airplane.

EMERGENCY/PARKING BRAKE

Some Emergency and Abnormal procedures require the pilot to use the Emergency/Parking Brake to stop the airplane during landing.

When this happens, the following protections are not available:

- Locked Wheel Protection;
- Antiskid Protection; and
- Touchdown Protection.

At high speeds, apply the Emergency/Parking Brake handle to stop the airplane monitoring the Emergency/Parking Brake light and maintain steady pressure. The brake system provides sufficient pressure to start braking. As speed decreases the required handle deflection increases to maintain continuous braking.

If a tire burst occurs applying the Emergency/Parking Brake, do not release the Emergency/Parking Brake handle until the airplane stops.

MAXIMUM PERFORMANCE LANDING

Maximum Performance Landing comprehends a set of techniques that leads to decelerate the airplane to a safe speed within minimum landing distance. The following recommendations apply:

- Perform earlier the approach briefing covering approach procedures and speeds: Keep your situation awareness over the stabilized approach and stabilized landing is mandatory for a well-planned and executed approach;
- Use Flaps 45;
- Cross the Threshold at Screen Height of 50 ft and V_{REF} ;
- Avoid extended flare;
- Conduct a positive landing;
- If the airplane is equipped with thrust reversers apply maximum reverse thrust. If necessary the thrust reversers can be used until the airplane comes to a complete stop;
- Immediately after the main landing gear wheels have touched down apply firm and steady maximum manual brakes and hold pedal pressure until the airplane decelerates to a safe taxi speed within the runway;
- Lower nose wheel immediately to the runway. It will decrease lift and increase main landing gear loading.

NOTE: The same technique could be used for Flaps 22 configuration. Nevertheless, the landing distance will increase accordingly.

LANDING ON WET, SLIPPERY OR CONTAMINATED RUNWAYS

Wet or contaminated runways have much lower friction levels than a dry runway; Friction depends on the runway surface, materials and conditions. Runway contamination may reduce friction to very low levels. The FAA defines that a runway is contaminated whenever standing water, ice, snow, slush, frost in any form, heavy rubber, or other substances are present. If such conditions exist at the time of arrival and were not taken into account during dispatch, a landing distance re-assessment must be conducted. The QRH presents tables to aid this analysis.

Hydroplaning always occurs to some degree when operating on fluid-contaminated runway. The degree of hydroplaning depends on the following factors:

- Absence of runway surface roughness and inadequate drainage;
- Depth and type of contaminant;
- Tire inflation pressure.

Additional considerations, as follows, should be taken:

- Use Maximum Performance Landing techniques;
- Conduct a positive landing to ensure initial wheel spin-up and initiate firm ground contact upon touchdown. Such technique will positively reduce hydroplaning on wet runways and reduces the strength of any ice bond that, during flight, might have been eventually formed on brake and wheel assemblies;
- If the airplane is equipped with thrust reversers apply maximum reverse thrust. Do not use asymmetric reverse thrust on slippery and icy runways;
- Apply firm and symmetrical brakes pedal pressure;
- Do not apply Emergency/Parking Brake if the airplane has lost the friction with the runway, as it will inhibit anti-skid protection. Maintain runway centerline and keep braking;
- Landing on wet, slippery or contaminated runway with tail wind is not recommended.

NOTE: At operator's discretion, landing on wet runways could be performed not using thrust reversers. Landing performance must comply with the runway distance available.

3-40	Page 6	Code 01
------	-----------	------------

CROSSWIND LANDING

Four methods for crosswind landing can be used:

- **Sideslip:** In the sideslip condition, the airplane's longitudinal axis remains parallel to the runway course, but the airplane no longer flies straight along its original track. Downwind rudder combined with aileron applied into the wind. The upwind wheels touchdown before downwind wheels.
- **Crab:** Proper rudder and upwind aileron. On very slippery runways the crab may be maintained to touchdown, reducing the drift toward the downwind when touchdown.
- **De-Crab:** On final approach the crab is accomplished, just prior to touchdown while flaring, downwind rudder is applied to align the airplane with the runway centerline simultaneously with aileron control (to keep wings level) into the wind. Both main landing gear touchdown simultaneously.
- **Crab and Sideslip:** The crab method is applied until the touchdown. When the upwind wheels touchdown, a slight increase in downwind rudder simultaneously with aileron aligns the airplane with the runway centerline while keep the wing level. This combined method may be used during strong crosswind.

Especially when landing on slippery runways, during landing rollout with crosswind and reverse thrust applied as the airplane starts to have any tendency to weathervane into the wind a reverse thrust side force component will be added to the crosswind component and may result in a tendency to drift the airplane to the side of the runway. On that condition the landing gear tire cornering forces available may be not sufficient to counteract that drift.

To realign the airplane with the runway centerline momentarily set thrust reverse to IDLE and release the brakes. This minimizes the reverse thrust side force component and improves the landing gear tire cornering forces available to realign the airplane with the runway centerline.

Apply rudder and differential braking as required to realign the airplane with the centerline. Once the airplane is back on the centerline reapply braking and symmetrical reverse thrust as required to decelerate the airplane.

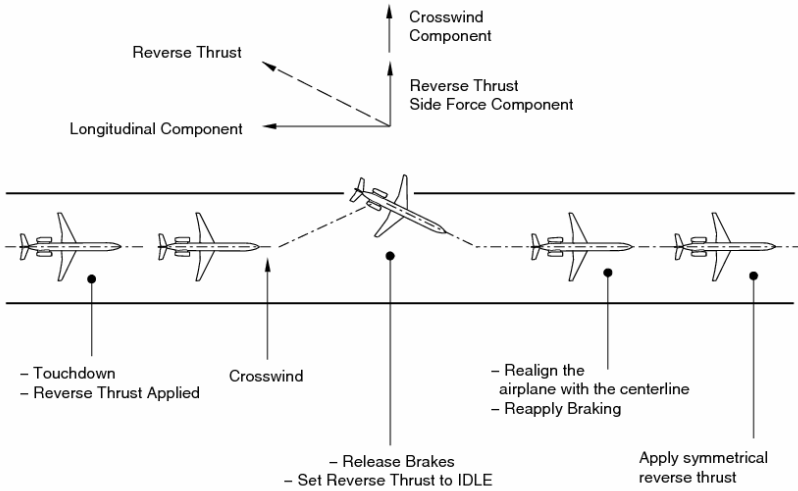

EM145AQM020096A.DGN

OPERATIONAL FACTORS AFFECTING LANDING DISTANCE

The required landing distance for dispatch is calculated considering that the landing will be performed with the airplane crossing the runway threshold at the screen height of 50 ft and at V_{REF} using maximum manual braking.

In order to stay within the operational margins of the required landing distance the crew must conduct a stabilized approach and landing using the correct landing techniques.

Several environment factors, such as airport elevation, runway slope, runway conditions and winds may affect the landing distance.

3-40	Page 8	Code 01
------	-----------	------------

However, aside those factors, if the approach and landing is performed with deviations from the standard procedures, the operational margin available will be reduced or even exceeded.

The following operational factors, among others, have effect over the airplane actual landing distance:

- Crossing runway threshold with airspeed above V_{REF} ;
- Crossing runway threshold above the screen height;
- Extended Flare;
- Unstabilized approach.

If the airplane crosses the threshold with 10 kt above the V_{REF} , the landing distance increases by approximately 16%. Crossing the threshold at 70 ft instead of the normal screen height increases the landing distance by approximately 20%.

Extending the flare during landing increases the landing distance because the airplane will touchdown the runway in a point ahead of the runway touchdown zone, usually located at 1000 ft from the runway threshold. Extending the flare by 3 seconds increases the landing distance by approximately 35%.

Considering an unstabilized approach, with the airplane crossing the threshold at 100 ft, above V_{REF} and with 3 seconds of extended flare, the landing distance increases by approximately 70%. In this situation the distance necessary to stop the airplane exceeds the operational margins provided by the dispatch required landing distance.

RECOVERY FROM OFFSET POSITION

According to ICAO, required visual references means the section of the visual aids or of the approach area which should have been in view for sufficient time for the pilot which made the assessment of the airplane position and rate of position change, in relation to the desired flight path.

Lateral and vertical offset may occur during any kind of approach, when pilot cannot assess horizontal and/or vertical flight path, which requires major corrections on the final visual section of flight.

Upon recognizing an offset position, the pilot determines whether a correction can be safely performed.

NOTE: In case of any doubt about a safe approach and landing, an immediate go-around should be done.

On lateral and/or vertical offset approach, adequate monitoring of pitch attitude, bank angle and power settings is required, together with cockpit raw data instruments available in order to prevent crew disorientation.

Lateral Offset

For lateral offset recovering, pilot shall select a reference point on the extension of the runway centerline which is about half the distance to the touchdown point, and establish airplane toward this point. Maintain proper thrust, airspeed and flight path. Shortly before crossing the aiming point, pilot shall start turning to get established start a turn aiming for the extended inner edge line.

Vertical Offset

High sink rates at low thrust settings are unsafe and may result in a touchdown short of the runway or a high landing. A flat approach at high thrust settings, if too low, may lead to an extended flare and long floating landing.

To correct a vertical offset, the following procedures shall apply, considering that pilot must adjust the airplane to stabilize on the correct flight path as soon as practicable, taking immediate and precise action:

- For a low offset position, establish level flight;
- For a high offset position use maximum permissible sink rate until stabilized on the correct flight path.

WINDSHEAR

The most important way to cope with windshear is to avoid areas of known or potential windshear occurrence such as thunderstorms.

Severe windshear may be defined as a rapid change in wind direction and/or velocity that results in airspeed changes greater than 15 kt or vertical speed changes greater than 500 ft/min.

Whenever a windshear is suspected during landing the following precautions should be taken:

- During approach maintain the Vap with the applicable wind additive corrections.
- Select Flaps 22 unless limited by other landing performance consideration.
- If possible plan to land on the longest runway available, with the lowest possibility of a windshear encounter.
- Adjust the Weather Radar and get the best information about weather formations on the airplane path.
- Crew should monitor airspeed trend during approach. In the first evidence of Windshear initiate a Go Around. If necessary perform the windshear escape maneuver procedure.
- Develop an awareness of normal airspeed, attitude and vertical speed. The crew should closely monitor the vertical flight path instruments, such as, vertical speed and altimeters, and call out any deviations.

WINDSHEAR RECOVERY TECHNIQUES

The windshear escape maneuver should be performed whenever the following happens:

- A warning windshear is annunciated during approach.
PFD: WDSHEAR (red).
Voice message: "WINDSHEAR, WINDSHEAR, WINDSHEAR".
- A caution windshear is annunciated during approach and the pilot decides to perform the windshear recovery technique.
PFD: WDSHEAR (amber).
Voice message: "CAUTION WINDSHEAR".
- Whenever the pilot decides to perform the recovery techniques due to the presence of windshear clues without EGPWS announcement.

WINDSHEAR - ACTIONS and CALLOUTS

	PF	PM
	<p>“WINDSHEAR”. (Pilot first noticing the windshear condition).</p>	
After takeoff, during initial climb or approach/landing	<ul style="list-style-type: none"> Advances thrust levers to MAX detent. <p>“MAX”.</p> <ul style="list-style-type: none"> Presses Go-Around button. Follow Flight Director Escape Guidance Cue. ⁽¹⁾ 	<ul style="list-style-type: none"> Maintains the airplane configuration (gear/flaps). Keep monitoring vertical speed and altimeters and call out any deviations.
With terrain clearance assured, above 1500 ft AGL or after WDSHEAR label removed from PFD	<ul style="list-style-type: none"> Reduces thrust levers to THRUST SET or below (as required). <p>“GO AROUND”.</p> <ul style="list-style-type: none"> Presses Go-Around button. With the airspeed greater than V_{REF}: “FLAPS _ ” ⁽²⁾ 	<ul style="list-style-type: none"> Selects GA Flap. ⁽²⁾
Positive Rate of Climb	<ul style="list-style-type: none"> Confirms positive rate of climb. <p>“GEAR UP”.</p>	<ul style="list-style-type: none"> Verifies positive rate of climb. <p>“POSITIVE RATE”.</p> <ul style="list-style-type: none"> Positions Landing Gear Lever up. Selects V_{FS}. Advises ATC.

User: aherrera - Printed By myTechCare - Aug 09/22 - 14:17:22

WINDSHEAR - ACTIONS and CALLOUTS		
	PF	PM
Positive Rate of Climb	<p>“SELECT FMS ⁽³⁾ AND HEADING (NAV)”.</p>	<ul style="list-style-type: none"> • Selects appropriate navigation primary source. • Selects Lateral Mode.
Acceleration Altitude	<p>“CLIMB SEQUENCE”.</p> <ul style="list-style-type: none"> • Executes published missed approach or proceed as instructed by ATC. • Resumes automation at pilot’s discretion. 	<ul style="list-style-type: none"> • Retracts Flap on schedule. • Selects CLB thrust. • Selects SPD, set 210 kt or FLC on the FGS. • At flap zero calls: “FLAP ZERO”.

NOTE: - In case of Windshear Escape Maneuver without EGPWS announcement:

- Disengages the Autopilot,
 - Advance thrust levers to MAX,
 - Press the Go-Around button,
 - Set the Pitch to 20° or PLI, whichever is lower.
- ⁽¹⁾ For Caution Windshear, the Flight Director Escape Guidance Cue is activated only after pressing Go-Around button.
 - ⁽²⁾ Only applicable for Windshear Escape Maneuver initiated during approach or landing.
 - ⁽³⁾ Only applicable when FMS is not the navigation source.

LOW VISIBILITY LANDING

When flying under conditions of haze, smoke, dust, glare or darkness, aircraft height may appear higher than it actually is. Shadows are one of the key factors in depth perception.

This effect is also encountered during night landings, or when smoke or dust appears lying low across the threshold. The effect varies with individuals and is modified by the intensity and clarity of runway lighting. Situational alert must be emphasized on precision approaches, since pilots tend to reduce power and drop below glide path as soon as the runway is in sight.

Moisture on windshield interferes with visibility and may cause any type of glide path illusion. Light rays will refract (bend) as they pass through the layer of moisture of the windshield. You can appear to be above or below the glide path or left or right of centerline. This can be as much as 200 ft error at one mile from the runway which, when combine with effect mentioned above, could result in risk of landing short of runway threshold or in a long landing.

Crosscheck VSI for rate of descent and fly to the touchdown aim point.

REJECTED LANDING

The rejected landing procedure is similar to the go-around procedure.

Auto spoilers will retract as thrust levers are advanced for a rejected landing initiated after touchdown. Attention must be given to the intended flight path as the published missed approach procedure may not be valid after passing the published missed approach point.

If thrust reverse is used, after reverse thrust is initiated, a full stop landing must be made due to the time the reverser requires to transition from reverse to forward thrust and the possibility that it does not stow back in the forward thrust position.

3-40	Page 14	Code 01
------	------------	------------

REJECTED LANDING - ACTIONS and CALLOUTS

	PF	PM
Go-around	<p>“GO-AROUND”.</p> <ul style="list-style-type: none"> • Press either Go Around Button. • Moves thrust levers to MAX. • Rotates smoothly the airplane to the FD pitch indication (GA). • With the airspeed greater than V_{REF}. <p>“FLAPS 9”.</p>	<ul style="list-style-type: none"> • Verify GA annunciations. • Verify engine at go-around thrust. • Selects flaps 9.
Positive Rate of Climb	<ul style="list-style-type: none"> • Confirm positive rate of climb. <p>“GEAR UP”.</p>	<ul style="list-style-type: none"> • Verify positive rate of climb. <p>“POSITIVE RATE”.</p> <ul style="list-style-type: none"> • Position gear lever up. • Advises ATC.

NOTE: The V_{REF} should be used as a guidance to initiate the rotation of the airplane.

CONTINUES ON NEXT PAGE

CONTINUED FROM PREVIOUS PAGE

REJECTED LANDING - ACTIONS and CALLOUTS		
	PF	PM
400 ft AGL	“SELECT HEADING (NAV)” .	<ul style="list-style-type: none"> • Selects appropriate navigation primary source. • Selects Lateral Mode.
Acceleration Altitude	“CLIMB SEQUENCE” . <ul style="list-style-type: none"> • Executes published missed approach or proceed as instructed by ATC. 	<ul style="list-style-type: none"> • Speed check: $V_{FS} - 5$. • Retracts Flaps to Zero. • Selects CLB thrust. • Selects SPD. • Set speed 210 kt or FLC on the FGS. • When flaps are zero: “FLAPS ZERO”. • Monitor missed approach procedures.

NOTE: Callouts are shown in bold text.

BOUNCED LANDING

The bouncing occurs more frequently during landings by one or a combination of the following factors:

- Windshear;
- Low-level turbulence;
- High flare initiation;
- Excessive rate of descent;
- Late flare initiation;
- Incorrect flare technique;
- Excessive airspeed;
- Power on touchdown.

3-40	Page 16	Code 01
------	------------	------------

REVISION 9

The key factor for a successful landing is a stabilized approach and proper thrust/flare coordination. Do not extend the flare at idle thrust as it will significantly increase landing distance. Reducing to idle before the flare will also require an increase in pitch. Flaring high and quickly reducing thrust to idle can cause the airplane to settle abruptly.

Do not apply stabilizer trim during the flare.

Recovery from Light Bounce

When a light bounce occurs, maintain or re-establish a normal landing attitude. Increasing pitch can lead to a tail strike. Beware of the increased landing distance and use power as required to soften the second touchdown. It is very difficult to evaluate landing distance remaining and the airplane energy.

Recovery from a Severe Bounce

When a more severe bounce occurs, initiate a go-around and do not attempt to land. Press go-around button and advance thrust levers to MAX. Hold the flare attitude until the engines spool up and reset stabilizer trim, then follow normal go-around procedures.

If the airspeed has dropped below the V_{REF} initiate the go-around procedure and retract the flaps to go around flaps setting only when the airspeed becomes greater than V_{REF} .

TAIL STRIKE DURING LANDING

Tail strikes are more frequent during landings than takeoffs.

Based upon information gathered from tail strike occurrences, deviation from the normal landing maneuver, below, is the main cause of tail strikes. The mistakes most commonly made are:

- Approach at improper pitch, speed, thrust and glide path;
- Prolonged flare, hold-off for a smooth touchdown;
- Starting to flare the aircraft too high above the runway;
- Improper crosswind correction during flare;
- Over-rotation during a touch and go.

Of these commonly made mistakes, flaring the aircraft too high above the runway has the greatest potential for a tail strike and resulting damage. When the flare is started too high above the runway, airspeed will decrease below V_{REF} . When placed in this situation, the tendency is to continue to increase pitch in an effort to arrest the excessive sink rate. The correct action to take is to immediately lower the pitch attitude and fly the airplane to the runway before the airspeed dissipates any further. This corrective action will prevent a tail strike.

Lack or poor handling could lead to a destabilized approach thus increasing the tail strike exposure.

OVERWEIGHT LANDING

Overweight landing may safely be accomplished by using normal landing procedures and techniques. There are no adverse handling characteristics associated with heavier than normal landing weights.

Select the longest available runway, when feasible. Slope and wind effects should also be considered.

Where possible avoid landing in tailwinds, on runways with negative slope or runways with less than normal braking conditions.

Reduce the landing weight as much as possible. To save time and at pilot discretion this can be done using high drag configuration (landing gear and/or speed brake) and flying at a lower altitude (respect MORA and MSA).

Wind additives may be impacted by flap placard speeds (V_{FE}).

At weights above the maximum landing weight, the final approach maximum wind correction may be limited by the maximum flap extended speed (V_{FE}).

Configure the airplane earlier so you will have more time to get used to the higher approach speeds.

Do not carry excess airspeed on final.

It is recommended to land under VMC. You will have more time to focus on the handling of the airplane rather than on the instruments panel.

3-40	Page 18	Code 01
------	------------	------------

Brake energy will not be exceeded for flaps 22 or 45 landing at all gross weights. Although, give special attention to wet or slippery runways. The brake energy limits may be exceeded when landing at high gross weights at speeds associated with non-normal procedures requiring flaps set at 45 or less.

Try a smooth landing. In the other hand, do not allow the aircraft to float above the runway. Consider a go-around if a long landing is likely to occur.

The maximum rate of descend is 300 ft/min at touchdown. Use maximum reverse thrust down to 60 kt if applicable. If stop capability is in doubt use it until certain that the airplane will stop within limitations. Use brakes consistent with runway length.

Maintenance inspection is required after landing (report AGW and rate of descent on the TLB).

NOTE: Alert ground crew if brake temperature is too high.

TOUCH AND GO LANDING

The primary objective of touch and go procedure is approach and landing training practice and to reduce the amount of training time wasted in taxing the airplane back to the holding point.

In order to maintain a high level of safety, they must be conducted in a proper disciplined manner.

BASIC CONSIDERATIONS

- Reverse thrust and brakes will not be used during touch and go procedures;
- Follow the published Visual Approach Pattern to configure the airplane.

The following techniques are to be used:

- The trainee should accomplish a normal final approach and landing;

- On final approach, the Altitude Selector should be set to Traffic Altitude;
- The trainee will land the nose wheel after main landing gear touchdown and track the runway centerline;
- The instructor move the flap handle to Flaps 9, configure pitch trim so that the green pointer is indicating to the green takeoff band, yaw and roll trim to neutral;
- The trainee will press GO-AROUND button and manually advance the thrust levers to MAX position;
- The instructor will check thrust;
- If the trainee is the PF, he/she will keep his/her hand on throttles to prevent any inadvertent reduction of power or unwanted stop;
- The trainee will rotate performing a normal TO procedure. Vref should be used as a speed reference to rotate the airplane;
- At positive rate of climb, the instructor will retract the landing gear, following a normal climb sequence. The final flaps setting (flaps 0 or flaps 9) should be selected in accordance with the training flight pattern to be flown.

General RTO guidance can be used to decide to interrupt the touch and go procedure. In case of emergency, the decision to abort is solely at the instructor's discretion. He/She will call **"REJECT"** and simultaneously take control of the airplane and bring it to a halt using maximum braking and reverse. Once the airplane has stopped, he/she will call for any appropriate Emergency/Abnormal checklist.

The decision to discontinue a Touch and Go after the application of TO power, must only be taken if the instructor is certain that the airplane cannot safely fly.

TOUCH AND GO - ACTIONS AND CALLOUTS

	PF	PM
After main wheels touch down	<ul style="list-style-type: none"> Maintains the airplane on the center line. Continuously checks the remaining takeoff distance. 	<ul style="list-style-type: none"> Selects flaps 9. Sets trims.
With the pitch trim in the green band	<ul style="list-style-type: none"> Presses the GO-AROUND button. Sets thrust levers at MAX position. 	“GO”
Engines spooled up and rotation speed	<ul style="list-style-type: none"> Rotates the airplane when reaching V_{REF} following the flight director guidance. 	“ROTATE”
Positive rate of climb	“GEAR UP”	“POSITIVE RATE” <ul style="list-style-type: none"> Selects landing gear up.
400 ft AGL	“SELECT HEADING”	<ul style="list-style-type: none"> Selects Heading mode.
1000 ft AGL	“CLIMB SEQUENCE”	“ACCELERATION ALTITUDE” <ul style="list-style-type: none"> Selects FLC. Retracts flaps on schedule. Selects CLB thrust

User: aherrera - Printed By myTechCare - Aug 09/22 - 14:17:22

DITCHING

This procedure is intended for use in case of emergency landing on water and enough time is available to prepare the passengers.

If ATC contact is possible, set transponder code 7700 (if not transmit in blind), transmit a distress messages **"MAYDAY"** with your present position, course, altitude, speed, situation, time available and intention of touchdown. If possible ditch near shorelines, offshore platforms or boats.

When the decision has been made to ditch the airplane, using the QRH, complete the ditching preparation checklist.

Pilot should inform pursers and passengers of the upcoming event and passes the following information:

- Nature of the ditching;
- Review emergency checklist, landing and evacuation procedures;
- How the flight crew will signal cabin crew to start evacuation;
- How much time is left;
- Exits available for evacuation and crew duties;
- Secure all loose equipment in cabin and cockpit;
- Any further instructions that might be deemed necessary;
- Advise crew and passengers to prepare for ditching and assume protective position. It must be transmitted from the cockpit 30 seconds before ditching or at any moment an accident occurs, by using the phraseology: **"IMPACT/IMPACT/IMPACT"**.

Plan to land with maximum flap available and burn off fuel to a minimum onboard to increase buoyancy. Leave the gear UP.

Consider landing parallel to waves taking in account wind direction and sea condition. If at all possible, land parallel to the swell, not across it. The best location is along the crest of the swell which minimizes the chance of a wingtip digging into the water. Second best is in the trough or bottom of the swell.

Maintain airspeed at V_{REF} and less than 180 ft/min rate of descent or as low as possible, rotate smoothly attitude (approx 4° nose up) during flare and keep flying the airplane at all times until touchdown. After touchdown, reduce thrust to idle.

After the airplane has come to rest, proceed to assigned ditching stations and evacuate as soon as possible, assuring that all passengers are out of the aircraft. Note that entry into water is always considered "catastrophic" and the cabin crew will initiate evacuation without further instructions from the flight deck.

User: aherrera - Printed By myTechCare - Aug 09/22 - 14:17:22

DITCHING – ACTIONS AND CALLOUTS

	PF	PM
In Flight	<ul style="list-style-type: none"> • Notifies cabin crew. • Notifies ATC. 	<ul style="list-style-type: none"> • Sets transponder to 7700. • Selects No Smoking/ Fasten Seat Belts signs ON.
At 10000 ft AGL	<ul style="list-style-type: none"> • Monitor cabin rate. 	<ul style="list-style-type: none"> • Presses the pressurization DUMP button. • Pulls GPWS CB (J7, J8,) and aural warning CB (B4, E30) Pulls. • Emergency Lights ON.
	<ul style="list-style-type: none"> • Sets ELT ON. • Adjust altimeters and set landing data. 	
At 1000 ft AGL	<ul style="list-style-type: none"> • Checks that passenger cabin procedures are completed. • Monitors cabin altitude. 	<ul style="list-style-type: none"> • Packs 1 and 2 PUSH OUT. • Engine Bleeds 1 and 2 PUSH OUT.
	<ul style="list-style-type: none"> • Review After Ditching Procedures. 	
Before Ditching	<p>“FLAPS 45”.</p> <ul style="list-style-type: none"> • Confirms landing gear UP. 	<ul style="list-style-type: none"> • Notifies ATC about ditching position. • Sets flaps.

CONTINUES ON NEXT PAGE

User: aherrera - Printed By myTechCare - Aug 09/22 - 14:17:22

CONTINUED FROM PREVIOUS PAGE

DITCHING – ACTIONS AND CALLOUTS		
	PF	PM
Just before water contact	<ul style="list-style-type: none"> • Adjusts landing profile. • Maintains V_{REF} and minimum rate of descent. 	– Alerts cabin crew: “IMPACT, IMPACT, IMPACT” .

CONTINUES ON NEXT PAGE

User: aherrera - Printed By myTechCare - Aug 09/22 - 14:17:22

FORCED LANDING

This procedure is intended for use in case of emergency landing outside an airport and enough time is available to prepare the passengers.

Set transponder code 7700, if ATC contact is possible (if not transmit in blind), transmit a distress messages “**MAYDAY**” with your present position, course, altitude, speed, situation, time available and intention of touchdown.

- Plan to land with flap 45;
- Burn of fuel to a practical minimum reducing the touchdown speed;
- If engine(s) is(are) running perform a landing using thrust to maintain a minimum rate of descent;
- An extended landing gear will absorb part of initial impact load.

Pilot should inform pursers and passengers of the upcoming event and passes the following information:

- Nature of the failure;
- Type of evacuation and crew duties;
- Review emergency checklist, landing and evacuation procedures;
- How the flight crew will signal cabin crew to start evacuation;
- How much time is left;
- Secure all loser equipment in cabin and cockpit;
- Any further instructions that might be deemed necessary;
- The order to assume protective position must be transmitted from the cockpit 30 seconds before landing or at any moment an accident occurs, by using the following phraseology: “**IMPACT/IMPACT/IMPACT**”.

FORCED LANDING – ACTIONS AND CALLOUTS

	PF	PM
In Flight	<ul style="list-style-type: none"> • Notifies cabin crew. • Notifies ATC. 	<ul style="list-style-type: none"> • Sets transponder to 7700. • Selects No Smoking/ Fasten Seat Belts signs ON.
At 10000 ft AGL	<ul style="list-style-type: none"> • Monitors cabin rate. 	<ul style="list-style-type: none"> • Presses pressurization DUMP Button. • Pulls GPWS CB (J7, J8,) and aural warning CB (B4, E30) Pulls. • Sets ELT ON (LSP). • Emergency Lights ON.
	<ul style="list-style-type: none"> • Sets ELT ON. • Adjust altimeters and set landing data. 	
Before landing	<ul style="list-style-type: none"> • Review After Landing Procedures. 	
	<p>“FLAPS 45”.</p> <p>“GEAR DOWN”.</p>	<ul style="list-style-type: none"> • Notify ATC about forced landing position. • Sets flaps. • Extends landing gear using landing gear lever or alternate gear extension lever as required.

CONTINUES ON NEXT PAGE

User: aherrera - Printed By myTechCare - Aug 09/22 - 14:17:22

CONTINUED FROM PREVIOUS PAGE

FORCED LANDING – ACTIONS AND CALLOUTS		
	PF	PM
Just before touchdown	<ul style="list-style-type: none"> • Adjusts landing profile. • Maintain V_{REF} and minimum rate of descent. 	<ul style="list-style-type: none"> • Fire Extinguishing Handles PULL, APU Shutoff Valve PUSH IN. • Alerts cabin crew: “IMPACT, IMPACT, IMPACT”.

CONTINUES ON NEXT PAGE

User: aherrera - Printed By myTechCare - Aug 09/22 - 14:17:22

CONTINUED FROM PREVIOUS PAGE

FORCED LANDING – ACTIONS AND CALLOUTS		
	LSP	RSP
After landing	<ul style="list-style-type: none"> • Reduces thrust levers to idle. • Alerts cabin crew: “INITIATE EVACUATION”. 	<ul style="list-style-type: none"> • Engines and APU Fire Extinguishing Bottles (if necessary) DISCHARGE. • Fuel Pumps Pwr 1 and 2 OFF. • Hyd Elec Pumps 1 and 2 OFF. • Select sbth batteries knobs OFF.

NOTE: Callouts are shown in bold text.

User: aherrera - Printed By myTechCare - Aug 09/22 - 14:17:22