

UNITED STATES

**DISPATCH DEVIATIONS
PROCEDURES MANUAL**

EMBRAER S.A.

THIS MANUAL HAS BEEN PREPARED IN COMPLIANCE WITH THE EMB-135, EMB-145 MMEL, REVISION 17, ISSUED BY FAA. IN CASE OF CONFLICTING INFORMATION BETWEEN THIS MANUAL AND THE MMEL, THE MMEL MUST PREVAIL.

THIS DOCUMENT IS APPLICABLE TO ALL EMB-135 MODELS AND CURRENT EMB-145 MODELS (EXCEPT EMB-135BJ MODEL).

NOTE: THE EMB-135KE AND EMB-135KL MODELS HAVE THE COMMERCIAL DESIGNATIONS OF ERJ-140ER AND ERJ-140LR, RESPECTIVELY.

DDPM-145/1116-02

NOVEMBER 10, 2000

REVISION 12 – JUL 30, 2015

In connection with the use of this document, Embraer does not provide any express or implied warranties and expressly disclaims any warranty of merchantability or fitness for a particular purpose. This document contains trade secrets, confidential, proprietary information of Embraer and technical data subject to U.S. Export Administration Regulation ("EAR") and other countries export control laws and regulations. Diversion contrary to the EAR and other laws and regulations is strictly forbidden. The above restrictions may apply to data on all pages of this document.

Copyright © 2015 by Embraer S.A. All rights reserved.



CUSTOMER COMMENT FORM

Dispatch Deviations Procedures Manual DDPM-145/1116

Please use this Customer Comment Form to notify us of any discrepancies or problems you find in the Dispatch Deviations Procedures Manual. We would also welcome constructive suggestions on how we can further improve our documentation or service.

Your feedback will be acknowledged, and we will advise you of the action we intend to take.

Sincerely,
Embraer Flight Operations Support

Please return this form to:

Embraer S.A.
Flight Operations Engineering & Support
Av. Brigadeiro Faria Lima, 2170 PC176
CEP 12227-901
São José dos Campos - SP - BRASIL
P.O. Box 8050

Phone: +55 12 3927-1706
Fax: +55 12 3927-2477
E-mail: opereng@embraer.com.br

HIGHLIGHTS OF CHANGE

REVISION 12 – JUL 30, 2015

- 23-24-00 Included a new item "Controller-To-Pilot Data Link (CPDLC)".
- 25-60-04 Included a new item "Life Raft".
- 27-40-01 Updated operational note for better clarification.
- 28-21-01 Updated maintenance procedure for flight crewmember accomplishment.
- 28-40-00 Updated operational procedure changing dash indication into unreliable information since it is possible to present zero indication.
- 30-31-03 Included a new item "Pitot Lines Heater".
- 30-41-04 Included a new item "Rain Repellent Coating".
- 32-50-02 Updated placard information and maintenance procedure with same MMEL nomenclature.
- 34-24-02 Included a new item "Standard Barometric Pressure (STD) Button on ISIS".
- 34-43-00 Updated item including a note regarding TCAS inoperative.
- 35-11-03 Included a new item "Oxygen-Cylinder Pressure Relief Disc (Green Disc)".
- 36-11-05 Updated maintenance note since information was very restrictive for MMEL purposes.
- 49-00-00 Deleted maintenance task for APU bleed valve closed since there is no APU bleed when it is deactivated.
- 52-70-00 Updated maintenance procedure including deactivation task for other doors.
- MMEL AMENDMENTS Created a new special operation requirements "ADS-B OUT".

**DISPATCH
DEVIATIONS
PROCEDURES
MANUAL**



- **FERRY FLIGHT** Updated Ferry Flight for deactivated spoiler including VREF information for landing.
- **SPECIAL DISPATCH PROCEDURES** Created a new dispatch condition "Missing/ Damaged Bonding Jumpers".

Page	Code
2	02

LIST OF EFFECTIVE PAGES

ORIGINAL 0 NOV 10, 2000
 REVISION 1 AUG 07, 2001
 REVISION 2 DEC 14, 2001
 REVISION 3 JUN 28, 2002
 REVISION 4 DEC 20, 2002
 REVISION 5 JUN 30, 2003
 REVISION 6 JUN 30, 2004
 REVISION 7 AUG 30, 2006
 REVISION 8 APR 25, 2008
 REVISION 9 DEC 10, 2009
 REVISION 10 MAR 01, 2011
 REVISION 11 FEB 05, 2014
 REVISION 12 JUL 30, 2015

* Title	REVISION 12	EICAS-3	REVISION 9
* A	REVISION 12	EICAS-4	REVISION 9
* B	REVISION 12	EICAS-5	REVISION 10
* C	REVISION 12	EICAS-6	REVISION 10
* D	REVISION 12	EICAS-7	REVISION 10
i	REVISION 9	EICAS-8	REVISION 11
* ii	REVISION 12	EICAS-9	REVISION 10
* iii	REVISION 12	EICAS-10	REVISION 10
iv	REVISION 11	EICAS-11	REVISION 10
v	REVISION 10	EICAS-12	REVISION 10
* vi	REVISION 12	EICAS-13	REVISION 11
vii	REVISION 9	EICAS-14	REVISION 10
viii	REVISION 9	EICAS-15	REVISION 10
* ix	REVISION 12	EICAS-16	REVISION 10
* x	REVISION 12	21-1	REVISION 9
* xi	REVISION 12	21-2	REVISION 9
* xii	REVISION 12	21-3	REVISION 11
* xiii	REVISION 12	21-4	REVISION 11
* xiv	REVISION 12	21-5	REVISION 9
1	REVISION 9	21-6	REVISION 11
2	REVISION 9	21-7	REVISION 11
EICAS-1	REVISION 9	21-8	REVISION 9
EICAS-2	REVISION 9	21-9	REVISION 9

* Asterisk indicates pages revised, added or deleted by the current revision.

DDPM-145/1116

REVISION 12

LEP	Page A	Code 02
-----	-----------	------------

**DISPATCH
DEVIATIONS
PROCEDURES
MANUAL**



21-10.....REVISION 11	* 27-6.....REVISION 12
21-11.....REVISION 9	27-7.....REVISION 11
21-12.....REVISION 9	27-8.....REVISION 9
21-13.....REVISION 11	27-9.....REVISION 10
21-14.....REVISION 9	27-10.....REVISION 9
21-15.....REVISION 9	27-11.....REVISION 9
21-16.....REVISION 9	27-12.....REVISION 9
22-1.....REVISION 9	28-1.....REVISION 11
22-2.....REVISION 9	28-2.....REVISION 9
23-1.....REVISION 11	* 28-3.....REVISION 12
* 23-2.....REVISION 12	28-4.....REVISION 10
* 23-3.....REVISION 12	28-5.....REVISION 10
* 23-4.....REVISION 12	28-6.....REVISION 10
* 23-5.....REVISION 12	28-7.....REVISION 10
23-6.....REVISION 9	28-8.....REVISION 10
23-7.....REVISION 9	28-9.....REVISION 11
23-8.....REVISION 9	* 28-10.....REVISION 12
24-1.....REVISION 9	28-11.....REVISION 10
24-2.....REVISION 9	28-12.....REVISION 10
24-3.....REVISION 9	28-13.....REVISION 10
24-4.....REVISION 9	28-14.....REVISION 10
25-1.....REVISION 9	29-1.....REVISION 10
25-2.....REVISION 9	29-2.....REVISION 9
25-3.....REVISION 9	29-3.....REVISION 9
25-4.....REVISION 10	29-4.....REVISION 10
25-5.....REVISION 10	29-5.....REVISION 10
* 25-6.....REVISION 12	29-6.....REVISION 10
* 25-7.....REVISION 12	29-7.....REVISION 9
25-8.....REVISION 11	29-8.....REVISION 9
26-1.....REVISION 10	29-9.....REVISION 9
26-2.....REVISION 9	29-10.....REVISION 10
26-3.....REVISION 9	30-1.....REVISION 9
26-4.....REVISION 9	30-2.....REVISION 9
26-5.....REVISION 9	30-3.....REVISION 9
26-6.....REVISION 9	30-4.....REVISION 9
27-1.....REVISION 10	30-5.....REVISION 9
27-2.....REVISION 11	30-6.....REVISION 9
27-3.....REVISION 9	30-7.....REVISION 11
27-4.....REVISION 9	30-8.....REVISION 11
27-5.....REVISION 11	30-9.....REVISION 11

* Asterisk indicates pages revised, added or deleted by the current revision.

LEP	Page B	Code 02
-----	-----------	------------

REVISION 12

30-10.....	REVISION 11	35-2	REVISION 9
30-11.....	REVISION 11	35-3	REVISION 9
* 30-12.....	REVISION 12	35-4	REVISION 9
* 30-13.....	REVISION 12	36-1	REVISION 9
30-14.....	REVISION 11	* 36-2	REVISION 12
31-1.....	REVISION 9	36-3	REVISION 9
31-2.....	REVISION 9	36-4	REVISION 9
31-3.....	REVISION 9	36-5	REVISION 10
31-4.....	REVISION 9	36-6	REVISION 9
32-1.....	REVISION 9	38-1	REVISION 9
32-2.....	REVISION 9	38-2	REVISION 9
32-3.....	REVISION 9	45-1	REVISION 9
32-4.....	REVISION 10	45-2	REVISION 9
32-5.....	REVISION 10	46-1	REVISION 9
32-6.....	REVISION 10	46-2	REVISION 9
* 32-7.....	REVISION 12	* 49-1	REVISION 12
32-8.....	REVISION 9	49-2	REVISION 9
33-1.....	REVISION 9	49-3	REVISION 9
33-2.....	REVISION 9	49-4	REVISION 9
33-3.....	REVISION 9	* 52-1	REVISION 12
33-4.....	REVISION 9	* 52-2	REVISION 12
33-5.....	REVISION 9	52-3	REVISION 9
33-6.....	REVISION 9	52-4	REVISION 9
33-7.....	REVISION 9	52-5	REVISION 9
33-8.....	REVISION 9	52-6	REVISION 9
33-9.....	REVISION 11	56-1	REVISION 9
33-10.....	REVISION 9	56-2	REVISION 9
34-1.....	REVISION 10	73-1	REVISION 9
34-2.....	REVISION 9	73-2	REVISION 9
* 34-3.....	REVISION 12	73-3	REVISION 9
34-4.....	REVISION 11	73-4	REVISION 9
34-5.....	REVISION 11	73-5	REVISION 9
34-6.....	REVISION 10	73-6	REVISION 9
34-7.....	REVISION 10	74-1	REVISION 9
34-8.....	REVISION 10	74-2	REVISION 9
34-9.....	REVISION 11	76-1	REVISION 10
* 34-10.....	REVISION 12	76-2	REVISION 10
34-11.....	REVISION 11	77-1	REVISION 9
34-12.....	REVISION 11	77-2	REVISION 9
* 35-1.....	REVISION 12	78-1	REVISION 9

* Asterisk indicates pages revised, added or deleted by the current revision.

DDPM-145/1116

REVISION 12

LEP	Page C	Code 02
-----	-----------	------------

**DISPATCH
DEVIATIONS
PROCEDURES
MANUAL**



78-2.....	REVISION 9	FERRY-10 ...	REVISION 11
79-1.....	REVISION 9	FERRY-11 ...	REVISION 11
79-2.....	REVISION 9	FERRY-12 ...	REVISION 11
80-1.....	REVISION 9	FERRY-13 ...	REVISION 11
80-2.....	REVISION 9	FERRY-14 ...	REVISION 11
* SPEC-1	REVISION 12	* SDP-1	REVISION 12
SPEC-2	REVISION 9	* SDP-2	REVISION 12
SPEC-3	REVISION 9	* SDP-3	REVISION 12
SPEC-4	REVISION 11	* SDP-4	REVISION 12
SPEC-5	REVISION 11	* SDP-5	REVISION 12
SPEC-6	REVISION 11	* SDP-6	REVISION 12
SPEC-7	REVISION 11	* SDP-7	REVISION 12
SPEC-8	REVISION 11	* SDP-8	REVISION 12
SPEC-9	REVISION 11	* SDP-9	REVISION 12
SPEC-10	REVISION 11	* SDP-10	REVISION 12
* SPEC-11	REVISION 12	* SDP-11	REVISION 12
* SPEC-12	REVISION 12	* SDP-12	REVISION 12
NEF-1.....	REVISION 9	* SDP-13	REVISION 12
NEF-2.....	REVISION 9	* SDP-14	REVISION 12
NEF-3.....	REVISION 9	* SDP-15	REVISION 12
NEF-4.....	REVISION 9	* SDP-16	REVISION 12
NEF-5.....	REVISION 9	* SDP-17	REVISION 12
NEF-6.....	REVISION 9	* SDP-18	REVISION 12
NEF-7.....	REVISION 9		
NEF-8.....	REVISION 9		
NEF-9.....	REVISION 9		
NEF-10.....	REVISION 9		
NEF-11.....	REVISION 9		
NEF-12.....	REVISION 9		
NEF-13.....	REVISION 9		
NEF-14.....	REVISION 9		
FERRY-1.....	REVISION 11		
FERRY-2.....	REVISION 9		
FERRY-3.....	REVISION 11		
FERRY-4.....	REVISION 11		
* FERRY-5.....	REVISION 12		
FERRY-6.....	REVISION 9		
FERRY-7.....	REVISION 11		
FERRY-8.....	REVISION 11		
FERRY-9.....	REVISION 11		

* Asterisk indicates pages revised, added or deleted by the current revision.

LEP	Page D	Code 02
-----	-----------	------------

REVISION 12

TABLE OF CONTENTS

INTRODUCTION

DOCUMENT PURPOSE	1
BACKGROUND	1
DOCUMENT ORGANIZATION	2
USE OF PROCEDURES	2

EICAS MESSAGE LIST

INTRODUCTION	EICAS-1
--------------------	---------

ATA Chapter 21 - AIR CONDITIONING

21-22-04	EXTERNAL GROUND CONNECTOR CHECK VALVE	21-1
21-22-06	BAGGAGE COMPARTMENT VENTILATION SYSTEM	21-1
21-23-03	GASPER FAN	21-2
21-24-01	RECIRCULATION FANS	21-2
21-24-02	RECIRCULATION FAN VALVES	21-2
21-24-03	AIR DISTRIBUTION VALVES	21-3
21-25-01	RAM AIR VALVES	21-4
21-25-02	RAM AIR CHECK VALVES	21-5
21-26-00	FORWARD ELECTRONIC COMPARTMENT VENTILATION SYSTEM	21-5
21-30-00	PRESSURIZATION CONTROL SYSTEM	21-6
21-31-03	OUTFLOW VALVES	21-7
21-32-01	CABIN PRESSURE ACQUISITION MODULE	21-12
21-32-02	CABIN PRESSURE CONTROL SYSTEM HIGH ALTITUDE MODE	21-13
21-51-00	AIR CONDITIONING PACK SYSTEMS	21-13
21-60-04	COCKPIT AUTOMATIC AND MANUAL TEMPERATURE CONTROL SYSTEMS	21-14
21-60-05	CABIN AUTOMATIC AND MANUAL TEMPERATURE CONTROL SYSTEMS	21-15
21-60-06	ATTENDANT'S TEMPERATURE CONTROL	21-16
21-61-02	COCKPIT AND CABIN TEMPERATURE INDICATION SYSTEMS	21-16

DDPM-145/1116

REVISION 9

TOC	Page i	Code 02
-----	-----------	------------



ATA Chapter 22 - AUTOPILOT

22-10-00	AUTOPILOT/FLIGHT DIRECTOR FUNCTIONS	22-1
22-11-01	FLIGHT GUIDANCE CONTROLLER PANEL	22-1
22-11-08	TOUCH CONTROL STEERING BUTTON (TCS SYNC BUTTONS).....	22-2
22-11-09	GO-AROUND BUTTONS.....	22-2

ATA Chapter 23 - COMMUNICATIONS

23-00-00	COMMUNICATIONS SYSTEM (VHF, HF, UHF)	23-1
23-15-00	SATELLITE COMMUNICATION SYSTEM (SATCOM)	23-1
23-20-01	ACARS SYSTEM	23-1
23-21-01	SELECTIVE CALL SYSTEM (SELCAL).....	23-2
23-24-00	CONTROLLER-TO-PILOT DATA LINK (CPDLC)	23-2
23-30-01	PASSENGER ADDRESS SYSTEM.....	23-2
23-31-01	CREWMEMBER INTERPHONE SYSTEM(S)	23-3
23-31-02	ALERTING SYSTEMS (AUDIO/VISUAL).....	23-3
23-31-03	HANDSET SYSTEMS	23-3
23-32-02	PRE-RECORDED PASSENGER ANNOUNCEMENT SYSTEM.....	23-4
23-33-01	PASSENGER CABIN SPEAKERS.....	23-4
23-51-03	PUSH TO TALK (PTT) (BUTTON ON GLARESHIELD PANEL CONTROL WHEEL).....	23-4
23-51-04	FLIGHT DECK SPEAKERS	23-5
23-51-05	FLIGHT DECK HEADSETS	23-5
23-51-07	FLIGHT DECK HANDHELD MICROPHONES.....	23-5
23-70-00	FLIGHTDECK DOOR MONITORING SYSTEM	23-6
23-71-00	COCKPIT VOICE RECORDER SYSTEM.....	23-6
23-73-00	VIDEO SURVEILLANCE SYSTEM (VSS)	23-6
23-80-00	RADIO MANAGEMENT UNITS (RMU'S).....	23-6
23-81-02	TUNING BACKUP CONTROL HEAD	23-7

TOC	Page ii	Code 02
-----	------------	------------

ATA Chapter 24 - ELECTRICAL POWER

24-20-01	GENERATOR CURRENT INDICATIONS	24-1
24-20-02	GENERATOR VOLTAGE INDICATIONS	24-1
24-20-03	INVERTER	24-1
24-31-01	ENGINE DRIVEN GENERATORS.....	24-2
24-31-02	ENGINE DRIVEN GENERATORS BEARINGS (ONLY FOR 30086-11 GENERATOR MODEL)	24-3
24-34-01	APU STARTER GENERATOR	24-4
24-37-00	DC/DC POWER CONVERSION SYSTEM	24-4
24-40-00	EXTERNAL POWER SYSTEM.....	24-4

ATA Chapter 25 - EQUIPMENT AND FURNISHINGS

25-11-00	EYE LOCATOR.....	25-1
25-11-01	FLIGHT CREW SEATS.....	25-1
25-11-02	PRIMARY OBSERVER SEAT (INCLUDING ASSOCIATED EQUIPMENT)	25-2
25-11-04	FLIGHT ATTENDANT SEAT ASSEMBLY	25-2
25-12-01	SUNVISORS	25-3
25-12-02	COCKPIT CONVENIENCE ITEM(S)	25-3
25-12-03	LIGHTED/MECHANICAL CHECKLIST.....	25-3
25-12-04	CHART HOLDERS.....	25-3
25-21-05	PASSENGER SEAT(S).....	25-4
25-22-00	OVERHEAD STORAGE BIN(S)/ CABIN AND GALLEY STORAGE COMPARTMENT/ CLOSETS.....	25-4
25-27-02	LAVATORY BULKHEAD PEEPHOLE	25-5
25-27-09	FORWARD ATTENDANT CONTROL PANEL COVER.....	25-5
25-30-01	GALLEY WASTE RECEPTACLES ACCESS DOORS/COVERS	25-5
25-40-00	EXTERIOR LAVATORY DOOR ASHTRAYS	25-5
25-50-01	CARGO RESTRAINT SYSTEMS	25-6
25-60-02	NON-ESSENTIAL EQUIPMENT AND FURNISHINGS (NEF).....	25-6
25-60-04	LIFE RAFT	25-6
25-60-05	FLIGHT DECK/ATTENDANT FLASHLIGHT AND HOLDER ASSEMBLIES.....	25-7
25-60-06	MEGAPHONES.....	25-7
25-60-07	PYROTECHNIC SIGNAL DEVICES.....	25-7

DDPM-145/1116

REVISION 12

TOC	Page iii	Code 02
-----	-------------	------------

25-60-09	EMERGENCY MEDICAL EQUIPMENT	25-7
25-60-10	"FASTEN SEAT BELTS WHILE SEATED" SIGNS OR PLACARDS.....	25-8
25-61-01	EMERGENCY LOCATOR TRANSMITTER (ELT)	25-8
25-64-02	FLOTATION EQUIPMENT (CREW AND PASSENGER)	25-8

ATA Chapter 26 - FIRE PROTECTION

26-12-00	APU FIRE DETECTION SYSTEM	26-1
26-14-00	LAVATORY SMOKE DETECTION SYSTEM.....	26-1
26-15-00	BAGGAGE COMPARTMENT SMOKE DETECTION SYSTEM	26-2
26-15-10	BAGGAGE COMPARTMENT SMOKE DETECTOR PROTECTIVE BAR	26-2
26-21-02	E1 (2) EXBTBLA (B) INOP CAUTION MESSAGES	26-2
26-22-00	APU FIRE EXTINGUISHING SYSTEM.....	26-4
26-22-01	APU EXBTBL INOP CAUTION MESSAGE.....	26-4
26-23-00	BAGGAGE COMPARTMENT FIRE EXTINGUISHER SYSTEM.....	26-4
26-23-01	PORTABLE FIRE EXTINGUISHER	26-5
26-25-00	LAVATORY FIRE EXTINGUISHER SYSTEMS.....	26-5
26-25-01	GALLEY FIRE EXTINGUISHER SYSTEM	26-6

ATA Chapter 27 - FLIGHT CONTROLS

27-10-01	AILERON DAMPERS	27-1
27-14-00	ROLL TRIM POSITION INDICATION	27-1
27-15-00	AILERON DISCONNECTION LIGHT	27-2
27-21-03	PEDAL ADJUSTMENT MECHANISMS	27-2
27-24-01	YAW TRIM POSITION INDICATIONS	27-4
27-35-00	ELEVATOR DISCONNECTION LIGHT	27-4
27-36-01	SPS/ICE SPEEDS ADVISORY MESSAGE	27-5
27-36-03	STICK SHAKERS	27-5
27-40-00	MAIN PITCH TRIM SWITCHES	27-5
27-40-01	PITCH TRIM POSITION INDICATION	27-6
27-53-00	FLAP CHANNELS	27-7
27-70-00	ELECTRO-MECHANICAL GUST LOCK SYSTEM.....	27-8

TOC	Page iv	Code 02
-----	------------	------------

ATA Chapter 28 - FUEL

28-11-02	SUMP DRAIN VALVES.....	28-1
28-11-05	FUELING RECEPTACLE CAP	28-1
28-21-01	WING TANK ELECTRIC FUEL BOOSTER PUMPS	28-2
28-21-02	WING TANK ELECTRIC FUEL BOOSTER PUMP OPERATING INDICATIONS	28-4
28-22-01	APU FUEL SHUTOFF VALVE	28-5
28-23-00	PRESSURE DEFUELING/REFUELING SYSTEM	28-6
28-23-07	DEFUELING SHUTOFF VALVE	28-9
28-23-08	FUEL QUANTITY INDICATOR (REFUELING PANEL)	28-9
28-40-00	WING TANK FUEL QUANTITY INDICATIONS (EICAS AND MFD)	28-10
28-42-01	DIRECT QUANTITY MEASURING STICKS.....	28-11
28-43-00	FUEL TANK TEMPERATURE INDICATION SYSTEM.....	28-11
28-44-00	FUEL 1 (OR 2) LO LEVEL MESSAGE	28-11
28-45-01	E1 (OR 2) FUEL LO PRESS MESSAGE	28-12
28-45-02	APU FUEL LOW PRESS SWITCH.....	28-13

ATA Chapter 29 - HYDRAULIC POWER

29-10-02	GSE COUPLINGS (EXTERNAL)	29-1
29-10-05	ELECTRIC HYDRAULIC PUMP SYSTEMS	29-2
29-10-14	RESERVOIR REFILLING CHECK VALVES	29-4
29-10-16	PRESSURE GROUND CONNECTION CHECK VALVES	29-5
29-10-19	ENGINE-DRIVEN PUMP PRESSURE SWITCH (HYDRAULIC SYSTEM 1)	29-6
29-30-00	HYDRAULIC FLUID QUANTITY INDICATIONS (INCLUDING LOW LEVEL WARNING)	29-6
29-30-01	RESERVOIR QUANTITY GAGES	29-7
29-30-02	HYDRAULIC PRESSURE INDICATIONS.....	29-9
29-30-04	ELECTRIC PUMP PRESSURE SWITCH (HYDRAULIC SYSTEM 1)	29-10

ATA Chapter 30 - ICE AND RAIN PROTECTION

30-11-00	WING ANTI-ICING SYSTEM.....	30-1
30-11-01	WING ANTI-ICING VALVES	30-2
30-11-02	WING ANTI-ICING VALVE OPEN LIGHT	30-5
30-12-00	STABILIZER ANTI-ICING SYSTEM.....	30-5
30-12-01	STABILIZER ANTI-ICING VALVE	30-5
30-12-02	STABILIZER ANTI-ICING VALVE OPEN LIGHT	30-6
30-21-00	ENGINE ANTI-ICING SYSTEMS	30-6
30-21-01	ENGINE ANTI-ICING VALVES	30-7
30-21-02	ENGINE ANTI-ICING VALVE OPEN LIGHT	30-11
30-31-00	PITOT/STATIC HEATING SYSTEMS.....	30-11
30-31-03	PITOT LINES HEATER	30-12
30-32-01	AOA SENSOR HEATING SYSTEMS	30-12
30-33-01	TAT PROBE HEATING SYSTEMS.....	30-12
30-41-00	WINDSHIELD WIPERS.....	30-12
30-41-04	RAIN REPELLENT COATING	30-13
30-42-02	WINDSHIELD HEATING SYSTEMS.....	30-13
30-80-00	ICE DETECTORS	30-13
30-81-01	CLEAR ICE DETECTOR SYSTEM.....	30-14

TOC	Page vi	Code 02
-----	------------	------------

ATA Chapter 31 - INDICATING/RECORDING SYSTEMS

31-21-01	CLOCKS.....	31-1
31-30-01	FLIGHT DATA RECORDER (FDR) SYSTEM	31-1
31-42-02	INTEGRATED COMPUTER CONFIGURATION MODULES (IM-600).....	31-2
31-51-00	AURAL WARNING UNIT	31-2
31-51-02	MASTER WARNING LIGHTS/BUTTONS	31-2
31-51-03	MASTER CAUTION LIGHTS/BUTTONS.....	31-3

ATA Chapter 32 - LANDING GEAR

32-33-02	LANDING GEAR CONTROL LEVER LATCH SYSTEM.....	32-1
32-40-01	BRAKE TEMPERATURE INDICATIONS	32-2
32-41-08	BRAKE PRESSURE TRANSDUCERS.....	32-4
32-44-05	ACCUMULATOR LOW PRESSURE SWITCH	32-4
32-44-07	BRAKE ON LIGHTS.....	32-5
32-49-00	BRAKE ASSEMBLY WEAR INDICATOR.....	32-6
32-50-00	EXTERNAL STEERING DISENGAGEMENT SWITCH	32-6
32-50-02	CONTROL WHEEL STEERING DISENGAGE BUTTONS	32-7
32-60-00	LANDING GEAR PROXIMITY SWITCHES	32-7

ATA Chapter 33 - LIGHTS

33-10-00	COCKPIT/FLIGHT DECK/FLIGHT COMPARTMENT AND INSTRUMENT LIGHTING SYSTEMS	33-1
33-20-00	CABIN INTERIOR ILLUMINATION SYSTEM	33-1
33-21-02	COCKPIT STERILE LIGHT	33-3
33-23-00	PASSENGER SIGNS	33-3
33-26-00	COURTESY AND STAIRS LIGHTING SYSTEM	33-3
33-30-00	COMPARTMENT LIGHTS (NOSE, TAIL, ETC)	33-4
33-41-00	LANDING LIGHTS	33-4
33-42-00	TAXI LIGHT	33-4
33-43-00	NAVIGATION LIGHTS	33-6
33-44-00	WING INSPECTION LIGHTS	33-8
33-46-00	LOGO LIGHTS	33-8
33-47-03	STROBE LIGHTS	33-8
33-47-05	RED BEACON LIGHTS	33-9
33-48-00	BAGGAGE DOOR EXTERNAL LIGHT	33-9
33-50-00	EMERGENCY LIGHTING SYSTEM (BATTERY POWERED)	33-10
33-50-01	PHOTOLUMINESCENT FLOOR PROXIMITY EMERGENCY ESCAPE PATH MARKING SYSTEM	33-10

ATA Chapter 34 - NAVIGATION

34-22-01	MAIN PANEL DISPLAYS	34-1
34-22-02	TAT INDICATIONS	34-2
34-22-03	SAT INDICATIONS	34-2
34-24-01	STANDBY ATTITUDE INDICATION (ON INTEGRATED STANDBY INSTRUMENT (ISIS) OR ON DEDICATED INSTRUMENT)	34-2
34-24-02	STANDARD BAROMETRIC PRESSURE (STD) BUTTON ON ISIS	34-3
34-25-00	HEAD-UP GUIDANCE SYSTEM (HGS)	34-3
34-25-01	STANDBY MAGNETIC COMPASS	34-3
34-27-00	INERTIAL REFERENCE SYSTEM (IRS)	34-3
34-27-05	IRS MSU ANNUNCIATORS LIGHTS	34-4
34-31-00	RADIO ALTIMETER SYSTEM	34-5
34-31-01	ALTITUDE ALERTER FUNCTION	34-6
34-31-02	ALTITUDE PRESELECT FUNCTION	34-6
34-32-00	VOR/ILS SYSTEMS	34-8
34-41-00	ENHANCED GROUND PROXIMITY WARNING SYSTEM (EGPWS)	34-8
34-41-02	STEEP APPROACH FUNCTION	34-9
34-42-00	WEATHER RADAR SYSTEM	34-9
34-42-01	STORMSCOPE	34-9
34-43-00	TRAFFIC ALERT AND COLLISION AVOIDANCE SYSTEM	34-10
34-51-00	DISTANCE MEASURING EQUIPMENT (DME) SYSTEMS	34-10
34-52-00	ATC TRANSPONDERS AND AUTOMATIC ALTITUDE REPORTING SYSTEMS	34-11
34-53-00	ADF SYSTEM	34-11
34-54-00	XM WEATHER SYSTEM	34-11
34-56-00	GLOBAL POSITIONING SYSTEM	34-12
34-60-00	FLIGHT MANAGEMENT SYSTEM	34-12

ATA Chapter 35 - OXYGEN

35-11-00	OXYGEN PRESSURE INDICATION SYSTEMS	35-1
35-11-03	OXYGEN-CYLINDER PRESSURE RELIEF DISC (GREEN DISC)	35-1
35-20-00	PASSENGER OXYGEN SYSTEM	35-2
35-20-05	PASSENGER OXYGEN SYSTEM DOOR - MANUAL OPENING TOOL	35-2
35-30-01	PORTABLE OXYGEN UNITS (BOTTLE AND MASK)	35-3
35-30-03	PROTECTIVE BREATHING EQUIPMENT (PBE)	35-3

ATA Chapter 36 - PNEUMATIC

36-11-05	ENGINE BLEED SYSTEMS.....	36-1
36-11-10	AIR CONDITIONING PANEL AIR BUTTON RED LEAK INDICATION	36-4
36-12-01	APU BLEED SYSTEM.....	36-5
36-20-00	BLD APU LEAK WARNING MESSAGE.....	36-6

ATA Chapter 38 - WATER/WASTE

38-10-00	WATER SYSTEMS	38-1
38-30-00	LAVATORY WASTE SYSTEMS (INCLUDING WHEELCHAIR ACCESSIBLE LAVATORIES)	38-1

ATA Chapter 45 - CENTRAL MAINTENANCE COMPUTER

45-45-01	CONTROL MAINTENANCE COMPUTER (CMC)	45-1
----------	--	------

ATA Chapter 46 – INFORMATION SYSTEMS

46-20-01	ELECTRONIC FLIGHT BAG SYSTEMS (EFB)	46-1
----------	---	------

ATA Chapter 49 - AIRBORNE AUXILIARY POWER

49-00-00	AUXILIARY POWER UNIT (APU).....	49-1
49-70-01	APU OIL LO PRESS CAUTION MESSAGE	49-2
49-70-02	APU OIL HI TEMP CAUTION MESSAGE.....	49-2
49-70-03	APU FAIL CAUTION MESSAGE	49-2
49-74-01	APU HOURMETER FUNCTION	49-3

TOC	Page X	Code 02
-----	-----------	------------

ATA Chapter 52 - DOORS

52-12-00	MAIN DOOR HYDRAULIC ACTUATION SYSTEM.....	52-1
52-51-00	C&D AEROSPACE FLIGHT DECK SECURITY DOOR.....	52-1
52-70-00	DOOR WARNING SYSTEM (DOOR POSITION INDICATION ON MFD AND EICAS).....	52-2

ATA Chapter 73 - ENGINE FUEL AND CONTROL

73-22-01	ENGINE FULL AUTHORITY DIGITAL ELECTRONIC CONTROL (FADEC) SYSTEM.....	73-1
73-22-02	AUTOMATIC TAKEOFF THRUST CONTROL SYSTEM (ATTCS) (AIRPLANES EQUIPPED WITH A, A1/1, A1 AND A3 ENGINES ONLY)	73-2
73-32-01	ENGINE FUEL TEMPERATURE SENSORS	73-2
73-33-01	E1 (2) FUEL IMP BYP ADVISORY MESSAGES.....	73-3
73-33-02	FUEL FILTERS	73-5
73-40-03	FUEL FLOW INDICATIONS	73-5

ATA Chapter 74 - IGNITION

74-20-00	IGNITION SYSTEM CHANNELS.....	74-1
----------	-------------------------------	------

ATA Chapter 76 - ENGINE CONTROLS

76-12-00	ENGINE TAKEOFF DATA SETTING KNOB SPRING.....	76-1
----------	---	------

ATA Chapter 77 - ENGINE INDICATING

77-41-02	HP VIBRATION INDICATION.....	77-1
----------	------------------------------	------

ATA Chapter 78 - ENGINE EXHAUST

78-30-00	THRUST REVERSERS	78-1
78-34-00	ENG1 (2) REV DISAGREE MESSAGES.....	78-1
78-34-05	IDLE STOP (SOLENOID)	78-2

ATA Chapter 79 - ENGINE OIL

79-32-01	LOW OIL PRESSURE SWITCHES.....	79-1
79-33-01	OIL LEVEL INDICATION SYSTEMS	79-1
79-34-01	OIL PARTICLE SENSORS	79-1
79-35-01	E1 (2) OIL IMP BYP MESSAGES	79-2
79-35-02	OIL FILTERS	79-2

ATA Chapter 80 - STARTING

80-00-00	ENGINE START/STOP SWITCH PROTECTION GUARDS	80-1
80-10-02	STARTER CONTROL VALVES	80-2

MMEL AMENDMENTS FOR SPECIAL OPERATIONS

INTRODUCTION	SPEC OPS-1
CAT II PRECISION APPROACH.....	SPEC OPS-3
HGS AIII MODE PRECISION APPROACH.....	SPEC OPS-6
HGS LOW VISIBILITY TAKEOFF.....	SPEC OPS-7
RVSM.....	SPEC OPS-8
BRNAV/PRNAV/RNAV 5	SPEC OPS-9
RNAV 1/RNAV 2	SPEC OPS-10
ADS-B OUT.....	SPEC OPS-11

NON ESSENTIAL EQUIPMENT AND FURNISHINGS (NEF) LIST

INTRODUCTION	NEF-1
NONESSENTIAL EQUIPMENT AND FURNISHINGS	NEF-2
NEF LIST	NEF-5

FERRY FLIGHT

INTRODUCTION	FERRY-1
FERRY FLIGHT FOR DEACTIVATED SPOILER	FERRY-3
FERRY FLIGHT WITH CREW OXYGEN CYLINDER EMPTY OR WITH LOW PRESSURE.....	FERRY-7
UNPRESSURIZED FERRY FLIGHT	FERRY-11
FERRY FLIGHT WITH PASSENGER ADDRESS SYSTEM AND INTERPHONE SYSTEM INOPERATIVE.....	FERRY-13

TOC	Page xii	Code 02
-----	-------------	------------



DISPATCH DEVIATIONS PROCEDURES MANUAL

TABLE OF
CONTENTS

SPECIAL DISPATCH PROCEDURES

INTRODUCTION	SDP-1
CRACKED OR BROKEN EXTERNAL LIGHTS OR LENSES.....	SDP-3
APPLICATION OF SPEED TAPE	SDP-12
MISSING/DAMAGED BONDING JUMPERS	SDP-17

DDPM-145/1116

REVISION 12

TOC	Page xiii	Code 02
-----	--------------	------------

**DISPATCH
DEVIATIONS
PROCEDURES
MANUAL**



INTENTIONALLY BLANK

TOC	Page XIV	Code 02
-----	-------------	------------

INTRODUCTION

DOCUMENT PURPOSE

This document is intended to assist airline operations and maintenance organizations in developing procedures required to operate the airplane in the various non-standard configurations allowed by the approved Master Minimum Equipment List - MMEL.

- NOTE:** - The symbols, acronyms and terms used in this publication have the same meaning as described under the MMEL Definitions Title.
- In case of conflicting information between this manual and the MMEL, the MMEL must prevail.

BACKGROUND

A MMEL is published for each airplane model, written in very brief format and presenting only the main remarks to dispatch the airplane. In order to accomplish such remarks, it is necessary to establish adequate maintenance and operational procedures, so the airplane may be properly prepared and operated. It is the operator's responsibility to develop a company MEL with procedures, using the MMEL as a guide to obtain approval of this company MEL from the assigned authorities to determine that:

- a) Adequate procedures have been developed, and
- b) The company MEL is not less restrictive than the MMEL.



DOCUMENT ORGANIZATION

This document refers to all the MMEL items by ATA chapter and item title, in the same sequence presented in the MMEL. To avoid duplication of information, and so possible conflicting points, only the maintenance or operational procedures are presented in the DDPM, not the MMEL items. The approved publication to establish the dispatch conditions is the MMEL, which must be referred to defer or not any inoperative pieces of equipment. Page numbering is specific for each ATA chapter, each page number being preceded by the associated ATA chapter number, both presented in the lower external corner of each page. The DDPM page revision date is presented in the lower internal corner of each page. Specific procedures may be not presented either if they are not required by the MMEL, either if they are obvious, either if they depend on operating requirements that may differ from operator to operator.

USE OF PROCEDURES

In conjunction with this document, operators must comply with the MMEL instructions, even though the DDPM procedures and technical guidance are technically correct to the best EMBRAER's knowledge. By publishing this document, EMBRAER is not inferring that the procedures herein presented are the only valid alternatives for the MMEL items. The operator may, in many cases, develop procedures which more closely meet his needs. Variables such as airplane configuration, airline routes, special operational procedures and the own airlines maintenance practices may affect a given procedure. Because of the above explained, it is emphasized that the information contained in this publication is presented for guidance purposes only. Before publishing any dispatch procedure in its own manual, each operator should review the procedures, to assure that they are adequate for his particular operation, and should submit them to the local authority inspector, if any.

INTRO	Page 2	Code 02
-------	-----------	------------

EICAS MESSAGE LIST

INTRODUCTION

The main purpose of the EICAS Message List is to provide a quick means to cross-reference an EICAS Message with the possible associated MMEL/MEL item. This EICAS Message List is intended to assist operators in defining if the condition presented by the message is a deferrable one or not.

It is not the intent of this list to replace or disregard proper troubleshooting of the associated EICAS Messages.

Whenever an EICAS Message is displayed, its cause must be investigated by using the appropriate means, such as the Fault Isolation Manual (FIM) or associated maintenance procedures. Only after the proper identification of the failed component that an MMEL/MEL relief may be used.

The list presents all EICAS Messages that may be related to a system failure. Thus, EICAS Messages which has only status information is not contained in this list.

This list presents the EICAS Messages according to the following classification:

- TYPE: Indicates whether the message is classified as Warning (W), Caution (C) or Advisory (A);
- MESSAGE: Provide the EICAS Messages on alphabetical order;
- POSSIBLE FAILED COMPONENTS: Among all possible failure causes related to the EICAS message, only those for which a relief is predicted upon the MMEL/MEL application is listed. For all remaining failure modes for which no MMEL/MEL relief is granted, a dash sign ("-") is used;
- REFER TO: Indicates the MMEL/MEL item number associated to the possible failed components, if applicable. When no relief is granted in the MMEL/MEL, the "NO DISP" inscription identifies a no dispatch condition. The "not applicable" (N/A) indicates that the EICAS message is not related to a system failure condition.

**DISPATCH
DEVIATIONS
PROCEDURES
MANUAL**

- **REMARKS:** Presents further information on the cause of the EICAS message, whether it is an actual message or a spurious one. The spurious message is identified by a “false” inscription and means that the failure condition displayed by the EICAS message is not present, usually associated to a failure of a monitoring function.

EICAS	Page 2	Code 02
-------	-----------	------------

TYPE	MESSAGE	POSSIBLE FAILED COMPONENTS	REFER TO	REMARKS
C	115 V AC BUS OFF	AC Static Inverter	MMEL 24-20-03	-
		Other failures	NO DISP	-
C	A/ICE LOW CAPACITY	-	N/A	-
C	A/ICE SWITCH OFF	Other failures	NO DISP	-
		Wing Anti-Icing Pushbutton	MMEL 30-11-00	-
		Stab Anti-Icing Pushbutton	MMEL 30-12-00	-
		Engine Air Inlet Anti-Icing Pushbutton	MMEL 30-21-00	-
C	ACCESS DOORS OPN	Door Warning Microswitches	MMEL 52-70-00	False Caution
		Door Actuating and Locking Mechanism	NO DISP	Actual Caution
A	AHRS 1(2) ALN	-	N/A	AHRS 1 is in the alignment mode
C	AHRS 1(2) ALN FAULT	-	NO DISP	-
A	AHRS 1(2) ATT MODE	-	NO DISP	-
A	AHRS 1(2) BASIC MODE	-	NO DISP	-
A	AHRS 1(2) EXC MOTION	-	N/A	Maintain A/C stationary during AHRS alignment
C	AHRS 1(2) FAIL	-	NO DISP	-
A	AHRS 1(2) NO MAG HDG	-	N/A	AHRS must be initialized with magnetic heading

**DISPATCH
DEVIATIONS
PROCEDURES
MANUAL**



TYPE	MESSAGE	POSSIBLE FAILED COMPONENTS	REFER TO	REMARKS
A	AHRS 1(2) NO PPOS	-	N/A	Present position not entered
A	AHRS 1(2) ON BATT	-	NO DISP	-
C	AHRS 1(2) OVERHEAT	-	NO DISP	-
A	AIII NOT AVAIL	-	N/A	-
C	AIL SYS 1 INOP	-	NO DISP	-
C	AIL SYS 2 INOP	-	NO DISP	-
C	AOA 1(2) HEAT INOP	AOA Heater Sensor	MMEL 30-32-01	-
C	AP AIL MISTRIM	Roll Trim Actuator Autopilot	NO DISP MMEL 22-10-00	- -
C	AP ELEV MISTRIM	Elevator Actuator Autopilot	NO DISP MMEL 22-10-00	- -
C	APU BLD VLV FAIL	APU Bleed System	MMEL 36-12-01	-
C	APU CNTOR CLSD	APU Starter Contactor	MMEL 24-34-01	-
C	APU EXTBTL INOP	APU EXTBTL INOP Message	MMEL 26-22-00	Actual Caution
		APU EXTBTL INOP Message	MMEL 26-22-01	False Caution
C	APU FAIL	APU	MMEL 49-00-00	Actual Caution
		APU FAIL message	MMEL 49-70-03	False Caution
C	APU FIREDET FAIL	APU Fire Detection System	MMEL 26-12-00	-
C	APU FUEL LO PRESS	APU System	MMEL 49-00-00	-
		APU Fuel Low Press Switch	MMEL 28-45-02	-
		Other failures	NO DISP	-

DDPM-145/1116

TYPE	MESSAGE	POSSIBLE FAILED COMPONENTS	REFER TO	REMARKS
C	APU FUEL SOV INOP	APU Shut-off Valve	MMEL 28-22-01	-
C	APU GEN OFF BUS	APU Starter Generator	MMEL 24-34-01	-
C	APU GEN OVLD	APU Starter Generator	MMEL 24-34-01	-
C	APU OIL HI TEMP	APU Oil System	MMEL 49-70-02	False Caution
		APU	MMEL 49-00-00	Actual Caution
C	APU OIL LO PRESS	APU Oil System	MMEL 49-70-01	False Caution
		APU	MMEL 49-00-00	Actual Caution
W	ATTCS FAIL	A, A1, A1/1 and A3	73-22-02	-
		Others engines	NO DISP	-
C	AURAL WARN FAIL	-	NO DISP	-
C	AUTO TRIM FAIL	Other failures	NO DISP	-
		Autopilot	MMEL 22-10-00	-
W	AUTOPILOT FAIL	Autopilot	MMEL 22-10-00	-
C	BAGG EXTBTL INOP	Baggage Compartment Fire Extinguisher System	MMEL 26-23-00	-
C	BAGGAGE DOOR OPN	Door Warning Microswitches	MMEL 52-70-00	False Warning
		Door Actuating and Locking Mechanism	NO DISP	Actual Warning
C	BATT 1(2) OFF BUS	-	NO DISP	-
W	BATT 1(2) OVTEMP	-	NO DISP	-
C	BKUP BATT OFF BUS	-	NO DISP	-
W	BLD 1(2) LEAK	-	NO DISP	-

**DISPATCH
DEVIATIONS
PROCEDURES
MANUAL**



TYPE	MESSAGE	POSSIBLE FAILED COMPONENTS	REFER TO	REMARKS
C	BLD 1(2) LOW TEMP	Engine Bleed Systems	MMEL 36-11-05	-
		Other failures	NO DISP	-
W	BLD 1(2) OVTEMP	Engine Bleed Systems	MMEL 36-11-05	-
		Other failures	NO DISP	-
A	BLD 1(2) VLV CLSD	Engine Bleed Valve	MMEL 36-11-05	-
		Other failures	NO DISP	-
C	BLD 1(2) VLV FAIL	Engine Bleed Valve	MMEL 36-11-05	-
		Other failures	NO DISP	-
W	BLD APU LEAK	APU Bleed System	MMEL 36-12-01	Actual Warning
		BLD APU LEAK message	36-20-00	False Warning
C	BRAKE DEGRADED	Brake Pressure Transducer	MMEL 32-41-08	-
		Other failures	NO DISP	-
C	BRAKE OVERHEAT	-	NO DISP	-
C	BRK INBD INOP	-	NO DISP	-
C	BRK OUTBD INOP	-	NO DISP	-
W	CHECK ACFT LOAD	CHECK ACFT LOAD message	MMEL 28-45-06	False Warning
C	CHECK IC 1 SW	-	NO DISP	-
C	CHECK IC 2 SW	-	NO DISP	-
C	CHECK PFD 1 (2)	Main Panel Display	MMEL 34-22-01	Perform Display swap
		Other failures	NO DISP	-
A	CHECKLST MISMATCH	-	NO DISP	-
C	CHK IC CONFIG	-	NO DISP	-
A	CONFIG MISMATCH	-	NO DISP	-
C	CROSS BLD FAIL	-	NO DISP	-

TYPE	MESSAGE	POSSIBLE FAILED COMPONENTS	REFER TO	REMARKS
C	CROSS BLD SW OFF	-	N/A	Cross Bleed is OFF
		Cross Bleed Switch	NO DISP	-
C	DAU 1 A FAIL	-	NO DISP	-
A	DAU 1 B FAIL	-	NO DISP	-
C	DAU 1 ENG MISCMP	-	NO DISP	-
A	DAU 1 REVERSION	-	NO DISP	-
C	DAU 1 SYS MISCMP	-	NO DISP	-
C	DAU 1 WRN MISCMP	-	NO DISP	-
C	DAU 2 A FAIL	-	NO DISP	-
A	DAU 2 B FAIL	-	NO DISP	-
C	DAU 2 ENG MISCMP	-	NO DISP	-
A	DAU 2 REVERSION	-	NO DISP	-
C	DAU 2 SYS MISCMP	-	NO DISP	-
C	DAU 2 WRN MISCMP	-	NO DISP	-
C	DAU AC ID MISCMP	-	NO DISP	-
C	DC BUS 1(2) OFF	-	NO DISP	-
C	DFDR FAIL	Failure of Flight Data Recorder (FDR) System	M MEL 31-30-01	-
		Other failures	NO DISP	-
A	DU 1(2,3,4,5) FAN FAIL	Display Unit Fan	M MEL 34-22-01	DU is de-activated
A	DU 1(2,3,4,5) OVHT	Display Unit	M MEL 34-22-01	DU is de-activated
A	E1 HYD PUMP FAIL	Pressure Switch of EDP	M MEL 29-10-19	-
		Engine Driven Pump	NO DISP	-
C	E1(2) A/ICE FAIL	ENG 1 A/ICE System	M MEL 30-21-00	-
		ENG 1 A/ICE Valve	M MEL 30-21-01	-
C	E1(2) ATS SOV OPN	Starter Control Valve	M MEL 80-10-02	-
		Other failures	NO DISP	-

DDPM-145/1116

**DISPATCH
DEVIATIONS
PROCEDURES
MANUAL**



TYPE	MESSAGE	POSSIBLE FAILED COMPONENTS	REFER TO	REMARKS
W	E1(2) ATTCS NO MRGN	-	NO DISP	-
C	E1(2) CTL FAIL	-	NO DISP	-
C	E1(2) EXCEEDANCE	-	NO DISP	-
C	E1(2) EXBTBLA(B) INOP	E1(2) EXBTBLA(B) INOP Message	MMEL 26-21-02	False Caution
		Other failures	NO DISP	-
C	E1(2) FIREDET FAIL	-	NO DISP	-
C	E1(2) FPMU NO DISP	-	NO DISP	-
A	E1(2) FUEL IMP BYP	Electrical/Mechanical Impending Bypass Indicator	MMEL 73-33-01	False Advisory
		Fuel Imp Bypass	MMEL 73-33-02	Actual Advisory
C	E1(2) FUEL LO PRESS	Wing Tank Electric Fuel Booster Pumps	MMEL 28-21-01	Actual Caution
		E1 (2) FUEL LO PRESS message	MMEL 28-45-01	False Caution
C	E1(2) FUEL LO TEMP	-	NO DISP	-
C	E1(2) FUEL SOV INOP	-	NO DISP	-
A	E1(2) IDL STP FAIL	Engine Idle Lock Solenoid	MMEL 78-34-05	-
W	E1(2) LOW N1	-	NO DISP	-
C	E1(2) NO DISP	FADEC fault	73-22-01	-
A	E1(2) OIL IMP BYP	Oil Filter Element	MMEL 79-35-02	Actual Advisory
		Oil-Filter Impending-Bypass Switch	MMEL 79-35-01	False Advisory
W	E1(2) OIL LOW PRESS	Low-Oil-Pressure Sensor (Switch)	MMEL 79-32-01	False Warning
		Actual Low Oil Press	NO DISP	-
A	E1(2) SHORT DISP	FADEC fault	MMEL 73-22-01	-
A	E1(2) HYD PUMP FAIL	-	NO DISP	-
C	ELEC EMERG ABNORMAL	-	NO DISP	-
W	ELEC ESS XFR FAIL	-	NO DISP	-
C	ELEKBAY OVTEMP	-	NO DISP	-

DDPM-145/1116

TYPE	MESSAGE	POSSIBLE FAILED COMPONENTS	REFER TO	REMARKS
C	EMERG EXIT OPN	Hatch Microswitches	MMEL 52-70-00	False Caution
		Hatch Locking Mechanism	NO DISP	Actual Caution
C	EMERG LT NOT ARMD	-	N/A	-
C	EMRG BRK LO PRES	Accumulator Low Pressure Switch	MMEL 32-44-05	-
		Other failures	NO DISP	
C	ENG 1(2) REV DISAGREE	Thrust Reverser System	MMEL 78-30-00	-
C	ENG 1(2) REV FAIL	Other failures	MMEL 78-30-00	-
		FADEC TR Interface	NO DISP	-
A	ENG A/ICE OVERPRES	ENG 1 A/ICE System	MMEL 30-21-00	-
		ENG 1 A/ICE Valve	MMEL 30-21-01	-
W	ENG ATTCS FAIL	ATTCS	MMEL 73-22-02	-
C	ENG NO TO DATA	-	NO DISP	-
C	ENG REF A/I DISAG	-	N/A	-
W	ENG1 (2) OUT	-	NO DISP	-
C	ENG1 OUT	-	NO DISP	-
C	ENG2 OUT	-	NO DISP	-
C	ENG1(2) TLA FAIL	-	NO DISP	-
C	ESS BUS 1(2) OFF	-	NO DISP	-
C	FADEC ID NO DISP	-	NO DISP	-
A	FDAU FAIL	Flight Data Acquisition Unit/Auxiliary Flight Data Acquisition and Management Unit (AFDAU/AFDAMU)	MMEL 31-30-01	-
C	FLAP FAIL	-	NO DISP	-

**DISPATCH
DEVIATIONS
PROCEDURES
MANUAL**



TYPE	MESSAGE	POSSIBLE FAILED COMPONENTS	REFER TO	REMARKS
A	FLAP LOW SPEED	Flap Channel	MMEL 27-53-00	-
W	FUEL LO LEVEL	FUEL LO LEVEL message	MMEL 28-44-00	False Warning
C	FUEL TK VENT OPEN	FUEL TK VENT OPEN message	MMEL 28-14-00	False Caution
		Forward Auxiliary Tank Vent Valve	MMEL 28-45-10	False Caution
		Aft Auxiliary Tank Vent Valve	MMEL 28-45-16	False Caution
		Ventral Tank Vent Valve	MMEL 28-45-17	Actual Caution
C	FUEL XFEED FAIL	-	NO DISP	-
C	FUEL XFER 1(2) INOP	FUEL XFER 1(2) message	MMEL 28-45-12	False Caution
W	FUEL XFER CRITICAL	FUEL XFER CRITICAL message	MMEL 28-45-13	False Warning
C	FUEL XFR VTR INOP	FUEL XFR VTR INOP message	MMEL 28-45-15	False Caution
C	FUELING DOOR OPN	Panel Switch Electrical Circuit	MMEL 52-70-00	False Caution
		Panel Locking Mechanism	NO DISP	Actual Caution
C	FUSELAGE FUEL IMB	FUSELAGE FUEL IMB message	MMEL 28-45-05	False Caution
A	GEN 1(2,3,4) BRG FAIL	Engine Driven Generator Bearings	MMEL 24-31-02	-
		Engine Driven Generator	MMEL 24-31-01	-
C	GEN 1(2,3,4) OFF BUS	Engine Driven Generator	MMEL 24-31-01	-
C	GEN 1(2,3,4) OVLD	Engine Driven Generator	MMEL 24-31-01	-
		APU Starter Generator	MMEL 24-34-01	-
C	GPWS INOP	GPWS/Windshear Computer	MMEL 34-41-00	-
C	HGS FAIL	HGS	MMEL 34-25-00	-

DDPM-145/1116

TYPE		POSSIBLE FAILED COMPONENTS	REFER TO	REMARKS
	MESSAGE			
C	HS VLV 1(2) FAIL	High Stage Valve	MMEL 36-11-05	-
		High Stage Pressure Switch	MMEL 36-11-05	-
A	HYD 1(2) LO QTY	Level in the reservoir of hydraulic system 1 is low	NO DISP	-
		Reservoir Quantity Indicator	MMEL 29-30-00	-
A	HYD PUMP SELEC OFF	-	N/A	-
C	HYD SYS 1(2) FAIL	-	NO DISP	-
C	HYD SYS 1(2) OVHT	-	NO DISP	-
A	IC 1 FAN FAIL	-	NO DISP	-
C	IC 1 OVERHEAT	-	NO DISP	-
A	IC 1(2) CONFIG FAIL	IC-600 Configuration Module (IM-600)	MMEL 31-42-02	-
		Other failures	NO DISP	-
C	IC 1(2) WOW INOP	-	NO DISP	-
A	IC 2 FAN FAIL	-	NO DISP	-
C	IC 2 OVERHEAT	-	NO DISP	-
C	IC BUS FAIL	-	NO DISP	-
W	ICE COND - A/I INOP	Eng Start Aux Relay or Air/Ground Relay	NO DISP	-
C	ICE DET 1(2) FAIL	Ice Detector	MMEL 30-80-00	-
		Other failures	NO DISP	-
C	ICE DETECTORS FAIL	Ice Detector	MMEL 30-80-00	-
		Other failures	NO DISP	-
A	ICE/SPS ADVANCED, SPS/ICE SPEEDS	ICE/SPS ADVANCED, SPS/ICE SPEEDS message	MMEL 27-36-01	-
A	IRS 1(2) ALN	-	N/A	IRS in the alignment mode
C	IRS 1(2) ALN FAULT	-	MMEL 34-27-00	-

DDPM-145/1116

**DISPATCH
DEVIATIONS
PROCEDURES
MANUAL**



TYPE		POSSIBLE FAILED COMPONENTS	REFER TO	REMARKS
	MESSAGE			
A	IRS 1(2) ATT MODE	-	MMEL 34-27-00	-
A	IRS 1(2) EXC MOTION	-	N/A	A/C not stationary during IRS alignment
C	IRS 1(2) FAIL	-	MMEL 34-27-00	-
A	IRS 1(2) NO MAG HDG	-	N/A	-
A	IRS 1(2) NO PPOS	-	N/A	-
A	IRS 1(2) ON BATT	-	N/A	-
C	IRS 1(2) OVERHEAT	-	NO DISP	-
W	LG / LEVER DISAGREE	-	NO DISP	-
C	LG AIR/GND FAIL	-	NO DISP	-
W	MAIN DOOR OPN	Door Warning Microswitches	MMEL 52-70-00	False Warning
		Door Actuating and Locking Mechanism	NO DISP	Actual Warning
C	NLG UP/DOOR OPN	-	NO DISP	-
C	NO ICE - A/ICE ON	-	N/A	Actual Caution
		Wing anti-icing valve	MMEL 30-11-01	False Caution
		Stab anti-icing valve	MMEL 30-12-01	False Caution
		Engine air inlet anti-icing valve	MMEL 30-21-01	False Caution
W	NO TAKEOFF CONFIG	-	NO DISP	-
C	OXYGEN LO PRESS	Oxygen Pressure Transducer	MMEL 35-11-00	-
		Other failures	NO DISP	-
C	PACK 1(2) OVHT	Air Conditioning Pack Systems	MMEL 21-51-00	-
		Other failures	NO DISP	-

DDPM-145/1116

TYPE		POSSIBLE FAILED COMPONENTS	REFER TO	REMARKS
	MESSAGE			
C	PACK 1(2) OVLD	Air Conditioning Pack Systems	MMEL 21-51-00	-
		Other failures	NO DISP	-
A	PACK 1(2) VLV CLSD	Air Conditioning Pack Systems	MMEL 21-51-00	False Advisory
		-	N/A	Actual Advisory
C	PACK 1(2) VLV FAIL	Engine Bleed Valve	MMEL 36-11-05	In case Pack Valve Fails Open
		Pack Valve	MMEL 21-51-00	-
W	PIT TRIM 1 INOP, PTRIM MAIN INOP	-	NO DISP	-
W	PIT TRIM 2 INOP, PTRIM BACKUP INOP	-	NO DISP	-
C	PITOT 1 (2) INOP	-	MMEL 30-31-00	-
C	PITOT 3 INOP	-	NO DISP	-
C	PRESN AUTO FAIL	Pressurization Control System	MMEL 21-30-00	-
		Electropneumatic Outflow Valve	MMEL 21-31-03	-
		Other failures	NO DISP	-
C	PTRIM BKP SW FAIL	-	NO DISP	-
C	PTRIM CPT SW FAIL	-	MMEL 27-40-00	-
C	PTRIM F/O SW FAIL	-	MMEL 27-40-00	-
A	RAD ALT 1(2) FAIL	Radio Altimeter	MMEL 34-31-00	-
A	RAD ALT FAIL	Radio Altimeter	MMEL 34-31-00	-
C	RAM AIR VLV FAIL	Ram Air Valves	MMEL 21-25-01	-
		RH (LH) Pack Valve	MMEL 21-51-00	-

DDPM-145/1116

**DISPATCH
DEVIATIONS
PROCEDURES
MANUAL**



TYPE	MESSAGE	POSSIBLE FAILED COMPONENTS	REFER TO	REMARKS
C	ROLL LEFT(RIGHT) MISTRIM	Roll Trim Actuator	NO DISP	-
		Autopilot	MMEL 22-10-00	-
C	RUDDER HARDOVER PROT FAIL	-	NO DISP	-
C	RUDDER OVERBOOST	-	NO DISP	-
C	RUDDER SYS 1 INOP	-	NO DISP	-
C	RUDDER SYS 1-2 INOP	-	NO DISP	-
C	RUDDER SYS 2 INOP	-	NO DISP	-
W	SERVICE DOOR OPN	Door Warning Microswitches	MMEL 52-70-00	False Warning
		Door Actuating and Locking Mechanism	NO DISP	Actual Warning
C	SHED BUS 1(2) OFF	-	NO DISP	-
C	SPBK LVR DISAGREE	-	NO DISP	-
C	SPOILER FAIL	-	NO DISP	-
W	SPS 1 INOP	-	NO DISP	-
W	SPS 1-2 INOP	-	NO DISP	-
W	SPS 2 INOP	-	NO DISP	-
C	SPS ADVANCED	-	NO DISP	-
C	STAB A/ICE FAIL	STAB A/ICE System	MMEL 30-12-00	-
		STAB A/ICE VLV	MMEL 30-12-01	-
C	STEER INOP	External disengagement switch	MMEL 32-50-00	-
		-	NO DISP	-
C	STICK PUSHER FAIL	-	NO DISP	-
C	TAT 1(2) HEAT INOP	TAT Heater System	MMEL 30-33-01	-

C	TERR INOP	FMS	MMEL 34-60-00	-
		GPWS/Windshear Computer	MMEL 34-41-00	-
		Other failures	NO DISP	-
C	W/S 1(2) HEAT FAIL	W/S Heating System	MMEL 30-42-02	-
				-
C	WG 1(2) A/ICE FAIL	Wing A/ICE System	MMEL 30-11-00	-
		Wing A/ICE Valve	MMEL 30-11-01	-
C	WG A/ICE ASYMETRY	Wing A/ICE Valve	MMEL 30-11-01	-
C	WG A/ICE FAIL	WING A/ICE System	MMEL 30-11-00	-
		Wing A/ICE Valve	MMEL 30-11-01	-
C	WINDSHEAR INOP	GPWS/Windshear Computer	MMEL 34-41-00	-
		Other failures	NO DISP	-
C	YAW DAMPER FAIL	Yaw Damper	MMEL 22-10-00	-

**DISPATCH
DEVIATIONS
PROCEDURES
MANUAL**



INTENTIONALLY BLANK

EICAS	Page 16	Code 02
-------	------------	------------

REVISION 10

DDPM-145/1116

ATA CHAPTER 21 AIR CONDITIONING

21-22-04 EXTERNAL GROUND CONNECTOR CHECK VALVE

Placard Air Conditioning/Pneumatic Panel "GROUND CONNECTION CHECK VALVE OPEN".

OPERATIONAL PROCEDURES

Refer to item 21-31-03 for unpressurized configuration.

MAINTENANCE PROCEDURES

Refer to item 21-31-03 for outflow valves secured open, if required.

21-22-06 BAGGAGE COMPARTMENT VENTILATION SYSTEM

Placard Fire Detection/Extinguishing Panel "VENTILATION SYSTEM INOP".

OPERATIONAL PROCEDURES

None.

MAINTENANCE PROCEDURES

Alternate method (below) may be flight crewmember accomplished.

Deactivate Baggage Recirculation Fan as follows:

- On the circuit breaker panel, open the MISCELLANEOUS/ BAGGAGE RECIRC FAN circuit breaker and attach a do-not-close tag on it.
- Open access 272DR, Rear Electronic Compartment Access Hatch. Gain access to the rear electronic compartment and locate the baggage recirculation fan (See Figure on AMM PART I 21-27-00).
- Disconnect and stow electrical connector of the fan.
- Close BAGGAGE RECIRC FAN circuit breaker.

An alternate method to deactivate baggage compartment fan is pulling and collaring BAGGAGE RECIRC FAN circuit breaker. The Baggage Fire Extinguishing Button will not illuminate during system test, however EICAS message BAGG SMOKE and extinguishing system will remain operate normally.



21-23-03 GASPER FAN

Placard Gasper Fan Button "INOP".

OPERATIONAL PROCEDURES

None.

MAINTENANCE PROCEDURES

May be flight crewmember accomplished. Pull and safety gasper fan circuit breaker (F25).

21-24-01 RECIRCULATION FANS

Placard Recirculation Button "INOP".

OPERATIONAL PROCEDURES

None.

MAINTENANCE PROCEDURES

Recirculation Fan deactivated:

May be flight crewmember accomplished. Pull and safety the affected recirculation fan circuit breaker, COCKPIT RECIRC (J14) and/or CABIN RECIRC (J21).

21-24-02 RECIRCULATION FAN VALVES

Placard Air Conditioning/Pneumatic Control Panel "RECIRCULATION FAN VALVE OPEN".

OPERATIONAL PROCEDURES

None.

MAINTENANCE PROCEDURES

- Perform SUBTASK 21-20-00-710-001-A00 (AMM) for recirculation fan operational check.
- Refer to Item 21-24-01 for recirculation fan deactivation.

1-09-21	Page 2	Code 02
---------	-----------	------------



DISPATCH DEVIATIONS PROCEDURES MANUAL

ATA CHAPTER 21
AIR CONDITIONING

21-24-03 AIR DISTRIBUTION VALVES

Placard Air Conditioning/Pneumatic Control Panel "AIR DISTRIBUTION VALVE STUCK CLOSED".

OPERATIONAL PROCEDURES

None.

MAINTENANCE PROCEDURES

May be flight crewmember accomplished.

Perform TASK 21-22-01-040-801-A (AMM) for air distribution valve deactivation.

DDPM-145/1116

REVISION 11

1-09-21	Page 3	Code 02
---------	-----------	------------



21-25-01 RAM AIR VALVES

Placard affected Air Conditioning Pack Button "INOP".

OPERATIONAL PROCEDURES

Failure of One Ram Air Valve:

Conduct flight at or below 25000 ft. Associated Air Conditioning Pack must be OFF.

Failure of Both Ram Air Valves:

Conduct flight at or below 10000 ft. Both Air Conditioning Packs must be OFF. Refer to Item 21-31-03 for unpressurized configuration.

MAINTENANCE PROCEDURES

Perform TASK 21-25-01-040-801-A (AMM) for ram air valve deactivation.

1-09-21	Page 4	Code 02
---------	-----------	------------



DISPATCH DEVIATIONS PROCEDURES MANUAL

ATA CHAPTER 21
AIR CONDITIONING

21-25-02 RAM AIR CHECK VALVES

Placard Air Conditioning/Pneumatic Control Panel "RAM AIR INOP OPEN".

OPERATIONAL PROCEDURES

Refer to Item 21-31-03 for unpressurized configuration.

MAINTENANCE PROCEDURES

Refer to Item 21-31-03 for outflow valves secured open, if required.

21-26-00 FORWARD ELECTRONIC COMPARTMENT VENTILATION SYSTEM

Placard Air Conditioning/Pneumatic Control Panel "FWD ELEC COMPT VENT INOP".

OPERATIONAL PROCEDURES

None.

MAINTENANCE PROCEDURES

None.

DDPM-145/1116

REVISION 9

1-09-21	Page 5	Code 02
---------	-----------	------------

21-30-00 PRESSURIZATION CONTROL SYSTEM

Placard Pressurization Mode Selector Button "MAN INOP", or "AUTO INOP", or "AUTO/MAN INOP".

OPERATIONAL PROCEDURES

Operation in Manual Mode:

If automatic control of the pressurization system is not possible, manual control of cabin pressure can be maintained via the pneumatic outflow valve using the following procedures:

- Rotate the Manual Pressurization knob clockwise to FULL UP position.
- Select MAN with the guarded pressurization mode selector button.
- Rotate the knob clockwise to increase cabin altitude, rotate it counter-clockwise to decrease cabin altitude.
- Monitor cabin differential pressure to ensure it remains within limits.

Operation in Automatic Mode:

If manual control of the pressurization system is not possible, automatic control of cabin pressure can be maintained via the electropneumatic outflow valve monitoring cabin differential pressure to ensure it remains within limits.

Unpressurized Configuration:

Refer to either the Operational or Maintenance procedure under item 21-31-03, for electropneumatic/pneumatic outflow valves secured open.

MAINTENANCE PROCEDURES

Refer to Item 21-31-03 for electropneumatic/pneumatic outflow valves secured closed or secured open.

NOTE: For outflow valves secured open procedure on item 21-31-03, the airplane may be dispatched after either the operational procedure or the maintenance procedure is accomplished (only one of both is required to be performed).

21-31-03 OUTFLOW VALVES

Placard Pressurization Mode Selector Button "MAN INOP" if pneumatic outflow valve is inoperative, or "AUTO INOP" if electropneumatic outflow valve is inoperative, or "AUTO/MAN INOP" if both outflow valves are inoperative.

NOTE: In case of pressurization static port heating inoperative, the airplane may be dispatched by this item.

OPERATIONAL PROCEDURES

Unpressurized Configuration:

- Outflow Valves OPEN
 - Outflow valves may be kept open through one of the following ways:
 - Pressurization Dump Button PRESSED
 - OR
 - Pressurization Mode Selector Button PRESSED
 - Manual Controller Knob UP
 - OR
 - Using the Opening Tool Kit (refer to maintenance procedures).
 - OR
 - Removing the valves.

NOTE: For flight in unpressurized configuration, the airplane may be dispatched after either the operational procedure or the maintenance procedure to secure both outflow valves open is accomplished (only one of both is required to be performed).

- Bleed Air Buttons AS REQUIRED
 - If air conditioning packs are going to be used, maintain the Bleed Air Buttons at pressed position (bleed open), otherwise, set them to released position (bleed closed).

- Pack Buttons AS REQUIRED
 - If air conditioning packs are going to be used, maintain the Pack Buttons at pressed position (pack valve open), otherwise, set them to released position (pack valve closed).

- Recirculation Fans AS REQUIRED
- Altitude 10000 FT



MAINTENANCE PROCEDURES

Electropneumatic Outflow Valve Secured Closed:

- Gain access to the electropneumatic outflow valve located in the rear pressure bulkhead.
- Perform AMM TASK 21-31-03-000-801-A to remove the electropneumatic outflow valve.
- Safety the valve in the closed position, as shown in outflow valves figure.
- Open fitting 1 (see outflow valves figure) and plug tube and valve with plugs P/N AN 806-D5 and P/N AN 929-5.
- Perform AMM TASK 21-31-03-400-801-A to install the electropneumatic outflow valve.
- Install removed access panel.

Pneumatic Outflow Valve Secured Closed:

- Gain access to the pneumatic outflow valve located in the rear pressure bulkhead.
- Perform AMM TASK 21-31-04-000-801-A to remove the pneumatic outflow valve.
- Safety the valve in the closed position, as shown in outflow valves figure.
- Open fitting 2, 3 and 4 (see outflow valves figure) and plug tubes and valve with plugs P/N AN 806-D5 and P/N AN 929-5.
- Perform AMM TASK 21-31-04-400-801-A to install the pneumatic outflow valve.
- Install removed access panel.

1-09-21	Page 8	Code 02
---------	-----------	------------

ELECTROPNEUMATIC
 OR PNEUMATIC
 OUTFLOW VALVE

LOCKWIRE

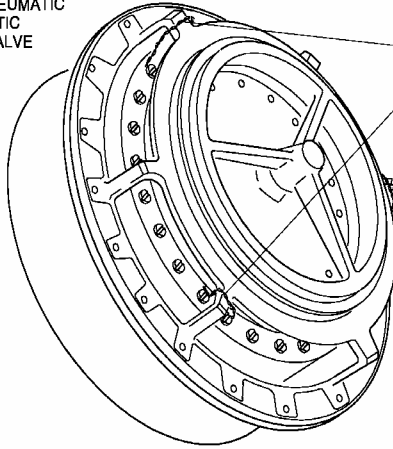

PNEUMATIC OUTFLOW
 VALVE

ELECTROPNEUMATIC
 OUTFLOW VALVE

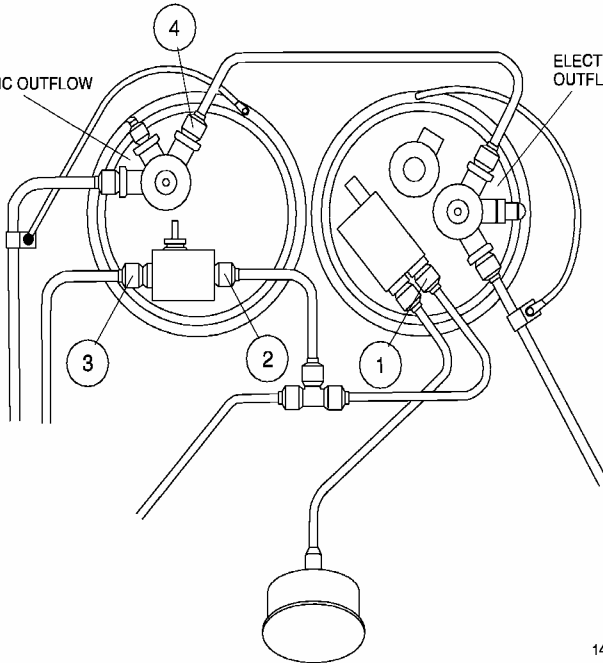

145DDPM090002.MCE

OUTFLOW VALVES

DDPM-145/1116

REVISION 9

1-09-21	Page 9	Code 02
---------	-----------	------------



Both Outflow Valves Secured Open (if applicable):

- Gain access to the both outflow valves located in the rear pressure bulkhead.
- Using both hands, open one of the valves by pressing the poppet and insert the opening tool (GSE 282) so as to fit it in the valve axle guide (see Outflow Valve Secured Open figure).
- Assure the opening tool is fitted on the axle in order to avoid valve closing.
- Repeat the procedure for the remaining outflow valve.

NOTE: To remove the Opening Tool from the valve assembly, just pull it out.

1-09-21	Page 10	Code 02
---------	------------	------------

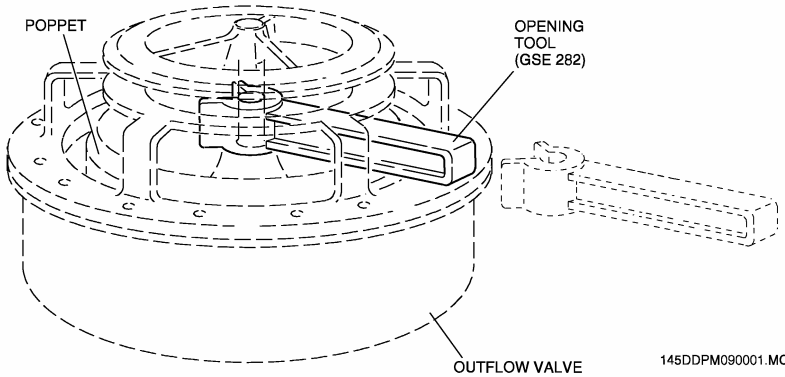
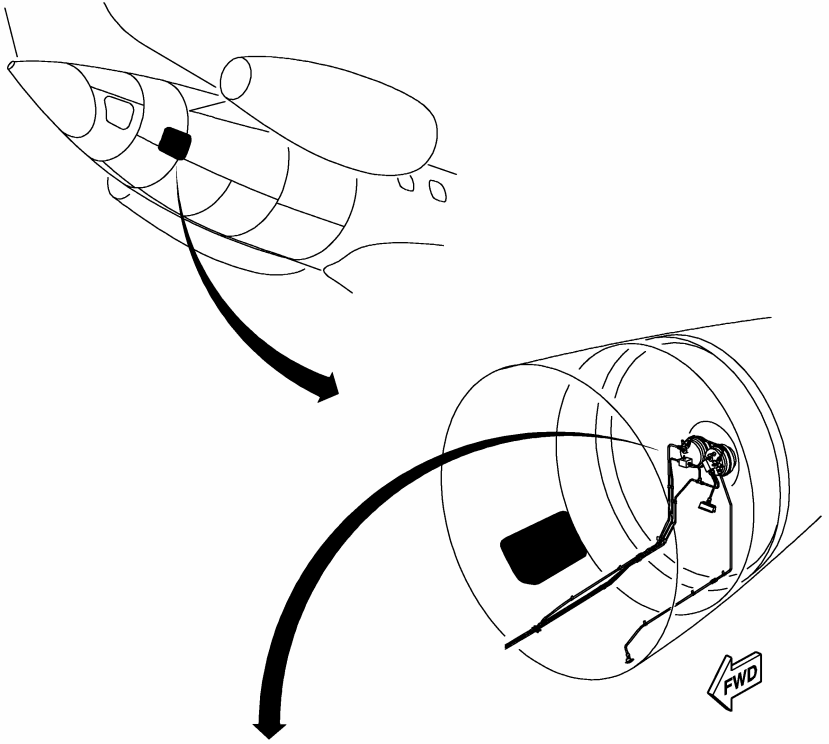

145DDPM090001.MCE

OUTFLOW VALVE SECURED OPEN

DDPM-145/1116

REVISION 9

1-09-21	Page 11	Code 02
---------	---------	---------

21-32-01 CABIN PRESSURE ACQUISITION MODULE

Placard Digital Controller "CABIN ALT WARN INOP", or "CABIN DIFF PRESS IND INOP", or "CABIN ALT IND INOP", or "CABIN RATE OF CHANGE IND INOP".

OPERATIONAL PROCEDURES

Refer to Item 21-31-03 for unpressurized configuration.

Use to convert cabin differential pressure into cabin altitude:

AIRPLANE ALTITUDE (ft)	CABIN ALTITUDE (ft)	DIFFERENTIAL PRESSURE (psi)
10000	300	4.4
11000	500	4.7
12000	700	5.0
13000	900	5.2
14000	1100	5.5
15000	1300	5.7
16000	1500	5.9
17000	1700	6.1
18000	1900	6.3
19000	2200	6.5
20000	2400	6.7
21000	2700	6.8
22000	2900	7.0
23000	3200	7.1
24000	3400	7.2
25000	3800	7.3
26000	4100	7.4
27000	4400	7.5
28000	4700	7.6
29000	5000	7.6
30000	5400	7.7
31000	5700	7.7
32000	6100	7.7
33000	6500	7.7
34000	6800	7.8
35000	7200	7.8
36000	7600	7.8
37000	8000	7.8

MAINTENANCE PROCEDURES

Refer to Item 21-31-03 for outflow valves secured open, if required.

1-09-21	Page 12	Code 02
---------	------------	------------

21-32-02 CABIN PRESSURE CONTROL SYSTEM HIGH ALTITUDE MODE

Placard "CABIN PRESS CTRL SYS HI ALT MODE INOP".

OPERATIONAL PROCEDURES

None.

MAINTENANCE PROCEDURES

None.

21-51-00 AIR CONDITIONING PACK SYSTEMS

Placard affected Air Conditioning Pack Button "INOP".

OPERATIONAL PROCEDURES

- NOTE:** - The EICAS caution message PACK 1 (2) OVLD may be displayed.
- Pack 1 will not close in case of single pack above 24000 ft in icing conditions.

Unpressurized Configuration (airplanes with conventional electromechanical standby instruments):

Refer to Item 21-31-03 for unpressurized configuration. In this condition, ambient temperature, on the ground, must be below ISA + 21°C.

NOTE: The EICAS advisory message BLD 1 (2) VLV CLSD may be displayed.

Operational Check of Pack and Recirculation Fan (airplanes with ISIS):

The recirculation fan operates only when the RECIRC switch is ON and the related pack valve is open. Set the RECIRC switch to ON and check that the airflow through the cockpit general outlets increases.

NOTE: The EICAS advisory message BLD 1 (2) VLV CLSD may be displayed.

MAINTENANCE PROCEDURES

Ram Air Valves Operational Check (airplanes with conventional electromechanical standby instruments):

Perform TASK 21-25-01-700-801-A (AMM) for ram air valves operational check.

DDPM-145/1116



21-60-04 COCKPIT AUTOMATIC AND MANUAL TEMPERATURE CONTROL SYSTEMS

Placard associated Temperature Control Mode Knob "AUTO INOP" or Placard affected Air Conditioning Pack Button "INOP".

OPERATIONAL PROCEDURES

Associated Temperature Control Mode Selector..... MAN

Monitor cabin or cockpit temperature and control it by using the associated Temperature Adjusting Knob.

NOTE: The EICAS caution message PACK 1 (2) OVLD may be displayed.

Operational Check of Pack and Recirculation Fan (airplanes with ISIS):

The recirculation fan operates only when the RECIRC switch is ON and the related pack valve is open. Set the RECIRC switch to ON and check that the airflow through the cockpit general outlets increases.

NOTE: The EICAS advisory message BLD 1 (2) VLV CLSD may be displayed.

MAINTENANCE PROCEDURES

None.

1-09-21	Page 14	Code 02
---------	------------	------------

21-60-05 CABIN AUTOMATIC AND MANUAL TEMPERATURE CONTROL SYSTEMS

Placard associated Temperature Control Mode Knob "MAN INOP" or Placard affected Air Conditioning Pack Button "INOP".

OPERATIONAL PROCEDURES

NOTE: The EICAS caution message PACK 1 (2) OVLD may be displayed.

Operational Check of Pack and Recirculation Fan (airplanes with ISIS):

The recirculation fan operates only when the RECIRC switch is ON and the related pack valve is open. Set the RECIRC switch to ON and check that the airflow through the cockpit general outlets increases.

NOTE: The EICAS advisory message BLD 1 (2) VLV CLSD may be displayed.

MAINTENANCE PROCEDURES

None.



21-60-06 ATTENDANT'S TEMPERATURE CONTROL

Placard Attendant's Temperature Control "INOPERATIVE".

OPERATIONAL PROCEDURES

None.

MAINTENANCE PROCEDURES

None.

21-61-02 COCKPIT AND CABIN TEMPERATURE INDICATION SYSTEMS

Placard Air Conditioning and Pneumatic Control Panel "CABIN TEMP IND INOP" or "CKPT TEMP IND INOP".

OPERATIONAL PROCEDURES

None.

MAINTENANCE PROCEDURES

None.

1-09-21	Page 16	Code 02
---------	------------	------------

ATA CHAPTER 22 AUTOPILOT

22-10-00 AUTOPILOT/FLIGHT DIRECTOR FUNCTIONS

Placard Flight Guidance Controller "AP/FD/YD INOP".

OPERATIONAL PROCEDURES

None.

MAINTENANCE PROCEDURES

None.

22-11-01 FLIGHT GUIDANCE CONTROLLER PANEL

Placard affected Flight Guidance Controller Panel button or knob "INOP".

OPERATIONAL PROCEDURES

Flight Director Buttons Inoperative:

In case of no FD indication on PFD, select any button from flight guidance panel (except FD buttons) and it will be indicated on PFD.

Yaw Damper Engage Button Inoperative:

Verify AP and YD indication on PFD with autopilot engaged.

Operational Altitude Preselect Knob Check:

On ground, with airplane energized, turn the Altitude Preselect Knob (ASEL) selecting altitudes above and below the field elevation, verify that the selected altitude matches the desired altitude and if is displayed on the top right corner of the PFD.

Altitude Preselect Knob (ASEL) Inoperative:

Refer to item 34-31-02 Operational Procedure.

MAINTENANCE PROCEDURES

None.

22-11-08 TOUCH CONTROL STEERING BUTTON (TCS SYNC BUTTONS)

Placard Flight Guidance Controller Panel "LEFT OR RIGHT OR BOTH TCS BUTTON INOP".

OPERATIONAL PROCEDURES

None.

MAINTENANCE PROCEDURES

None.

22-11-09 GO-AROUND BUTTONS

Placard Flight Guidance Controller Panel "LEFT or RIGHT or BOTH GA BUTTON INOP".

OPERATIONAL PROCEDURES

CAT I Operation:

None.

CAT II Operation:

Go-Around Button Check:

For CAT II operation, at least one go-around button must be operative. Before engine start, press the operative Go-Around Button and check that the Takeoff Submode become available on the EADI.

MAINTENANCE PROCEDURES

None.

ATA CHAPTER 23 COMMUNICATIONS

23-00-00 COMMUNICATIONS SYSTEM (VHF, HF, UHF)

Placard associated Control Panel "VHF or HF or UHF INOP".

OPERATIONAL PROCEDURES

Perform TASK 23-15-00-700-801-A (AMM) for operational test of the SATCOM system.

MAINTENANCE PROCEDURES

None.

23-15-00 SATELLITE COMMUNICATION SYSTEM (SATCOM)

Placard SATCOM handset "INOP".

OPERATIONAL PROCEDURES

According to MMEL remarks.

MAINTENANCE PROCEDURES

None.

23-20-01 ACARS SYSTEM

Placard ACARS Panel or Printer "INOP".

OPERATIONAL PROCEDURES

Alternate procedures must be created according to each operator's characteristics in order to establish communications between flight crew and ground station.

MAINTENANCE PROCEDURES

None.



23-21-01 SELECTIVE CALL SYSTEM (SELCAL)

Placard SELCAL Panel "SELCAL INOP".

OPERATIONAL PROCEDURES

Alternate procedures must be created according to each operator's characteristics in order to establish communications between ground station and flight crew.

MAINTENANCE PROCEDURES

None.

23-24-00 CONTROLLER-TO-PILOT DATA LINK (CPDLC)

Placard CDU display "CPDLC INOP".

OPERATIONAL PROCEDURES

Alternate procedures must be created according to each operator's characteristics in order to establish communications between ground station and flight crew.

MAINTENANCE PROCEDURES

None.

23-30-01 PASSENGER ADDRESS SYSTEM

Placard Digital Audio Panels "PAX ADRS INOP".

OPERATIONAL PROCEDURES

Alternate normal and emergency procedures must be created according to each operator characteristics in order to establish communications between flight crew and passengers, when required. A megaphone may be used to transmit relevant information to the passengers.

MAINTENANCE PROCEDURES

None.

1-09-23	Page 2	Code 02
---------	-----------	------------

23-31-01 CREWMEMBER INTERPHONE SYSTEM(S)

Placard ICU Panel "CREWMEMBER INTERPHONE INOP".

OPERATIONAL PROCEDURES

Alternate procedures must be created according to each operator's characteristics in order to establish communications between flight deck and cabin.

MAINTENANCE PROCEDURES

None.

23-31-02 ALERTING SYSTEMS (AUDIO/VISUAL)

Placard CABIN or CAB EMER Buttons on ICU Panel "LIGHT INOP".
Placard CABIN Button on ICU Panel, PILOT light in the attendants handset or secondary attendant call panel "LIGHT INOP".
Placard CABIN Button and ICU Panel or PILOT light in the attendants handset "CHIME INOP".

OPERATIONAL PROCEDURES

Alternate procedures must be created according to each operator characteristics in order to alert the attendant when is required.

MAINTENANCE PROCEDURES

None.

23-31-03 HANDSET SYSTEMS

Placard Attendant's Handset "INOP".

OPERATIONAL PROCEDURES

Alternate procedures must be created according to each operator's characteristics in order to establish communications between attendant and flight deck/passengers.

MAINTENANCE PROCEDURES

None.

23-32-02 PRE – RECORDED PASSENGER ANNOUNCEMENT SYSTEM

Placard Entertainment System Panel "INOP".

OPERATIONAL PROCEDURES

Alternate procedures must be created according to each operator's characteristics in order to instruct the passengers.

MAINTENANCE PROCEDURES

None.

23-33-01 PASSENGER CABIN SPEAKERS

Placard Digital Audio Panels "PAX SPEAKERS INOP".

NOTE: Alternate normal and emergency procedures must be created according to each operator's characteristics in order to establish communications between flight crew and passengers, when required. A megaphone may be used to transmit relevant information to the passengers.

OPERATIONAL PROCEDURES

None.

MAINTENANCE PROCEDURES

None.

23-51-03 PUSH TO TALK (PTT) (BUTTON ON GLARESHIELD PANEL CONTROL WHEEL)

Placard affected PTT Button "INOP".

OPERATIONAL PROCEDURES

None.

MAINTENANCE PROCEDURES

None.

1-09-23	Page 4	Code 02
---------	-----------	------------

23-51-04 FLIGHT DECK SPEAKERS

Placard Digital Audio Panels "FLT DECK SPEAKERS INOP".

OPERATIONAL PROCEDURES

None.

MAINTENANCE PROCEDURES

None.

23-51-05 FLIGHT DECK HEADSETS

Placard affected headset "INOP".

OPERATIONAL PROCEDURES

None.

MAINTENANCE PROCEDURES

None.

23-51-07 FLIGHT DECK HANDHELD MICROPHONES

Placard Pilot's Jack Panels "HAND MIC INOP".

OPERATIONAL PROCEDURES

None.

MAINTENANCE PROCEDURES

None.



23-70-00 FLIGHTDECK DOOR MONITORING SYSTEM

Placard affected monitoring system "INOP".

OPERATIONAL PROCEDURES

According to MMEL remarks.

MAINTENANCE PROCEDURES

None.

23-71-00 COCKPIT VOICE RECORDER SYSTEM

Placard Voice Recorder Panel "INOP".

OPERATIONAL PROCEDURES

None.

MAINTENANCE PROCEDURES

None.

23-73-00 VIDEO SURVEILLANCE SYSTEM (VSS)

Placard as appropriate.

OPERATIONAL PROCEDURES

Alternate procedures are established and used to identify personnel requesting entry in the cockpit.

MAINTENANCE PROCEDURES

Pull and collar CB E8 on the cockpit circuit breakers panel.

23-80-00 RADIO MANAGEMENT UNITS (RMU'S)

Placard associated RMU Bezel "NAV/COM TUN INOP" or "MEM FUNC INOP".

OPERATIONAL PROCEDURES

None.

MAINTENANCE PROCEDURES

None.

1-09-23	Page 6	Code 02
---------	-----------	------------



DISPATCH DEVIATIONS PROCEDURES MANUAL

ATA CHAPTER 23
COMMUNICATIONS

23-81-02 TUNING BACKUP CONTROL HEAD

Placard Tuning Backup Control Head Panel "INOP".

OPERATIONAL PROCEDURES

None.

MAINTENANCE PROCEDURES

None.

DDPM-145/1116

REVISION 9

1-09-23	Page 7	Code 02
---------	-----------	------------

**DISPATCH
DEVIATIONS
PROCEDURES
MANUAL**



INTENTIONALLY BLANK

1-09-23	Page 8	Code 02
---------	-----------	------------

REVISION 9

DDPM-145/1116

ATA CHAPTER 24 ELECTRICAL POWER

24-20-01 GENERATOR CURRENT INDICATIONS

Placard affected Generator Button "CURRENT IND INOP".

OPERATIONAL PROCEDURES

According to the MMEL remarks.

MAINTENANCE PROCEDURES

None.

24-20-02 GENERATOR VOLTAGE INDICATIONS

Placard affected Generator Button "VOLT IND INOP".

OPERATIONAL PROCEDURES

None.

MAINTENANCE PROCEDURES

None.

24-20-03 INVERTER

Placard AC PWR Button "INOP" and placard PFD Bezel "GPWS/TCAS INOP".

- NOTE:** - TCAS may be electric fed by either inverter or DC Bus. Only TCAS powered by the inverter is considered inoperative.
- GPWS/Windshear may be fed by DC bus or AC bus. Only GPWS/Windshear powered by AC bus is considered inoperative.

OPERATIONAL PROCEDURES

None.

MAINTENANCE PROCEDURES

None.



24-31-01 ENGINE DRIVEN GENERATORS

Placard affected Generator Button "INOP".

OPERATIONAL PROCEDURES

According to the MMEL remarks.

MAINTENANCE PROCEDURES

May be flight crewmember accomplished. These procedures are to help maintenance to identify the faulty generator, that carries all loads and avoid dispatch the airplane with the good generator (zero load) inoperative.

The following maintenance procedures should be accomplished only if flight crew reports a continuous contactor switching noise with an unusual generating indication and no associated EICAS message. In this case, the faulty generator is absorbing all the load while operating in parallel with other in good condition. In this condition, the voltage and current indication on MFD Electrical page of the faulty generator indicates that it is carrying all loads, while the voltage and current indication on MFD Electrical page of the good generator indicates zero load. In this failure mode, the unloaded generator remains connected to the DC Bus. Its line contactor cycles and there is no GEN OFF BUS message. In order to identify the faulty generator, proceed as follows:

- BUS TIES Switch OFF
- All GEN Button ON
- Voltage and Current (All Generators - on MFD) CHECK

If there is any generator carrying all the load:

- Affected GEN Button OFF
- BUS TIES Switch ON
- Voltage and Current
(Remaining 3 Generators - on MFD) CHECK

If the 3 remaining generators are operating normally, disconnect the affected generator of the respective DC Bus by releasing its button on the Electric System Panel.

Additionally, pull and safety affected generator GEN 1 (2, 3 or 4) POR and GEN 1 (2, 3 or 4) OUTVOLT circuit breakers:

GENERATOR	CIRCUIT BREAKERS
1	E8 and E9 Left DC Distribution Box
2	E8 and E9 Right DC Distribution Box
3	D8 and D9 Left DC Distribution Box
4	D8 and D9 Right DC Distribution Box

**24-31-02 ENGINE DRIVEN GENERATORS BEARINGS
(ONLY FOR 30086-11 GENERATOR MODEL)**

OPERATIONAL PROCEDURES

None.

MAINTENANCE PROCEDURES

None.



24-34-01 APU STARTER GENERATOR

In case of Generator Function failure, placard APU Starter Generator Button "INOP".

OPERATIONAL PROCEDURES

None.

MAINTENANCE PROCEDURES

None.

24-37-00 DC/DC POWER CONVERSION SYSTEM

Placard "DO NOT USE IN FLIGHT".

OPERATIONAL PROCEDURES

None.

MAINTENANCE PROCEDURES

None.

24-40-00 EXTERNAL POWER SYSTEM

Placard GPU Button "GPU SYS INOP" or "GPU AVAIL LIGHT INOP".

OPERATIONAL PROCEDURES

None.

MAINTENANCE PROCEDURES

None.

1-09-24	Page 4	Code 02
---------	-----------	------------

ATA CHAPTER 25 EQUIPMENT AND FURNISHINGS

25-11-00 EYE LOCATOR

Placard on Windshield Central Frame Top "EYE LOCATOR REMOVED".

OPERATIONAL PROCEDURES

None.

MAINTENANCE PROCEDURES

None.

25-11-01 FLIGHT CREW SEATS

Placard the affected Seat Control "INOP".

OPERATIONAL PROCEDURES

In case of vertical power seat adjustment failure, use the manual system to adjust the seat.

MAINTENANCE PROCEDURES

May be flight crewmember accomplished. In case of vertical power seat adjustment, pull and safety the associated SEAT ADJUST circuit breaker (E5 or E28).

NOTE: Some airplanes may present a different circuit breaker positioning configuration. Specific configuration may be found in the Aircraft Maintenance Manual (AMM).



25-11-02 PRIMARY OBSERVER SEAT (INCLUDING ASSOCIATED EQUIPMENT)

Placard Observer's Seat "OBSERVER'S SEAT INOP - DO NOT OCCUPY". If required, placard one Passenger Seat "RESERVED". If only the Audio Panel is inoperative, placard it "INOP".

NOTE: If the Oxygen System Pressure is insufficient for three cockpit occupants, the observer seat must be considered inoperative.

OPERATIONAL PROCEDURES

None.

MAINTENANCE PROCEDURES

None.

25-11-04 FLIGHT ATTENDANT SEAT ASSEMBLY

Placard Attendant's Seat "INOP - DO NOT OCCUPY". Placard assigned Passenger Seat "FOR FLIGHT ATTENDANT ONLY".

OPERATIONAL PROCEDURES

Flight Attendant will occupy the passenger seat closest to her duty station. Upon completion of before takeoff cabin announcements and cabin inspection, Flight Attendant will notify the captain that it is ready for departure. Captain will allow the Flight Attendant to be seated before takeoff roll. All other Flight Attendant procedures remain the same.

MAINTENANCE PROCEDURES

May be flight crewmember accomplished. The seat may be secured in the stowed position by using seat belt/shoulder harness or secured with baggage tape or equivalent.

1-09-25	Page 2	Code 02
---------	-----------	------------

25-12-01 SUNVISORS

If not missed, placard the affected sunvisor "INOP".

OPERATIONAL PROCEDURES

None.

MAINTENANCE PROCEDURES

None.

25-12-02 COCKPIT CONVENIENCE ITEM(S)

OPERATIONAL PROCEDURES

None.

MAINTENANCE PROCEDURES

None.

25-12-03 LIGHTED/MECHANICAL CHECKLIST

Placard the affected Mechanical Checklist Panel "INOP".

OPERATIONAL PROCEDURES

None.

MAINTENANCE PROCEDURES

None.

25-12-04 CHART HOLDERS

If not missing, placard the affected Chart Holder "INOP".

OPERATIONAL PROCEDURES

None.

MAINTENANCE PROCEDURES

None.



25-21-05 PASSENGER SEAT(S)

Placard the associated Seat "DO NOT OCCUPY" or "DO NOT STOW BAGGAGE UNDER THIS SEAT".

OPERATIONAL PROCEDURES

As required to meet MMEL remarks.

MAINTENANCE PROCEDURES

May be flight crewmember accomplished. As required to meet MMEL remarks.

25-22-00 OVERHEAD STORAGE BIN(S) / CABIN AND GALLEY STORAGE COMPARTMENT/ CLOSETS

Placard Overhead Bin "INOPERATIVE DO NOT USE".

OPERATIONAL PROCEDURES

Notify Flight Attendant that no items are to be stowed in the affected compartment.

MAINTENANCE PROCEDURES

Overhead Bin Removal:

Perform TASK 25-22-03-000-801-A (AMM) for overhead bin removal.

Overhead Bin secured closed or open:

May be flight crewmember accomplished. As required to secure open or closed. The door may be secured closed using suitable self-adhesive tape applied vertically over the bin latch with an overlap of at least 4" above and below from the latch.

25-27-02 LAVATORY BULKHEAD PEEPHOLE

OPERATIONAL PROCEDURES

None.

MAINTENANCE PROCEDURES

Perform TASK 25-27-02-300-801-A (AMM) to repair the forward baggage compartment partition.

25-27-09 FORWARD ATTENDANT CONTROL PANEL COVER

OPERATIONAL PROCEDURES

None.

MAINTENANCE PROCEDURES

None.

25-30-01 GALLEY WASTE RECEPTACLES ACCESS DOORS/COVERS

Placard Waste Door Assembly "INOP".

OPERATIONAL PROCEDURES

According to MMEL remarks.

MAINTENANCE PROCEDURES

May be flight crewmember accomplished. As required to secure the door in the closed position.

25-40-00 EXTERIOR LAVATORY DOOR ASHTRAYS

Register in the appropriate logbook for maintenance actions.

OPERATIONAL PROCEDURES

None.

MAINTENANCE PROCEDURES

None.

DDPM-145/1116

REVISION 10

1-09-25	Page 5	Code 02
---------	-----------	------------

25-50-01 CARGO RESTRAINT SYSTEMS

Register in the appropriate logbook for reinstallation actions.

OPERATIONAL PROCEDURES

None.

MAINTENANCE PROCEDURES

None.

25-60-02 NON-ESSENTIAL EQUIPMENT AND FURNISHINGS (NEF)

Placard affected Item "INOP".

OPERATIONAL PROCEDURES

As defined by each operator.

MAINTENANCE PROCEDURES

As defined by each operator.

25-60-04 LIFE RAFT

Placard as appropriate.

OPERATIONAL PROCEDURES

According to MMEL remarks.

MAINTENANCE PROCEDURES

May be flight crewmember accomplished. Remove the installed life raft from its location. Place the inoperative life raft out of sight so it can not be mistaken for a functional unit.

1-09-25	Page 6	Code 02
---------	-----------	------------

25-60-05 FLIGHT DECK/ATTENDANT FLASHLIGHT HOLDER ASSEMBLIES

Placard affected Flight Deck/Attendant Flashlight Holder Assembly "INOP" or "REMOVED".

OPERATIONAL PROCEDURES

None.

MAINTENANCE PROCEDURES

None.

25-60-06 MEGAPHONES

Placard associated Megaphone Assembly "MEGAPHONE REMOVED".

OPERATIONAL PROCEDURES

None.

MAINTENANCE PROCEDURES

None.

25-60-07 PYROTECHNIC SIGNAL DEVICES

Placard Pyrotechnic Signal Device or Assembly "INOP" or "REMOVED".

OPERATIONAL PROCEDURES

None.

MAINTENANCE PROCEDURES

None.

25-60-09 EMERGENCY MEDICAL EQUIPMENT

Register in the appropriate document for necessary actions.

OPERATIONAL PROCEDURES

As required to meet the regulation requirements.

MAINTENANCE PROCEDURES

None.

DDPM-145/1116

REVISION 12

1-09-25	Page 7	Code 02
---------	-----------	------------

25-60-10 "FASTEN SEAT BELTS WHILE SEATED" SIGNS OR PLACARD

OPERATIONAL PROCEDURES

None.

MAINTENANCE PROCEDURES

None.

25-61-01 EMERGENCY LOCATOR TRANSMITTER (ELT)

Placard ELT Panel "ELT INOP".

OPERATIONAL PROCEDURES

None.

MAINTENANCE PROCEDURES

Perform TASK 25-61-01-040-801-A (AMM) for system deactivation.

25-64-02 FLOTATION EQUIPMENT (CREW AND PASSENGER)

OPERATIONAL PROCEDURES

None.

MAINTENANCE PROCEDURES

None.

1-09-25	Page 8	Code 02
---------	-----------	------------

ATA CHAPTER 26 FIRE PROTECTION

26-12-00 APU FIRE DETECTION SYSTEM

Placard APU Control Panel "APU FIRE DET INOP - DO NOT USE APU".

OPERATIONAL PROCEDURES

None.

MAINTENANCE PROCEDURES

None.

26-14-00 LAVATORY SMOKE DETECTION SYSTEM

Placard Lavatory Door "INOPERATIVE - DO NOT ENTER", if applicable.

OPERATIONAL PROCEDURES

According to the MMEL remarks.

MAINTENANCE PROCEDURES

Lavatory Fire Extinguisher Bottle Pressure check:

May be flight crewmember accomplished. Perform TASK 26-25-01-200-801-A (AMM) to inspect and check the Lavatory Waste Auto-Fire Extinguisher Bottle.

**26-15-00 BAGGAGE COMPARTMENT SMOKE
DETECTION SYSTEM**

Placard Fire Detection/Extinguishing Panel "BAGG SMOKE DET INOP".

OPERATIONAL PROCEDURES

According to the MMEL remarks.

MAINTENANCE PROCEDURES

None.

**26-15-10 BAGGAGE COMPARTMENT SMOKE
DETECTOR PROTECTIVE BAR**

Placard as appropriate.

OPERATIONAL PROCEDURES

None.

MAINTENANCE PROCEDURES

None.

**26-21-02 E1 (2) EXBTBLA (B) INOP CAUTION
MESSAGES**

Placard on associated Engine Fire Detection/Extinguishing Panel "E1 (or 2) EXBTBLA (or B) INOP MESSAGE NOT AVAIL".

OPERATIONAL PROCEDURES

None.

MAINTENANCE PROCEDURES

Engine Fire Extinguishing System Functional Check:

Perform TASK 26-21-00-700-801-A (AMM) for engine fire extinguishing system functional check.

For airplanes Pre-Mod. SB 145-26-0007, if the EICAS message are triggered only when flying above FL 240, going off below such altitude, it may be a spurious message associated with an improper operation of the fire extinguishing bottle pressure switch. In this case, replace the task above by the following check:

- Perform once a continuity and isolation check on the wiring from the GS0827DC to the pin # A-14/ connector J1018 (DAU-2) and from GS0826DC to the pin # A-14/ connector J1020 (DAU-2). Wiring Manual (WM) references 26-21-50 and 26-21-51. Check no fault found.

Engine Fire Extinguishing Bottles Pressure Check:

The respective manometers of the affected extinguisher bottles must be checked before the first flight of each calendar day. For dispatch purpose the fire extinguisher bottles minimum pressure must be higher then values presented on the table below.

Temperature		Gauge Pressure Indication Minimum Pressure (psi)
°C	°F	
-54 to -40	-65 to -40	300
-29	-20	350
-18	0	400
-7	20	450
4	40	500
16	60	550
21 to 27	70 to 80	600
38	100	700
49	120	800
60	140	900

26-22-00 APU FIRE EXTINGUISHING SYSTEM

Placard APU Panel "APU FIRE EXTING INOP - DO NOT USE APU".

OPERATIONAL PROCEDURES

None.

MAINTENANCE PROCEDURES

None.

26-22-01 APU EXTBTL INOP CAUTION MESSAGE

Placard APU Fire Detection/Extinguishing Panel "APU EXTBTL INOP NOT AVAIL".

OPERATIONAL PROCEDURES

None.

MAINTENANCE PROCEDURES

Perform TASK 26-22-00-700-801-A or 26-22-00-700-802-A (AMM) for testing the APU Fire Extinguishing System.

26-23-00 BAGGAGE COMPARTMENT FIRE EXTINGUISHER SYSTEM

Placard Fire Detection/Extinguishing Panel "BAGG EXTG INOP".

OPERATIONAL PROCEDURES

None.

MAINTENANCE PROCEDURES

None.

26-23-01 PORTABLE FIRE EXTINGUISHER

Placard the associated Portable Fire Extinguisher "INOP" or "REMOVED", near its normal storage place.

OPERATIONAL PROCEDURES

None.

MAINTENANCE PROCEDURES

None.

26-25-00 LAVATORY FIRE EXTINGUISHER SYSTEMS

Placard Lavatory Door "INOPERATIVE - DO NOT ENTER", if applicable.

OPERATIONAL PROCEDURES

Lavatory Smoke Detector System test:

TEST Button PRESS

Check that the following test indications are activated:

- SMOKE red alarm light on the lavatory smoke detector panel.
- Horn activated on lavatory smoke detector panel.
- LAV SMOKE warning message on EICAS.
- Normal operation green light extinguished.

HORN RESET Button..... PRESS

MAINTENANCE PROCEDURES

May be flight crewmember accomplished. Check that lavatory waste receptacle is empty.



26-25-01 GALLEY FIRE EXTINGUISHER SYSTEM

Placard galley door "GALLEY EXTG INOP".

OPERATIONAL PROCEDURES

None.

MAINTENANCE PROCEDURES

None.

1-09-26	Page 6	Code 02
---------	-----------	------------

REVISION 9

ATA CHAPTER 27 FLIGHT CONTROLS

27-10-01 AILERON DAMPERS

Placard Aileron Damper "INOP".

OPERATIONAL PROCEDURES

None.

MAINTENANCE PROCEDURES

Aileron Damper Deactivation:

Perform TASK 27-12-03-040-801-A (AMM) for Aileron Damper Deactivation.

Aileron Damper Visual Inspection:

Perform the visual inspection of the affected PCA rod ends and fittings according to the lasted approved revision of the AD 99-05-04.

27-14-00 ROLL TRIM POSITION INDICATION

Placard Roll Trim Switch "POSITION INDICATION INOP".

OPERATIONAL PROCEDURES

Aileron in Neutral Position check:

- Airplane.....DEENERGIZED
- Control WheelsNEUTRAL POSITION
- AileronsNEUTRAL POSITION
- Airplane.....ENERGIZE
- Roll Trim Switch.....RELEASED
- Electric Hydraulic Pumps.....ON
- Control WheelsNEUTRAL POSITION
- AileronsNEUTRAL POSITION

MAINTENANCE PROCEDURES

None.



27-15-00 AILERON DISCONNECTION LIGHT

Placard AIL DISC Caution Light "INOP".

OPERATIONAL PROCEDURES

Aileron Mechanical Interconnection check:

Left Control Wheel	HOLD FIRMLY IN NEUTRAL POSITION
Right Control Wheel	TRY TO TURN LEFT AND RIGHT

If relative movement between both control wheels is not observed, then the aileron mechanical interconnection is connected.

MAINTENANCE PROCEDURES

None.

27-21-03 PEDAL ADJUSTMENT MECHANISMS

Placard associated Pedal Adjustment Switch "INOP".

OPERATIONAL PROCEDURES

With seats adjusted, check pedals for full travel. If the extreme pedal positions can not be reached, readjust the seat or report to the maintenance personnel for pedal adjustment.

MAINTENANCE PROCEDURES

- Make sure that the aircraft is safe for maintenance.
 - Do not do other tasks on the rudder system.
 - Make sure the CB0383 (E5) is opened.
 - Remove cockpit underfloor access hatch 123BL (AMM 06-41-01/101).
 - In the interconnection pedal assembly, locate the pedal regulator guide. Inside the guide there will be a pedal regulator spindle. Using an 1/4" wrench, turn slowly clockwise or counterclockwise to move the rudder pedal assembly forward or rearward to suit the pilot requirements.
- NOTE:** Make sure that the 1/4" wrench fits in the protruded end of the spindle to avoid any damage to the component.
- Once finished the adjustment, install cockpit underfloor access hatch 123BL (AMM 06-41-01/101).
 - Close CB0383 (E5) and return the airplane back to service.

NOTE: Some airplanes may present a different circuit breaker positioning configuration. Specific configuration may be found in the Aircraft Maintenance Manual (AMM).

1-09-27	Page 2	Code 02
---------	-----------	------------

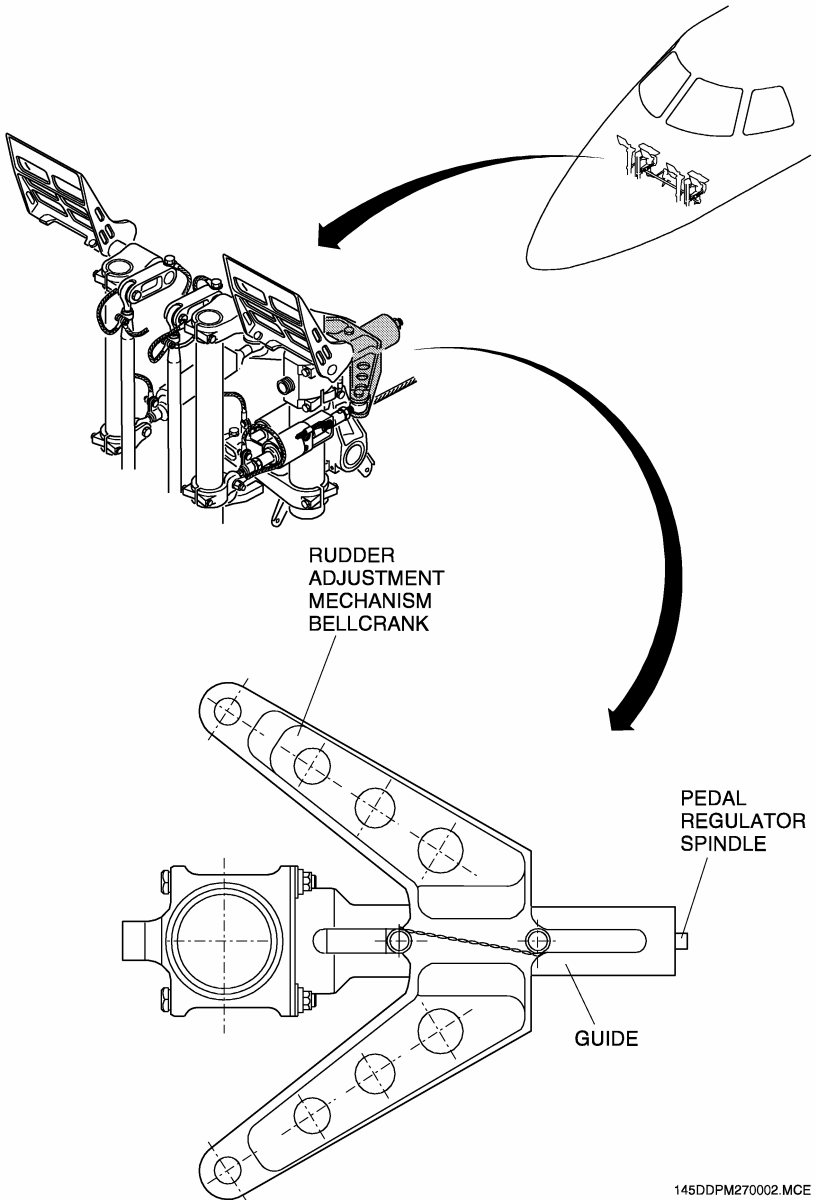

145DDPM270002.MCE

RUDDER ADJUSTMENT MECHANISM BELLCRANK

DDPM-145/1116

REVISION 9

1-09-27	Page 3	Code 02
---------	-----------	------------



27-24-01 YAW TRIM POSITION INDICATIONS

Placard YAW TRIM Knob "INOP".

OPERATIONAL PROCEDURES

Rudder in Neutral Position check:

- Airplane DEENERGIZED
- Rudder Pedals NEUTRAL POSITION
- Rudder NEUTRAL POSITION
- Airplane ENERGIZE
- Yaw Trim Knob RELEASED
- Electric Hydraulic Pumps ON
- Rudder Pedals NEUTRAL POSITION
- Rudder NEUTRAL POSITION

MAINTENANCE PROCEDURES

None.

27-35-00 ELEVATOR DISCONNECTION LIGHT

Placard ELEV DISC Light "INOP".

OPERATIONAL PROCEDURES

Elevator Mechanical Interconnection check:

- Left Control Column HOLD FIRMLY IN
NEUTRAL
- Right Control Column..... TRY TO MOVE
FORWARD AND
BACKWARD

If relative movement between both control columns is not observed, then the elevator mechanical interconnection is connected.

MAINTENANCE PROCEDURES

None.

27-36-01 SPS/ICE SPEEDS ADVISORY MESSAGE

Placard SPS/ICE SPEEDS Message "INOP".

OPERATIONAL PROCEDURES

None.

MAINTENANCE PROCEDURES

None.

27-36-03 STICK SHAKERS

Placard Stall Protection System Panel "SHAKER 1 (or 2) INOP".

OPERATIONAL PROCEDURES

None.

MAINTENANCE PROCEDURES

None.

27-40-00 MAIN PITCH TRIM SWITCHES

Placard the non-flying pilot side Control Wheel "PITCH TRIM SWITCH INOP".

OPERATIONAL PROCEDURES

According to the MMEL remarks.

MAINTENANCE PROCEDURES

According to the MMEL remarks.

27-40-01 PITCH TRIM POSITION INDICATION

Placard near Pitch Trim Cut-out Buttons "POSITION IND INOP".

OPERATIONAL PROCEDURES

Check that stabilizer is correctly set according to CG position by looking at pitch trim marks on vertical stabilizer.

NOTE: - The thick marks represent, respectively, 4° nose down (top of the scale), neutral, and 10° nose up (bottom of the scale) and each intermediate marks represent a 2° variation (See Figure).

- The airplane can be dispatched in case of: no EICAS indication, pitch trim system operating normally, stabilizer correctly set according to CG position by looking at pitch trim marks on vertical stabilizer, and aural warning TAKEOFF TRIM sounds.
- When thrust levers are moved beyond 60°, TAKEOFF TRIM will sound again. Flight crew must confirm that the aural warning is originated from pitch trim position indication inoperative condition.

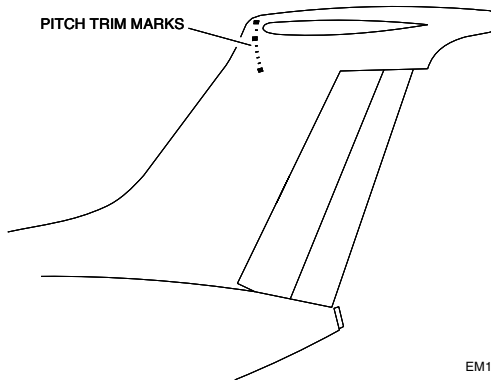

EM145AOM000024A.DGN

PITCH TRIM MARKS

MAINTENANCE PROCEDURES

None.

1-09-27	Page 6	Code 02
---------	-----------	------------

27-53-00 FLAP CHANNELS

Placard near Flap Selector Lever "CHANNEL 1 (or 2) INOP".

OPERATIONAL PROCEDURES

According to the MMEL remarks.

MAINTENANCE PROCEDURES

Perform TASK 27-53-00-040-801-A (AMM) for flap channel deactivation.

NOTE: In order to dispatch with this item inoperative level-off height must be higher than obstacle height.

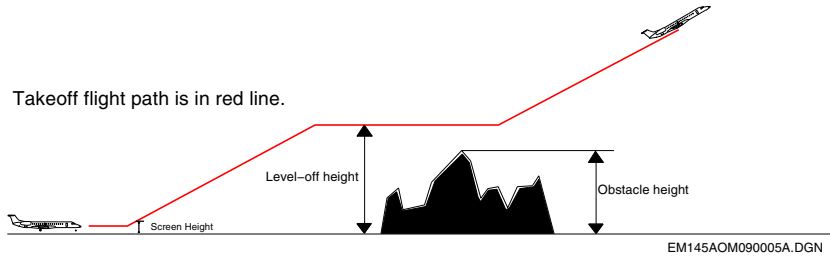



**27-70-00 ELECTRO-MECHANICAL GUST LOCK
SYSTEM**

For airplanes equipped with Electromechanical Gust Lock System:

Placard Gust Lock Lever "INOP" and/or placard affected Gust Lock Amber Light "LIGHT INOP".

OPERATIONAL PROCEDURES

Carefully check elevators are free to move from full forward to full rearward positions. Obtain confirmation from maintenance personnel to check surface full travel.

MAINTENANCE PROCEDURES

1-09-27	Page 8	Code 02
---------	-----------	------------

For airplanes equipped with Electromechanical Gust Lock System:

- Pull the Air/Ground D circuit breaker (A29) and attach a DO-NOT-CLOSE tag to it.
- Move the gust lock lever to unlocked position (full forward).
 - If the lever does not move:
 - Perform TASK 27-71-06-900-801-A (AMM) to manually unlock the electromechanical Gust Lock.
 - If the solenoid rod cannot be moved, perform TASK 27-71-06-000-801-A (AMM) to remove the Gust Lock solenoid.
 - After moving the Gust Lock lever to unlocked position, perform TASK 27-71-06-400-801-A (AMM) to install the Gust Lock solenoid.
- Move the control column backward and forward full stroke.
 - If the control column cannot be moved:
 - Perform TASK 27-71-00-200-801-A (AMM) to do a detailed visual inspection on the electromechanical Gust Lock mechanism. Check for broken, locked or jammed parts.
 - Perform TASK 27-71-01-000-801-A (AMM) to remove the electromechanical Gust Lock actuator located at the tail torque box.
 - Perform TASK 27-71-07-400-801-A (AMM) to install the Gust Lock actuator locking device to keep the locking pins in the unlocked position.
- With the gust lock in the unlocked position, move the control columns forward (nose down) and try to move the gust lock lever to locked position.

NOTE: The gust lock lever can not be moved from unlocked position to locked position.

- If the lever moves to the locked position perform SUB TASK 27-71-00-710-002-A00 (AMM) to assure the Electromechanical Gust Lock Solenoid alignment.
- Pull and collar the Gust Lock circuit breaker (F24) to prevent an inadvertent actuation of the gust lock in flight.
- The GUST LOCK Amber Lights will illuminate and must be masked.
- Push back in the Air/Ground D circuit breaker (A29) and remove the DO-NOT-CLOSE tag from it.

**DISPATCH
DEVIATIONS
PROCEDURES
MANUAL**



- NOTE:** – To avoid damage to the flight control system when the gust lock is disengaged, the airplane must be parked in areas not subjected to gust, such as inside a hangar.
- In case of airplane parked in an open area, install the rig pin in the elevator rear sector (see figure) or secure the elevator by other alternate means approved by local authorities.
 - Perform TASK 05-50-26-200-802-A before the reactivation and/or takeoff if the airplane is blown with any wind velocity values on ground with Gust Lock system inoperative and with the elevator rig pin not installed.
 - Perform TASK 05-50-26-200-802-A if the airplane was exposed to wind velocities higher than 50 kt.
 - Remove rig pin before flight.
 - Monitor control column during taxi, in case of any control column unusual movement (full backward or full forward control), the airplane shall return to gate for further maintenance inspection.

1-09-27	Page 10	Code 02
---------	------------	------------

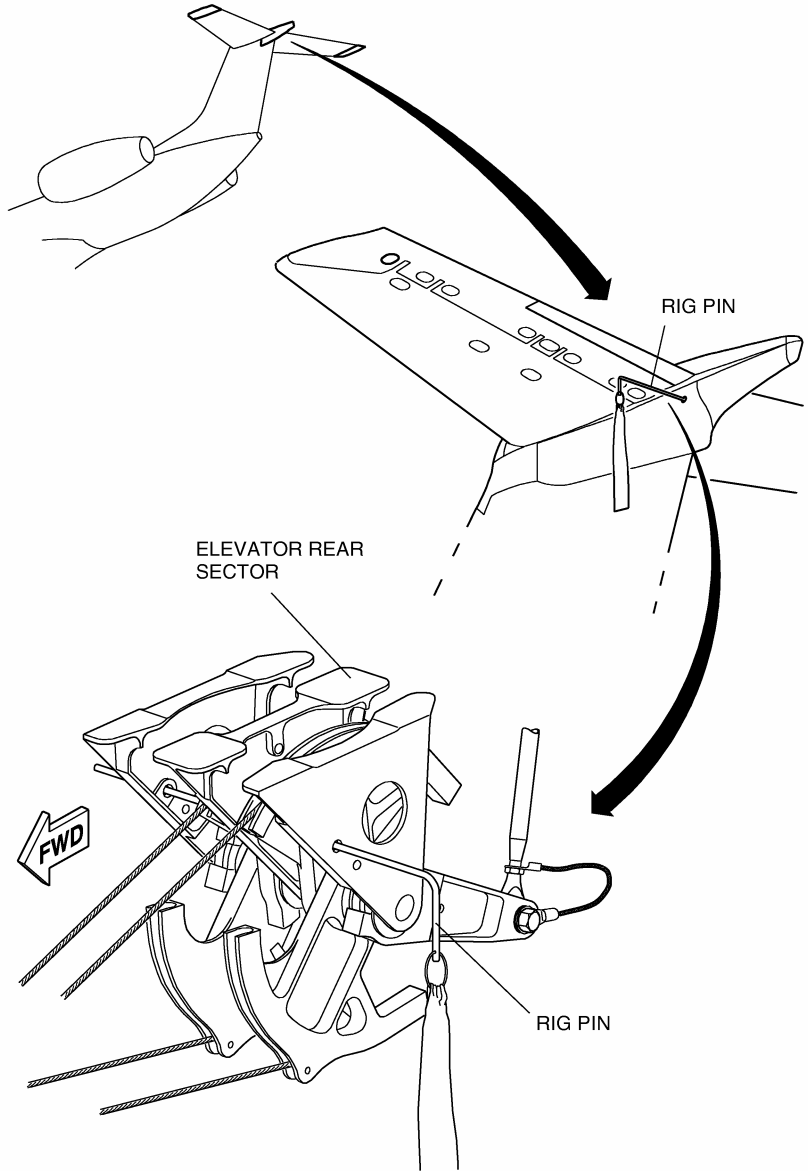

EM145DDPM270003A.DGN

RIG PIN (GSE 058) (ELEVATOR REAR SECTOR)

DDPM-145/1116

REVISION 9

1-09-27	Page 11	Code 02
---------	------------	------------

**DISPATCH
DEVIATIONS
PROCEDURES
MANUAL**



INTENTIONALLY BLANK

1-09-27	Page 12	Code 02
---------	------------	------------

REVISION 9

DDPM-145/1116

ATA CHAPTER 28 FUEL

28-11-02 SUMP DRAIN VALVES

Placard affected Drain Valve Panel "INOP".

OPERATIONAL PROCEDURES

None.

MAINTENANCE PROCEDURES

Check visually the affected valve for no evidence of leakage and no water contamination in the other associated tank. Perform TASK 12-11-03-600-801-A (AMM).

28-11-05 FUELING RECEPTACLE CAP

Placard near Refueling Receptacle "CAP REMOVED".

OPERATIONAL PROCEDURES

None.

MAINTENANCE PROCEDURES

May be flight crewmember accomplished. Before refueling check the receptacle. Make sure there is no contamination. After refueling makes sure there is no evidence of leakage.



28-21-01 WING TANK ELECTRIC FUEL BOOSTER PUMPS

Placard affected Fuel Pump Selector Knob "PUMP A or B or C INOP".

OPERATIONAL PROCEDURES

ELEC EMERG ABNORMAL Message check:

If GPU is available:

- GPU ON
- ESSENTIAL POWER Button PRESS
- ELEC EMERG ABNORMAL Message CHECK ON
- ESSENTIAL POWER Button RELEASE
- ELEC EMERG ABNORMAL Message CHECK OFF

If GPU is not available:

- APU or ENGINE (only one) START
- APU or ENGINE Generator ON
- ESSENTIAL POWER Button PRESS
- ELEC EMERG ABNORMAL Message CHECK ON
- ESSENTIAL POWER Button RELEASE
- ELEC EMERG ABNORMAL Message CHECK OFF

If any electric fuel booster pump is inoperative, the unusable fuel quantity in the associated wing raises as presented in the table below. Therefore, additional fuel should be considered for flight planning purposes.

AIRPLANE MODEL	EMB-135/145 STD/EU/ER/EP/MK/MP	EMB-135/145 LR/LU
Unusable fuel quantity	Up to 149 liters (267 lb)	Up to 203 liters (364 lb)

MAINTENANCE PROCEDURES

May be flight crewmember accomplished.

Electric Fuel Booster Pump Deactivation procedure:

In the DC distribution boxes, open and safe the affected Electric Fuel Booster Pump power circuit breakers:

DISTRIBUTION BOX	PUMP	CIRCUIT BREAKER
LEFT SIDE	1A	A3
	1C	C4
	2B	A4
RIGHT SIDE	1B	A2
	2A	A3
	2C	C4

NOTE: - Some airplanes may present a different circuit breaker positioning configuration. Specific configurations may be found in the Aircraft Maintenance Manual (AMM).

- Pulling the circuit breaker on the distribution box deactivates the pump but may not change the MFD indications (e.g. a deactivated pump still show indications if it is selected). Ensure the selected pump on the overhead panel is not the deactivated pump.



28-21-02 WING TANK ELECTRIC FUEL BOOSTER PUMP OPERATING INDICATIONS

Placard affected Fuel Pump Selector Knob "PUMP A (or B or C) IND INOP".

OPERATIONAL PROCEDURES

None.

MAINTENANCE PROCEDURES

May be flight crewmember accomplished.

Electric Fuel Booster Pump normal operation check:

- Airplane ENERGIZE
- Wing Tanks NOT EMPTY
- Associated Engine START
- MFD Fuel Page SET
- Affected Pump SELECT
- Perform the following check:
 - No MFD pump operation indication.
 - No FUEL LO PRESS displayed on the EICAS caution message.
 - No CAUTION light or aural caution alarm.
- Affected Pump Circuit Breaker PULL
- Perform the following check:
 - Associated caution message displayed on the EICAS.
 - Master Caution light blinking.
 - Aural Warning sounding.
 - MFD indication changing to another pump.
- Affected Pump Circuit Breaker CLOSE
- Check the airplane returning to the original condition.

1-09-28	Page 4	Code 02
---------	-----------	------------

REVISION 10

28-22-01 APU FUEL SHUTOFF VALVE

Placard APU Panel "APU FUEL SHUTOFF VALVE INOP - DO NOT USE APU".

OPERATIONAL PROCEDURES

According to the MMEL remarks.

MAINTENANCE PROCEDURES

Perform TASK 28-22-01-040-801-A (AMM) for APU Fuel Shutoff Valve secured closed.



28-23-00 PRESSURE DEFUELING / REFUELING SYSTEM

Placard Refueling Panel "PRESSURE DEFUELING/REFUELING INOP".

OPERATIONAL PROCEDURES

Operational procedure associated with overfilling condition

Overfilling Condition:

An overfilling condition exists if during the pressure refueling operation there are:

- Fuel leakage through the tank ventilation point, or
- Illumination of the STOP RFL red lights on the refueling panel associated with the wing fuel tank quantity above the values presented in table 1.

NOTE: The STOP RFL lights are applicable only to airplanes equipped with High Level Exceeding Indication System.

Wing Tank Fuel Consumption Procedure:

The following procedure should be performed on ground if the corresponding maintenance defueling procedure is not practical or possible to be done.

Overfilling in One Tank: With the crossfeed selector knob in **LOW1** position (right wing tank overfilling) or in the **LOW2** position (left wing tank overfilling) run both engines in IDLE:

- During 15 minutes, or
- Until the fuel quantity indicated on EICAS/MFD is at or below the values presented in table 1.

Overfilling in Both Tanks: With the crossfeed selector knob in **OFF** position, run both engines in IDLE:

- During 30 minutes, or
- Until the fuel quantity indicated on EICAS/MFD is at or below the values presented in table 1.

Check the fuel balancing between the tanks.

1-09-28	Page 6	Code 02
---------	-----------	------------

MAINTENANCE PROCEDURES

Maintenance procedures not associated with overfilling condition

Wing Tank Gravity Refueling Procedure:

Perform TASK 12-11-02-600-801-A (AMM) for Wing Tank Gravity Refueling.

Wing Tank Gravity Defueling Procedure:

Perform TASK 12-11-02-600-802-A (AMM) for Wing Tank Gravity Defueling.

Maintenance procedures associated with overfilling condition

Overfilling Condition:

An overfilling condition exists if during the pressure refueling operation there are:

- Fuel leakage through the tank ventilation point, or
- Illumination of the STOP RFL red lights on the refueling panel associated with the wing fuel tank quantity above the values presented in table 1.

NOTE: The STOP RFL lights are applicable only to airplanes equipped with High Level Exceeding Indication System.

Wing Tank Defueling Procedure if overfilling condition exists:

Perform TASK 12-11-02-600-802-A (AMM) for Gravity Defueling to remove excess fuel from the wing tanks until the fuel quantity is at or below the values presented in table 1.

Check the fuel balancing between the tanks.

**DISPATCH
DEVIATIONS
PROCEDURES
MANUAL**



**TABLE 1 - WING TANK FUEL QUANTITY LIMIT
(NOT APPLICABLE TO GRAVITY REFUELING OPERATION)**

COCKPIT/REFUELING PANEL INDICATION				
FUEL TEMP	FUEL TANK QUANTITY (kg)		FUEL TANK QUANTITY (lb)	
	(°C)	WING (STD, ER, EP, MP)	WING (LR)	WING (STD, ER, EP, MP)
-40	2030	2530	4480	5570
-35	2030	2520	4460	5550
-30	2020	2510	4440	5520
-25	2010	2490	4420	5500
-20	2000	2480	4400	5480
-15	1990	2470	4380	5450
-10	1980	2460	4360	5430
-5	1970	2450	4340	5400
0	1960	2440	4320	5380
5	1950	2430	4300	5350
10	1940	2420	4280	5330
15	1930	2400	4260	5300
20	1930	2390	4240	5280
25	1920	2380	4220	5250
30	1910	2370	4200	5230
35	1900	2360	4180	5200
40	1890	2350	4160	5180
45	1880	2340	4140	5150
50	1870	2330	4120	5130
52	1870	2320	4120	5120

Check fuel tank temperature on MFD Fuel Page before using the table.

NOTE: Refueling Completion by gravity is allowed if required.

28-23-07 DEFUELING SHUTOFF VALVE

Placard Refueling Panel "DEFUELING SHUTOFF VALVE INOP".

OPERATIONAL PROCEDURES

None.

MAINTENANCE PROCEDURES

Perform TASK 28-23-07-040-801-A (AMM) for Defueling Shutoff Valve secured closed.

NOTE: The EICAS caution message DEFUEL NOT CLOSED may be displayed.

28-23-08 FUEL QUANTITY INDICATOR (REFUELING PANEL)

Placard Refueling Panel "QUANTITY INDICATOR INOP".

OPERATIONAL PROCEDURES

Refer to AOM EMB-145 - Volume I - Section 1-12-25 for gravity refueling.

Monitor fuel quantity indication on MFD and EICAS or with the direct measuring sticks.

MAINTENANCE PROCEDURES

Perform TASK 12-11-02-600-801-A (AMM) for Fuel Tank Gravity refueling.



28-40-00 WING TANK FUEL QUANTITY INDICATIONS (EICAS AND MFD)

Placard MFD or PFD Bezel "FUEL QTY IND INOP".

OPERATIONAL PROCEDURES

If the Fuel Quantity Gauging and Indication System of one wing tank is inoperative, the associated indication will present unreliable information on the EICAS display. On the MFD Fuel Page, both the associated tank indication and the TOTAL fuel quantity will present unreliable information. The EICAS caution message FUEL IMBALANCE may be also presented.

Wing tanks fuel quantity can be measured on ground, through the Direct Measuring Stick System, described on the AOM EMB-145 - Description System - Volume II - Section 2-08-15.

In flight, the aircraft Remaining Fuel Quantity can be determined through the information from the: Flight Card Required/Filled Fuel, FMS fuel data, Fuel Used (FU) of the MFD Fuel Page and the Fuel Flow (FF) of the EICAS/RMU/EFIS.

When one wing tank fuel quantity indication is inoperative, both the Fuel Flow (FF) and the Fuel Used (FU) shall be monitored throughout the whole flight.

NOTE: In case of fuel tank level too high to be measured by the measuring sticks, it may be necessary to have the airplane topped off by gravity refueling.

MAINTENANCE PROCEDURES

None.

1-09-28	Page 10	Code 02
---------	------------	------------

28-42-01 DIRECT QUANTITY MEASURING STICKS

Placard Refueling Panel "DIRECT QTY MEASURING STICKS INOP".

OPERATIONAL PROCEDURES

Check the remaining sources of fuel quantity information such as fuel quantity indications on EICAS and MFD Fuel Page, fuel quantity indicator in refueling panel and fuel loaded.

MAINTENANCE PROCEDURES

None.

28-43-00 FUEL TANK TEMPERATURE INDICATION SYSTEM

Placard MFD Bezel "FUEL TANK TEMP IND INOP".

OPERATIONAL PROCEDURES

None.

MAINTENANCE PROCEDURES

None.

28-44-00 FUEL 1 (OR 2) LO LEVEL MESSAGE

Placard EICAS Bezel "FUEL 1 (or 2) LO LEVEL MESSAGE INOP".

OPERATIONAL PROCEDURES

None.

MAINTENANCE PROCEDURES

None.



28-45-01 E1 (OR 2) FUEL LO PRESS MESSAGE

Placard EICAS Bezel "FUEL 1 (or 2) LO PRESS MESSAGE INOP".

OPERATIONAL PROCEDURES

Fuel Booster Pump Automatic Function Operation check:

- Airplane ENERGIZE
 - Associated Engine START
 - MFD Fuel Page SET
 - 1A (2A) Fuel Pump SELECT
 - The MFD shows A for TANK1 (TANK2).
 - 1A (2A) Fuel Pump
Circuit Breaker A1 (A34) OPEN
 - On the MFD, the indication of the related tank changes to B, C, and OFF intermittently.
 - 1A (2A) Fuel Pump
Circuit Breaker A1 (A34) CLOSE
 - The A indication comes into view on the MFD again.
 - Repeat the steps above for 1B (2B) and 1C (2C) fuel pumps. Ensure that on the MFD the indication of the related tank changes to A, C and OFF intermittently and A, B and OFF intermittently.
- Register on appropriate logbook for maintenance actions.

MAINTENANCE PROCEDURES

None.

1-09-28	Page 12	Code 02
---------	------------	------------

28-45-02 APU FUEL LOW PRESS SWITCH

Placard APU Control Panel "APU FUEL LO PRESS SWITCH INOP - DO NOT USE APU", if applicable.

OPERATIONAL PROCEDURES

Engine 2 Fuel Low Pressure Indication check:

- Airplane.....ENERGIZE
- Engine 2.....START
- MFD Fuel PageSET
- 2A Fuel PumpSELECT
- Perform the following check:
 - MFD shows A for tank 2.
 - No caution message FUEL LO PRESS displayed on the EICAS.
 - No caution light or no aural caution alarm.
- 2A Fuel Circuit Breaker (A34).....PULL
- Check the indication of the related tank changes to B, C and OFF intermittently on the MFD.
- 2A Fuel Circuit Breaker (A34).....CLOSE
- Select the 2B fuel pump and repeat the procedure.
- Select the 2C fuel pump and repeat the procedure.

MAINTENANCE PROCEDURES

None.

**DISPATCH
DEVIATIONS
PROCEDURES
MANUAL**



INTENTIONALLY BLANK

1-09-28	Page 14	Code 02
---------	------------	------------

REVISION 10

DDPM-145/1116

ATA CHAPTER 29 HYDRAULIC POWER

29-10-02 GSE COUPLINGS (EXTERNAL)

Placard the affected Plumbing "GSE COUPLING ISOLATED OR REMOVED".

OPERATIONAL PROCEDURES

None.

MAINTENANCE PROCEDURES

Perform TASK 29-10-02-040-801-A (AMM) for GSE Pressure Coupling removal and install plugs MS21913W8 (or MS21913J8) and MS21913J5 on hydraulic lines (See figure below).

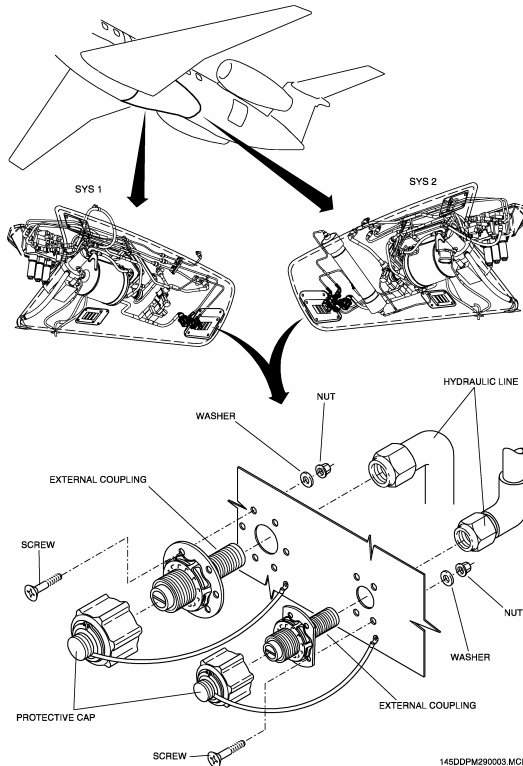



29-10-05 ELECTRIC HYDRAULIC PUMP SYSTEMS

Placard affected Electric Hydraulic Pump Control Knob "AUTO INOP" or "ON INOP".

OPERATIONAL PROCEDURES

In case of the automatic function failure, the affected pump must be turned off during cruise after gear retraction and back on prior to landing gear extension.

Pressure Indication and Electric Pump Pressure Switch check:

Before Associated Engine Start:

- Associated ELEC PUMP Knob OFF
- MFD 1 or 2 HYD PAGE
- MFD Pump Status Indication CHECK OFF
- MFD Hyd. Pressure Indication CHECK AROUND
ZERO
- Associated ELEC PUMP Knob ON
- MFD Pump Status Indication CHECK ON
- MFD Hyd. Pressure Indication CHECK WITHIN
2900 ± 200 psig
- Associated ELEC PUMP knob OFF

OFF and AUTO Position check (Manual Function Inoperative):

With associated engine shutdown:

- Associated ELEC PUMP Knob.....OFF
- MFD 1 or 2.....HYD PAGE
- MFD Pump Status Indication.....CHECK OFF
- Associated ELEC PUMP Knob.....AUTO
- MFD Pump Status Indication.....CHECK ON
- Associated Engine.....START

During associated engine START:

- N2BELOW 56%
- MFD Pump Status Indication.....CHECK ON
- N2ABOVE 56%
- MFD Pump Status Indication.....CHECK OFF

After associated engine START:

- Associated ENG PUMP SHUTOFF
 ButtonPRESS
- MFD Pump Status Indication.....CHECK ON
- Associated ENG PUMP SHUTOFF
 ButtonRELEASE
- MFD Pump Status Indication.....CHECK OFF

MAINTENANCE PROCEDURES

None.

29-10-14 RESERVOIR REFILLING CHECK VALVES

Placard the affected Plumbing "CHECK VALVE REMOVED".

OPERATIONAL PROCEDURES

None.

MAINTENANCE PROCEDURES

Perform TASK 29-10-14-040-801-A (AMM) for Check Valve removal and install plug MS21913W4 or MS21913J4 on hydraulic line (See figure below).

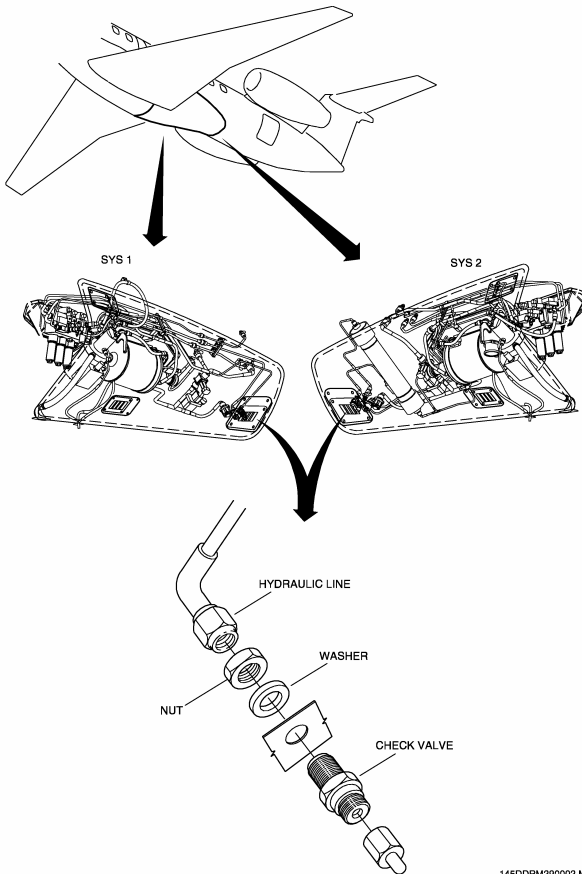

29-10-16 PRESSURE GROUND CONNECTION CHECK VALVES

Placard the affected Plumbing "CHECK VALVE REMOVED".

OPERATIONAL PROCEDURES

None.

MAINTENANCE PROCEDURES

Perform TASK 29-10-16-040-801-A (AMM) for Check Valve removal and install plugs MS21913J6 or MS21913W6 and O'ring NAS1612-6 on hydraulic line (See figure below).

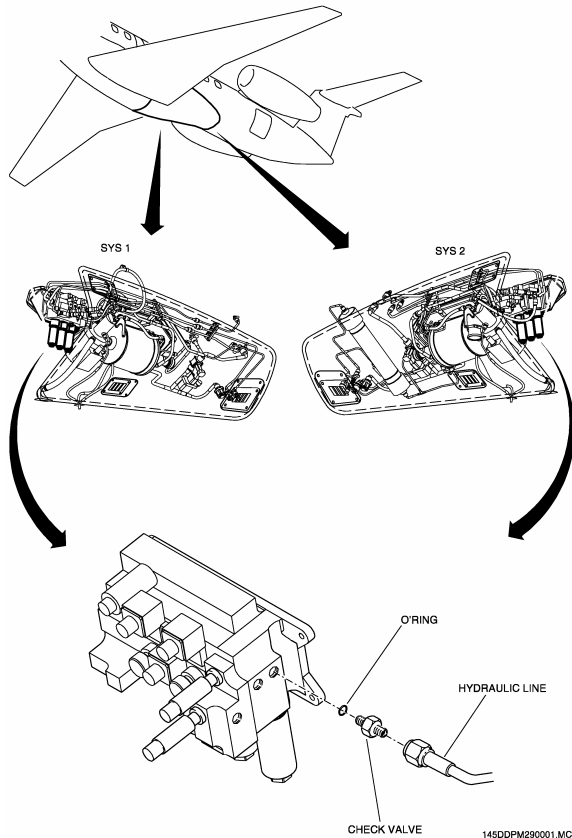

29-10-19 ENGINE-DRIVEN PUMP PRESSURE SWITCH (HYDRAULIC SYSTEM 1)

Placard affected plumbing "PRESSURE SWITCH REMOVED".

OPERATIONAL PROCEDURES

Pressure Indication and Electric Pump Pressure Switch check:

Before Associated Engine Start:

- Associated ELEC PUMP Knob OFF
- MFD 1 or 2 HYD PAGE
- MFD Pump Status Indication CHECK OFF
- MFD Hyd. Pressure Indication CHECK AROUND
ZERO
- Associated ELEC PUMP Knob ON
- MFD Pump Status Indication CHECK ON
- MFD Hyd. Pressure Indication CHECK WITHIN
2900 ± 200 psig
- Associated ELEC PUMP knob OFF

MAINTENANCE PROCEDURES

In case of fluid leakage, perform TASK 29-10-19-040-801-A (AMM) for pressure switch deactivation.

29-30-00 HYDRAULIC FLUID QUANTITY INDICATIONS (INCLUDING LOW LEVEL WARNING)

Placard MFD Bezel "HYD QTY IND INOP".

OPERATIONAL PROCEDURES

None.

MAINTENANCE PROCEDURES

Perform TASK 12-13-01-600-801-A (AMM) for Hydraulic Fluid Quantity check.

29-30-01 RESERVOIR QUANTITY GAGES

Placard affected Gage "INOP".

OPERATIONAL PROCEDURES

None.

MAINTENANCE PROCEDURES

Alternate Fluid Quantity check:

- Gain access to the affected reservoir (193BL or 193CR panel) (See figures 103 and 104 (AMM 06-41-01/101) for positive identification).
- Remove the vent filter (cut the lockwire and remove both screws).
- Ensure Landing Gear/Main Door and Emergency/Parking Brake accumulators have a pre-charge of nitrogen only (refer to AMM TASK 32-44-02-700-801-A SUBTASK 32-44-02-720-001-A00 and TASK 52-12-00-700-802-A SUBTASK 52-12-00-720-001-A00).
- Insert a small rod in the vent filter hole deep enough to contact the piston head (in order to measure piston displacement).
- Make sure piston displacement is at or below 30 mm.
- If displacement is above 30 mm, perform TASK 12-13-01-600-802-A (AMM) to replenish the reservoir.
- Install and lockwire the vent filter.

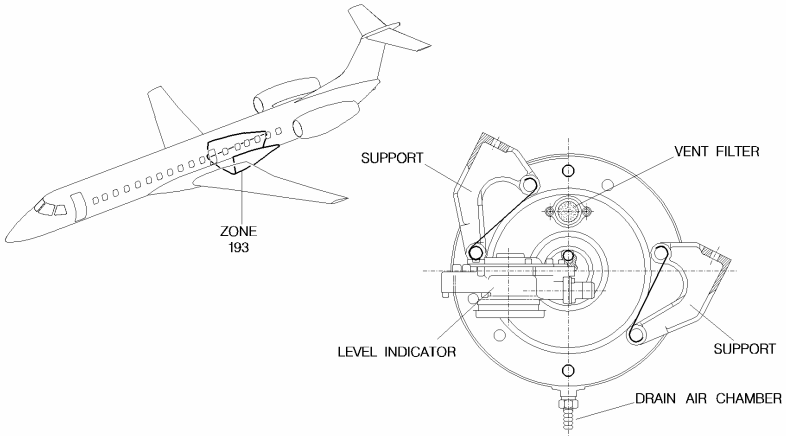

FRONT VIEW

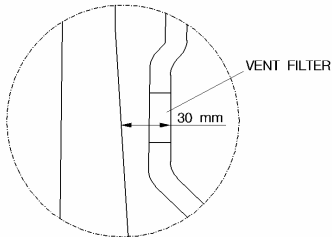
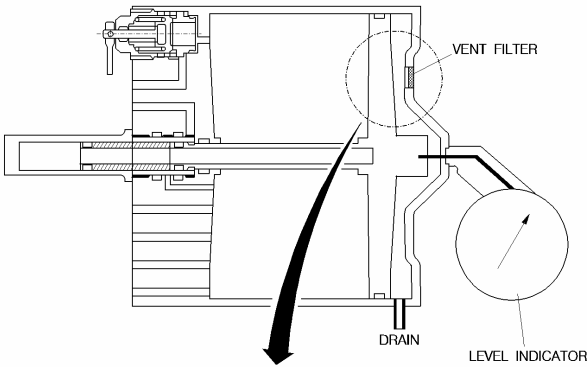

145116001.MCE

29-30-02 HYDRAULIC PRESSURE INDICATIONS

Placard MFD Bezel "HYD SYS 1 (OR 2) PRESS IND INOP".

OPERATIONAL PROCEDURES

HYD SYS FAIL Caution Message operation check:

- Landing Gear Ground Locking Pins INSERT
- Associated Engine..... START
- Air/Ground Circuit
Breakers (A5, A29, E17 and E18) PULL
- Associated ELEC PUMP knob OFF
- Associated ENG PUMP SHUTOFF Button PRESS
- Associated HYD SYS FAIL Message..... CHECK ON
- Associated ENG PUMP SHUTOFF Button RELEASE
- Air/Ground Circuit
Breakers (A5, A29, E17 and E18) CLOSE
- Associated HYD SYS FAIL Message..... CHECK OFF

MAINTENANCE PROCEDURES

None.



29-30-04 ELECTRIC PUMP PRESSURE SWITCH (HYDRAULIC SYSTEM 1)

Placard the affected plumbing "PRESSURE SWITCH REMOVED".

OPERATIONAL PROCEDURES

Pressure Indication and Engine Driven Pump Pressure Switch check:

Before associated engine start:

- Associated ELEC PUMP Knob OFF
- MFD 1 or 2 HYD PAGE
- MFD Pump Status Indication CHECK OFF
- MFD Hyd. Pressure Indication CHECK AROUND
ZERO
- Associated ELEC PUMP Knob AUTO
- MFD Pump Status Indication CHECK ON
- MFD Hyd. Pressure Indication CHECK WITHIN
2900 ± 200 psig

During associated engine start:

- N2 BELOW 56%
- MFD Pump Status Indication CHECK ON
- N2 ABOVE 56%
- MFD Pump Status Indication CHECK OFF

After associated engine start:

- Associated ENG PUMP SHUTOFF Button PRESS
- MFD Pump Status Indication CHECK ON (after
pressure drops to
1600 psig)
- Associated ENG PUMP SHUTOFF Button RELEASE
- MFD Pump Status Indication CHECK OFF

NOTE: After pressing the ENG PUMP SHUTOFF Button, pressure will take a while to drop to a value at which the Electric Pump will be automatically switched ON. This value can be as low as 1250 psig.

MAINTENANCE PROCEDURES

In case of fluid leakage, perform TASK 29-30-04-040-801-A (AMM) for pressure switch removal.

1-09-29	Page 10	Code 02
---------	------------	------------



**DISPATCH
DEVIATIONS
PROCEDURES
MANUAL**

ATA CHAPTER 30
ICE/RAIN
PROTECTION

**ATA CHAPTER 30 ICE AND RAIN
PROTECTION**

30-11-00 WING ANTI-ICING SYSTEM

Placard Ice Protection Panel "WING SYSTEM INOP".

OPERATIONAL PROCEDURES

None.

MAINTENANCE PROCEDURES

None.

DDPM-145/1116

REVISION 9

1-09-30	Page 1	Code 02
---------	-----------	------------

30-11-01 WING ANTI-ICING VALVES

Placard above Wing Anti-icing Button "INOP".

OPERATIONAL PROCEDURES

None.

MAINTENANCE PROCEDURES

Wing/Stabilizer Anti-ice Valve secured closed:

For Airplanes Pre-Mod. SB 145-30-0021:

- Gain access to the valve through respective access panels (191EL - LH side, or 191FR - RH side. See AMM 6-41-01).
- With the position indicator in the STOW position, loosen the lock bolt.
- Rotate the valve to the LOCK position (Align the position indicator hole with the cover assembly threaded hole by using a 1/4" socket or end wrench on the exposed valve shaft).
- Retighten the lock bolt and torque it until there is a 0.25 to 1.25 mm gap between the under side of the bolt head and the top surface of the position indicator.

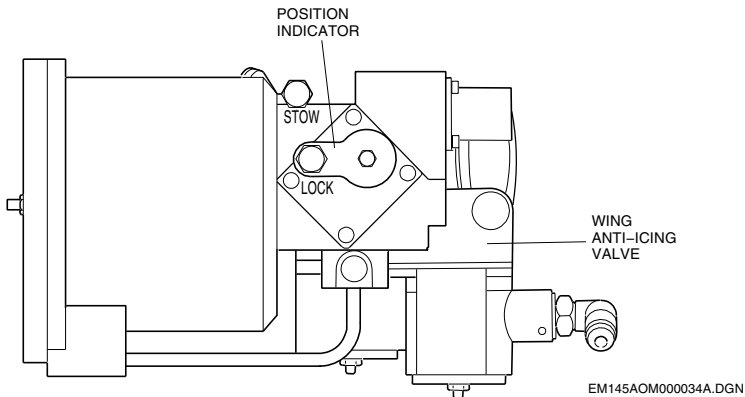

WING/STABILIZER ANTI-ICE VALVE (PRE-MOD. SB 145-30-0021)

1-09-30	Page 2	Code 02
---------	-----------	------------

REVISION 9

For Airplanes Post-Mod. SB 145-30-0021:

- Gain access to the valve through respective access panels (191EL - LH side, or 191FR - RH side. See AMM 6-41-01).
- With the anti-icing valve deenergized, the actuator pressure is vented to ambient and the valve is in the closed position. The position indicator is directed to "CL" on the valve housing.
- Remove the chained lock screw to vent servo and install the screw in the threaded hole (see figure) with the position indicator directed to "CL".
- Rotate the valve to the "CL" position (Align the position indicator hole with the cover assembly threaded hole by using a 1/4" socket or end wrench on the exposed valve shaft).
- Bottom screw in boss and wrench the lock screw to locked position to a maximum of 8 ft-lb.
- For quick reference, locking instructions are printed on the valve instruction plate.

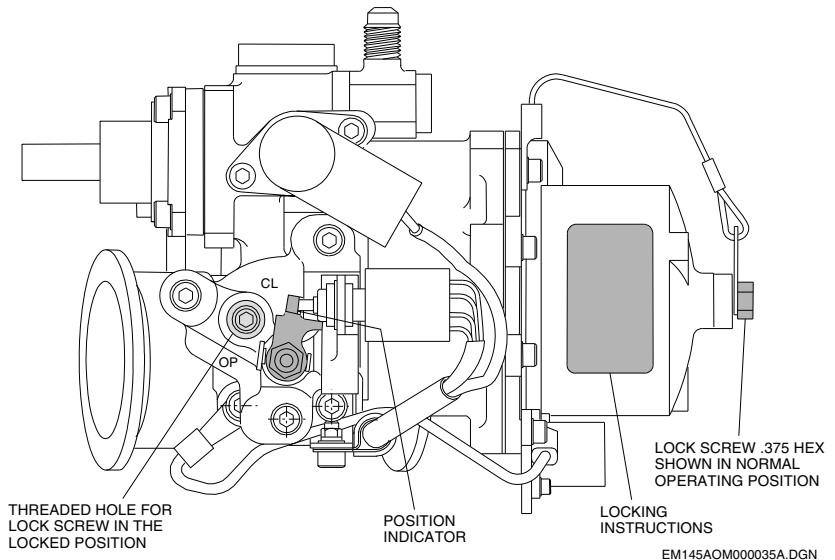

WING/STABILIZER ANTI-ICE VALVE (POST-MOD. SB 145-30-0021)

DDPM-145/1116

REVISION 9

1-09-30	Page 3	Code 02
---------	-----------	------------

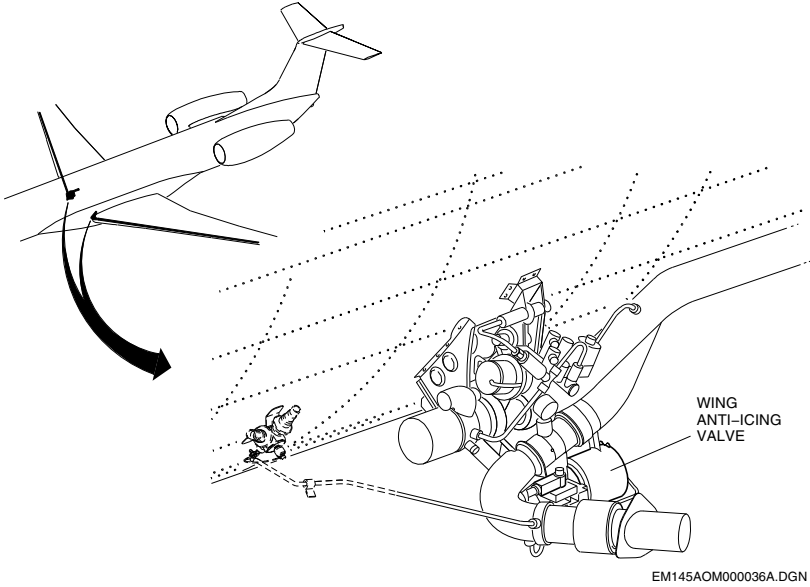

**WING ANTI-ICE VALVE LOCATION
(PRE-MOD. AND POST-MOD. SB 145-30-0021)**

30-11-02 WING ANTI-ICING VALVE OPEN LIGHT

Placard above Wing Anti-Icing Button "OPEN LIGHT INOP".

OPERATIONAL PROCEDURES

None.

MAINTENANCE PROCEDURES

Perform TASK 30-00-00-700-803-A (AMM) for wing thermal anti-icing system operational check.

30-12-00 STABILIZER ANTI-ICING SYSTEM

Placard Ice Protection Panel "STAB. SYSTEM INOP".

OPERATIONAL PROCEDURES

None.

MAINTENANCE PROCEDURES

None.

30-12-01 STABILIZER ANTI-ICING VALVE

Placard above Stabilizer Anti-icing Button "INOP".

OPERATIONAL PROCEDURES

None.

MAINTENANCE PROCEDURES

Refer to item 30-11-01 for valve secured closed procedure. To gain access to this valve, remove access panel 322AL (see AMM 6-42-00).



30-12-02 STABILIZER ANTI-ICING VALVE OPEN LIGHT

Placard above Stabilizer Anti-Icing Button "OPEN LIGHT INOP".

OPERATIONAL PROCEDURES

None.

MAINTENANCE PROCEDURES

Perform TASK 30-00-00-700-803-A (AMM) for horizontal stabilizer thermal anti-icing system operational check.

30-21-00 ENGINE ANTI-ICING SYSTEMS

Placard Ice Protection Panel "ENGINE SYSTEM INOP".

OPERATIONAL PROCEDURES

None.

MAINTENANCE PROCEDURES

None.

1-09-30	Page 6	Code 02
---------	-----------	------------

30-21-01 ENGINE ANTI-ICING VALVES

Placard above Engine Anti-icing Button "INOP".

OPERATIONAL PROCEDURES

For airplanes equipped with AE3007A, AE3007A1/1, AE3007A1, AE3007A1E, AE3007A1/3 and AE3007A1P engines - AE3007A and AE3007A1/1 engines intermix operation is also permitted:

The following procedures must be accomplished when dispatching the airplane with one or both engine anti-icing valves locked open:

NOTE: The associated E1 (2) A/ICE FAIL message may be present throughout the flight unless the Ice Detection Override Knob is set to ENG or ALL. If this message persists with the knob in ENG or ALL, follow the associated QRH procedure or report to the maintenance personnel, as applicable.

Takeoff Data Setting:

- Set REF A/I ON, so the FADECs properly command the correct thrust if one or two engine valves are locked open.
- Operate the Ice Detection Override normally: ENG in icing conditions, AUTO not in icing conditions.
- REF A/I DISAG message will be inhibited only when both engine anti-ice valves are locked open with REF A/I ON and ENG selected, otherwise the message may appear.

Takeoff Weights Corrections:

The takeoff weight correction should be accomplished according one of the following criteria:

- Run the ETOAS with the Anti-ice option set to "FAIL", or
- Reduce the MTOW by:
 - a) 794 lb (AE3007A, AE3007A1/1 or AE3007A1 engines).
 - b) 587 lb (AE3007A1E engine).
 - c) 508 lb (AE3007A1P or AE3007A1/3 engines).



- NOTE:** – In case of discrepancies between the MTOW calculated through Runway Analysis Software and the MTOW reduced by xx lb (depending on the engine), the value given by Software must prevail.
- For airplanes equipped with AE3007A, AE3007A1/1 and AE3007A1 engines, only T/O-1 mode is allowed for takeoff with engine anti-ice valve locked open.
 - For airplanes equipped with AE3007A1P and AE3007A1/3 engines, only T/O mode is allowed for takeoff with engine anti-ice valve locked open.
 - For airplanes equipped with AE3007A1E engine, only T/O and E T/O mode are allowed for takeoff with engine anti-ice valve locked open.

Speeds Corrections:

There are no speed corrections associated with engine anti-ice valve locked.

Enroute and Landing Weights Corrections:

Use applicable AFM supplement performance charts to calculate enroute and landing weights when operating with engine anti-ice locked open.

MAINTENANCE PROCEDURES

- Perform TASK 30-21-05-200-802-A (AMM) for Engine Anti-Ice Valve check.

Engine Anti-ice Valve secured open:

- Remove the following access panels (AMM 06-43-00/101):
 - 412AT (Upper cowling of the LH powerplant) and
 - 422AT (Upper cowling of the RH powerplant);
- Loosen both lock screws (approximately one turn);
- Press and rotate the manual override pin 270° as indicated to lock valve in the open position;
- Tighten both lock screws.
- Close the following access panels (AMM 06-43-00/101):
 - 412AT (Upper cowling of the LH powerplant) and
 - 422AT (Upper cowling of the RH powerplant).

1-09-30	Page 8	Code 02
---------	-----------	------------



DISPATCH DEVIATIONS PROCEDURES MANUAL

ATA CHAPTER 30
ICE/RAIN
PROTECTION

- NOTE:** - The message ENG A/ICE OVERPRES may be present.
- The message ENG NO ICE-A/ICE ON may be present.
- In case of engine anti-ice valve secured open and associated engine anti-icing OPEN light inoperative, the airplane may be dispatched.

DDPM-145/1116

REVISION 11

1-09-30	Page 9	Code 02
---------	-----------	------------

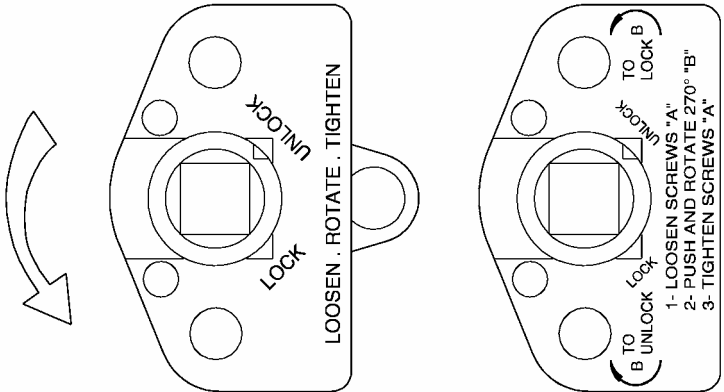
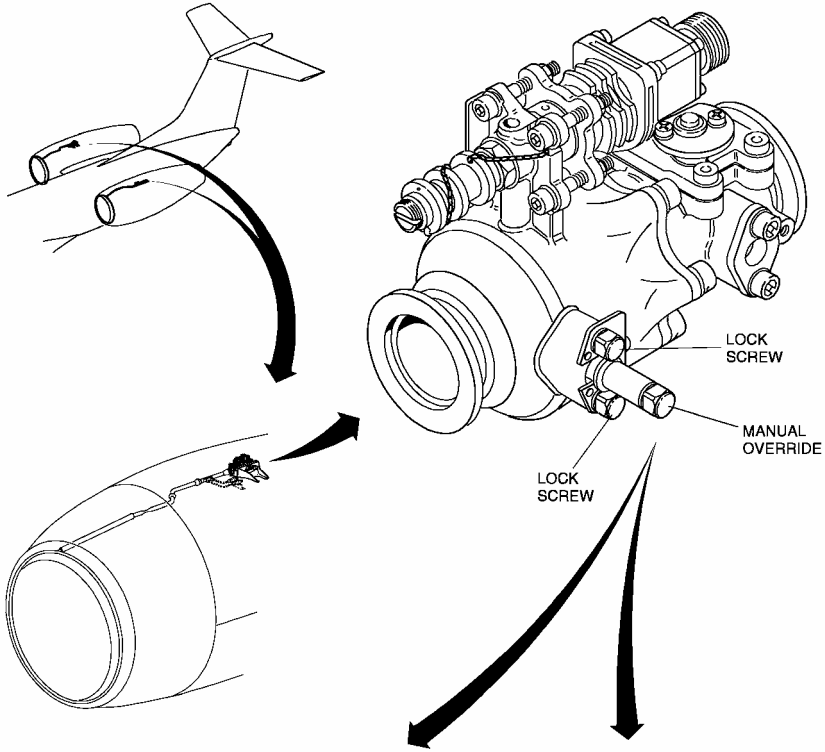

145DDPM300001.MCE

ENGINE ANTI-ICING VALVE

30-21-02 ENGINE ANTI-ICING VALVE OPEN LIGHT

Placard above Engine Anti-Icing Buttons "OPEN LIGHT INOP".

OPERATIONAL PROCEDURES

None.

MAINTENANCE PROCEDURES

Perform TASK 20-13-04-000-801-A (AMM) (removal) and TASK 20-13-04-400-801-A (AMM) (installation) to swap the pushbuttons of Engine Air Inlet 1 and Engine Air Inlet 2. After swapping the pushbuttons, perform TASK 30-21-00-700-804-A (AMM) for Engine Anti-Icing Valve Operational Test.

NOTE: The intention of the accomplishment of these tasks above is to confirm the failure of the OPEN indication light and the proper operation of the engine anti-ice valve.

30-31-00 PITOT/STATIC HEATING SYSTEMS

Placard above Pitot/Static Heating Button "PITOT HEAT INOP".

OPERATIONAL PROCEDURES

None.

MAINTENANCE PROCEDURES

NOTE: - For MMEL dispatch purposes, the Pitot/Static Heating system is comprised of: Pitot Tube Heating, Pitot/Static Heating and Static Port Heating.

- Pitot System 1 = Pitot 1 (P1) + Static 1 (S1).
- Pitot System 2 = Pitot 2 (P2) + Static 2 (S2).
- Pitot System 3 = P/S3 (pitot +static) (standby).

Pitot/Static Heating Operational Check:

May be flight crewmember accomplished.

After engine start:

Check no caution message associated to the remaining static ports heating after any engine achieves 65% N2.



30-31-03 PITOT LINES HEATER

Placard as appropriate.

OPERATIONAL PROCEDURES

None.

MAINTENANCE PROCEDURES

None.

30-32-01 AOA SENSOR HEATING SYSTEMS

Placard above AOA Heating Button "AOA HEAT INOP".

OPERATIONAL PROCEDURES

None.

MAINTENANCE PROCEDURES

None.

30-33-01 TAT PROBE HEATING SYSTEMS

Placard above TAT Heating Button "TAT HEAT INOP".

OPERATIONAL PROCEDURES

None.

MAINTENANCE PROCEDURES

None.

30-41-00 WINDSHIELD WIPERS

Placard Windshield Wiper Selector Knob "INOP" or "LOW INOP" or "HIGH INOP" or "TIMER INOP".

OPERATIONAL PROCEDURES

According to the MMEL remarks.

MAINTENANCE PROCEDURES

None.

1-09-30	Page 12	Code 02
---------	------------	------------

30-41-04 RAIN REPELLENT COATING

Placard as appropriate.

OPERATIONAL PROCEDURES

None.

MAINTENANCE PROCEDURES

None.

30-42-02 WINDSHIELD HEATING SYSTEMS

Placard Windshield Heating Control Panel "SYSTEM INOP".

OPERATIONAL PROCEDURES

None.

MAINTENANCE PROCEDURES

May be flight Crewmember accomplished. Pull and safety the WSHLD TEMP circuit breaker associated with the inoperative windshield (G13 or J20).

30-80-00 ICE DETECTORS

Placard Ice Detection Override Knob "ICE DET 1 (or 2) INOP".

OPERATIONAL PROCEDURES

Set the Ice Detection Override Knob to ALL position at the first visible or anticipated icing condition.

NOTE: - Icing conditions may exist inflight when Total Air Temperature (TAT) is 50°F or below and visible moisture in any form is presented (such as clouds, fog with visibility of one mile or less, rain, snow, sleet and ice crystals).

- For ice protection test A or B, as described on Airplane Operations Manual (AOM) section 1-02-79, the message ICE DETECTORS FAIL will be present.

MAINTENANCE PROCEDURES

None.



30-81-01 CLEAR ICE DETECTOR SYSTEM

Placard Clear Ice Detector Control Panel "CLEAR ICE DETECT SYS INOP" or placard Clear Ice Indication Lights "INOP".

OPERATIONAL PROCEDURES

CLR/I INOP 1 (2) EICAS messages check:

Perform the following test before engines start:

Ice Detection Override Knob.....AUTO

Ice Detection Test Knob1

Test knob must be held at least 10 seconds in this position.

Check that CLR/I INOP 1 and CLR/I INOP 2 caution messages are displayed on the EICAS.

NOTE: If Ice Detection Test Knob 2 is selected, these messages will not be displayed on the EICAS.

Upper wing surface check:

A physical (hands-on) check must be done on the upper wing surface to ensure that there is no clear ice built up on the wing.

The check may be accomplished by either the maintenance personnel or the flight crew.

This inspection must be accomplished after the airplane is refueled and as near the departure as possible.

Perform the check as follows:

- The check must be performed on the upper surface of the wing, close to the wing-to-fuselage junction, in the region where the clear ice detector is installed.
- Position a ladder close to the wing leading edge. Check for the presence of ice by feeling the upper wing surface along and aft the front spar.
- Check the wing surface in the area over the clear-ice sensor and on the anti-slip stripes. The sharp parts of the granules in the stripes and the clear-ice sensor screw heads must be touched. They have a consistent rough texture. The anti-slip stripes and the Exit direction arrow may be used as visual reference as well.
- If clear ice is found, de-ice the airplane.

MAINTENANCE PROCEDURES

None.

1-09-30	Page 14	Code 02
---------	------------	------------

(Pages 15 and 16 deleted)

REVISION 11

DDPM-145/1116

ATA CHAPTER 31 INDICATING/RECORDING SYSTEMS

31-21-01 CLOCKS

Placard affected Clock "INOP".

OPERATIONAL PROCEDURES

None.

MAINTENANCE PROCEDURES

None.

31-30-01 FLIGHT DATA RECORDER (FDR) SYSTEM

Placard near Clock's Multiple Selector "FDR INOP".

OPERATIONAL PROCEDURES

None.

MAINTENANCE PROCEDURES

None.



31-42-02 INTEGRATED COMPUTER CONFIGURATION MODULES (IM-600)

OPERATIONAL PROCEDURES

None.

MAINTENANCE PROCEDURES

None.

31-51-00 AURAL WARNING UNIT

Report to the maintenance personnel.

OPERATIONAL PROCEDURES

None.

MAINTENANCE PROCEDURES

None.

31-51-02 MASTER WARNING LIGHTS/BUTTONS

Placard associated Light "LIGHT INOP" or "ALARM CANCEL INOP".

OPERATIONAL PROCEDURES

None.

MAINTENANCE PROCEDURES

None.

1-09-31	Page 2	Code 02
---------	-----------	------------



DISPATCH DEVIATIONS PROCEDURES MANUAL

ATA CHAPTER 31
INDICATING/
RECORDING

31-51-03 MASTER CAUTION LIGHTS/BUTTONS

Placard associated Light "LIGHT INOP" or "ALARM CANCEL INOP".

OPERATIONAL PROCEDURES

None.

MAINTENANCE PROCEDURES

None.

DDPM-145/1116

REVISION 9

1-09-31	Page 3	Code 02
---------	-----------	------------

**DISPATCH
DEVIATIONS
PROCEDURES
MANUAL**



INTENTIONALLY BLANK

1-09-31	Page 4	Code 02
---------	-----------	------------

REVISION 9

DDPM-145/1116

ATA CHAPTER 32 LANDING GEAR

32-33-02 LANDING GEAR CONTROL LEVER LATCH SYSTEM

Placard Landing Gear Control Box "LATCH SYSTEM INOP".

OPERATIONAL PROCEDURES

After takeoff, use the Downlock Release button to actuate the Landing Gear Lever to UP.

MAINTENANCE PROCEDURES

NOTE: If the operational procedure was accomplished previously during flight, the override mechanism check does not need to be accomplished.

Override Mechanism check:

- Install safety pins on the three LG legs.
- Pull the overhead panel landing gear circuit breakers A30 "CMD" and E21 "DOOR CMD".
- Try to move the landing gear lever up. The landing gear lever shall be latched in the down position.
- Press the DOWN LOCK REL button and try to move the landing gear lever to UP. The lever should move to UP position.
- Return the LG control lever to Down position.
- Restore the airplane to normal condition.

NOTE: Visually check the landing gear shock absorbers for condition and leakage.



32-40-01 BRAKE TEMPERATURE INDICATIONS

Placard MFD Bezel "BRAKE XX IND INOP" or "BRAKE INDICATIONS INOP".

OPERATIONAL PROCEDURES

See Quick Turn Around Weight Chart on AOM Section 1-04-30 - Performance.

MAINTENANCE PROCEDURES

In order to deactivate each affected Brake Temperature Sensor independently, follow the steps below:

- Pull the affected Brake Temperature Sensor circuit breaker and attach a DO-NOT-CLOSE tag to it:

TEMPERATURE SENSOR	CIRCUIT BREAKER
RH and LH Inboard	E19
RH and LH Outboard	E16

- Open the access panel 193AL (For EMB-145XR, 197DR and 197CL). Refer to the AMM 06-41-01/101.
- Disconnect the electrical connector associated to the failed Brake Temperature Sensor:

TEMPERATURE SENSOR	LH OUTBD	LH INBD	RH INBD	RH OUTBD
CONNECTOR	P1075	P1077	P1076	P1078

- Secure the harness associated with the disconnected connector with an appropriate tie-wrap in order to prevent it from moving freely within the fairing area.
- Install a cap (P/N MS90376-16Y or P/N NAS820-16A) in the electrical connector. Lock wire can be used to hold the cap in its place, if there is no confidence that it will be held during the airplane operation.
- Install a cap (P/N MS90376-12RB or P/N NAS831-12C) in the affected Brake Temperature Signal Conditioner.

- Push back in the affected Brake Temperature Sensor circuit breaker (E16 or E19) and remove the DO-NOT-CLOSE tag from it.

NOTE: If two or more Brake Temperature Sensors are disconnected, see Quick Turn Around Weight Chart on AOM Section 1-04-30 - Performance.

In order to deactivate two or all Brake Temperature Sensors, pull and collar the affected sensor circuit breaker:

- May be flight crewmember accomplished. Pull the affected Brake Temperature Sensor circuit breaker and attach a DO-NOT-CLOSE tag to it:

TEMPERATURE SENSOR	CIRCUIT BREAKER
RH and LH Inboard	E19
RH and LH Outboard	E16

32-41-08 BRAKE PRESSURE TRANSDUCERS

Register as appropriate for maintenance actions.

OPERATIONAL PROCEDURES

None.

MAINTENANCE PROCEDURES

Brake Pressure Transducer deactivation:

- For brake pressure transducer access refers TASK 32-41-08-000-801-A (AMM).
- Gain access to the affected pressure transducer.
- Disconnect and stow the electrical connector.
- Make sure there is no evidence of leakage on the pressure port connection.

32-44-05 ACCUMULATOR LOW PRESSURE SWITCH

Placard on EICAS Bezel "EMRG BR LO PRES MESSAGE INOP".

OPERATIONAL PROCEDURES

None.

MAINTENANCE PROCEDURES

Perform TASK 32-44-05-040-801-A (AMM) for Emergency/Parking Brake Accumulator Charge check.

32-44-07 BRAKE ON LIGHTS

Placard affected Light "INOP".

OPERATIONAL PROCEDURES

None.

MAINTENANCE PROCEDURES

May be flight crewmember accomplished.

Parking Brake System check:

- Shut engines down and chock the airplane.
- Use APU or GPU as electrical power supply.
- Set both Thrust Levers at IDLE position.
- Turn on hydraulic system 2 electric pump.

CAUTION: NEVER MOVE CONTROL SURFACES SUCH AS FLAPS AND SPOILERS WITHOUT FIRST MAKING SURE THAT THE AREA IS CLEAR.

- Set flap to position 9° and set pitch trim within the takeoff green band limits.
- Cycle Parking Brake handle, while a second person checks that the brake actuating pistons of all brake assemblies are in operation.
- Release Parking Brakes.
- Advance Thrust levers to MAX position.
- Check that the Voice Message TAKEOFF BRAKES does not sound and the EICAS message NO TAKEOFF CONFIG is not presented.
- Apply Parking Brake and check that the Voice Message TAKEOFF BRAKES sounds and the EICAS Message NO TAKEOFF CONFIG is presented.
- Retard power lever, set flap position to 0° and turn off the hydraulic pump.



32-49-00 BRAKE ASSEMBLY WEAR INDICATOR

Placard as appropriate.

OPERATIONAL PROCEDURES

None.

MAINTENANCE PROCEDURES

Perform TASK 32-49-03-200-801A (AMM) (Brake Assembly – Inspection) once for each flight day.

32-50-00 EXTERNAL STEERING DISENGAGEMENT SWITCH

Placard External Steering Disengagement Switch "INOP".

OPERATIONAL PROCEDURES

According to the MMEL remarks.

MAINTENANCE PROCEDURES

None.

1-09-32	Page 6	Code 02
---------	-----------	------------

32-50-02 CONTROL WHEEL STEERING DISENGAGE BUTTONS

Placard on the pilot's console near the steering handle "PILOT FLYING'S CONTROL WHEEL STEERING DISENGAGE BUTTON INOP".

OPERATIONAL PROCEDURES

None.

MAINTENANCE PROCEDURES

May be flight crewmember accomplished.

Pilot Not Flying's Control Wheel Steering Disengage Button check:

- Perform SUBTASK 32-50-00-841-001-A00 (AMM) for airplane preparation.
- Press the pilot not flying steering disengage button (STEER DISC) on the control wheel.
- Check STEER INOP caution message comes into view.
- Move the pedals from full right to full left and check RUDDER movement associated with no steering command. Make sure that the wheels do not move when the pedal is operated.
- Press the steering handle to reconnect the steering.
- Check STEER INOP caution message goes out of view.

32-60-00 LANDING GEAR PROXIMITY SWITCHES

Register as appropriate for maintenance actions.

OPERATIONAL PROCEDURES

None.

MAINTENANCE PROCEDURES

Proximity Switch check:

To check the proximity switch refer to TASK 32-63-05-700-801-A (AMM).

**DISPATCH
DEVIATIONS
PROCEDURES
MANUAL**



INTENTIONALLY BLANK

1-09-32	Page 8	Code 02
---------	-----------	------------

Copyright © by Embraer. Refer to cover page for details.

REVISION 9

DDPM-145/1116

ATA CHAPTER 33 LIGHTS

33-10-00 COCKPIT / FLIGHT DECK / FLIGHT COMPARTMENT AND INSTRUMENT LIGHTING SYSTEMS

Placard associated Light or Switch "INOP".

OPERATIONAL PROCEDURES

None.

MAINTENANCE PROCEDURES

None.

33-20-00 CABIN INTERIOR ILLUMINATION SYSTEM

Placard the Cabin Lighting Control Buttons, at the Attendant's Panel "INOP - DO NOT TURN ON".

OPERATIONAL PROCEDURES

According to the MMEL remarks.

MAINTENANCE PROCEDURES

May be flight Crewmember accomplished. The overhead ceiling and sidewall lighting may contain inoperative lights not to exceed more than 10% of the total quantity, and no more than two adjacent lamps in the longitudinal or lateral direction may be inoperative. Adjacent lamps are those next to or diagonally opposing lamps. The figure below represents possible scenarios with three adjacent row of lighting. Other scenarios are possible and the figure is for guidance only. Inoperative lamps bulbs are marked with "X". Each column represents a single overhead bulb. All inoperative lamps must be clear of galley, cabinets and life-raft storage areas.

DISPATCH
DEVIATIONS
PROCEDURES
MANUAL



ACCEPTABLE

	X	X
	X	X

		X
		X
	X	

	X	
		X

UNACCEPTABLE

X		
	X	
X		

	X	
	X	
X		

X	X	
	X	

145AOM1090008.MCE

33-21-02 COCKPIT STERILE LIGHT

Placard Sterile Light Button "INOP".

OPERATIONAL PROCEDURES

Notify cabin attendant that sterile light is inoperative and use the service interphone system to advise when the cockpit is to be shut out.

MAINTENANCE PROCEDURES

None.

33-23-00 PASSENGER SIGNS

Placard the seats affected by the inoperative signs "DO NOT OCCUPY".

OPERATIONAL PROCEDURES

Prior to each flight the Captain must verify that the Passenger Address system operates normally and the Flight Attendant is briefed that this system must be used to notify the Flight Attendant and passengers when seats belts must be used, and smoking is prohibited.

MAINTENANCE PROCEDURES

May be flight crewmember accomplished. Verify that NO SMOKING/FASTEN SEAT BELT sign is readily available for affected seat. If the sign is not readily available, block seat(s) and placard "DO NOT OCCUPY".

33-26-00 COURTESY AND STAIRS LIGHTING SYSTEM

Placard Courtesy Lights Panel "INOP".

OPERATIONAL PROCEDURES

None.

MAINTENANCE PROCEDURES

None.

33-30-00 COMPARTMENT LIGHTS (NOSE, TAIL, ETC)

Placard associated Light "INOP".

OPERATIONAL PROCEDURES

None.

MAINTENANCE PROCEDURES

None.

33-41-00 LANDING LIGHTS

Placard affected Landing Light Switch "INOP".

OPERATIONAL PROCEDURES

Flight crew to extinguish light manually after gear retraction.

MAINTENANCE PROCEDURES

None.

33-42-00 TAXI LIGHT

Placard Taxi Lights Switch "ONE or BOTH LT INOP".

OPERATIONAL PROCEDURES

Flight crew to extinguish light manually after gear retraction.

MAINTENANCE PROCEDURES

None.



DISPATCH DEVIATIONS PROCEDURES MANUAL

ATA CHAPTER 33
LIGHTS

INTENTIONALLY BLANK

DDPM-145/1116

REVISION 9

1-09-33	Page 5	Code 02
---------	-----------	------------



33-43-00 NAVIGATION LIGHTS

In case of both systems failure, placard Navigation Light Switch "INOP".

OPERATIONAL PROCEDURES

None.

MAINTENANCE PROCEDURES

Wingtip Lights (Green & Red):

May be flight crewmember accomplished. Set the NAV LIGHT switch, on the maintenance panel (behind the pilot's seat), to the NORM or STBY position to select the system which is operative (See Figure).

White Lights (only applicable to airplanes equipped with Four White Navigation Lights):

May be flight crewmember accomplished. Set the NAV LIGHT switch, on the aft ramp hail panel (See Figure), to the NORM or STBY position, in case one or both of the tail navigation lights in use become(s) inoperative.

1-09-33	Page 6	Code 02
---------	-----------	------------

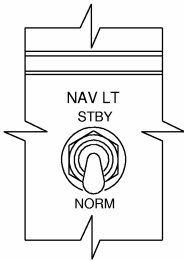
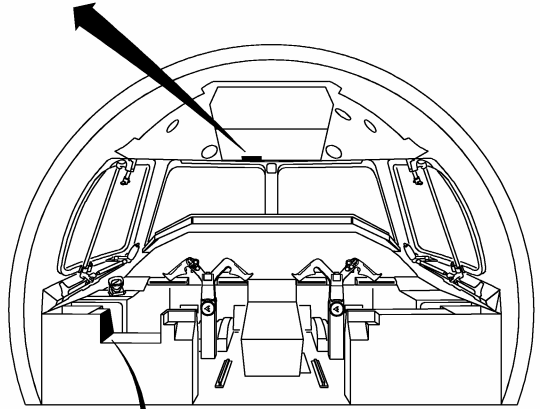
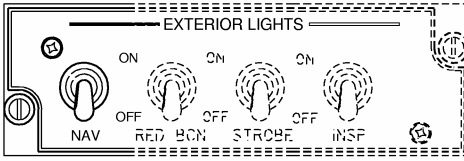

MAINTENANCE PANEL

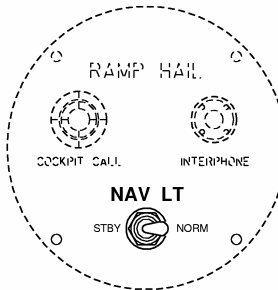
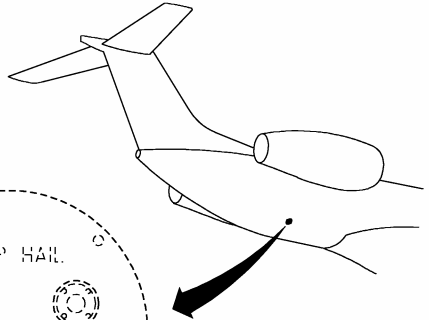

145AOM1090003.MCE

NAVIGATION LIGHTS CONTROL PANELS

DDPM-145/1116

REVISION 9

1-09-33	Page 7	Code 02
---------	-----------	------------

33-44-00 WING INSPECTION LIGHTS

Placard INSP Light Switch "INOP".

OPERATIONAL PROCEDURES

None.

MAINTENANCE PROCEDURES

None.

33-46-00 LOGO LIGHTS

Placard LOGO Light Switch "INOP".

OPERATIONAL PROCEDURES

None.

MAINTENANCE PROCEDURES

None.

33-47-03 STROBE LIGHTS

Placard STROBE Switch "INOP".

OPERATIONAL PROCEDURES

None.

MAINTENANCE PROCEDURES

None.

33-47-05 RED BEACON LIGHTS

Placard RED BCN Light Switch "INOP".

OPERATIONAL PROCEDURES

Before Starting Engines or APU:

Strobe Switch.....AS REQUIRED

For night operation, use strobe lights as a beacon to warn the ground personnel. For day operation, strobe lights are not required.

Red Beacon SwitchON

Set Red Beacon Switch to ON position before engine start to turn FDR on.

Check carefully if the engines area is clear before starting engines.

NOTE: Red Beacon system could be disabled (pull and safety the RED BEACON (H19) circuit breaker), at operators discretion, and FDR system still operates normally.

MAINTENANCE PROCEDURES

None.

33-48-00 BAGGAGE DOOR EXTERNAL LIGHT

Placard Baggage Door External Switch "LIGHT INOP".

OPERATIONAL PROCEDURES

None.

MAINTENANCE PROCEDURES

None.



33-50-00 EMERGENCY LIGHTING SYSTEM (BATTERY-POWERED)

Placard Emergency Light Switch "SYSTEM INOP".

OPERATIONAL PROCEDURES

None.

MAINTENANCE PROCEDURES

None.

33-50-01 PHOTOLUMINESCENT FLOOR PROXIMITY EMERGENCY ESCAPE PATH MARKING SYSTEM

OPERATIONAL PROCEDURES

None.

MAINTENANCE PROCEDURES

None.

1-09-33	Page 10	Code 02
---------	------------	------------

ATA CHAPTER 34 NAVIGATION

34-22-01 MAIN PANEL DISPLAYS

Placard the affected Display "INOP".

OPERATIONAL PROCEDURES

None.

MAINTENANCE PROCEDURES

If the EICAS display or either the flying pilot MFD or PFD display becomes inoperative, exchange its entire Display Unit with non-flying pilot MFD Display Unit and pull and safety affected Display Unit CB. Perform TASK 34-22-01-000-801-A (AMM) for Display Unit removal and TASK 34-22-01-400-801-A (AMM) for installation.

NOTE: The flying pilot PFD and MFD must be operative.

34-22-02 TAT INDICATIONS

Placard MFD Bezel "TAT INOP".

OPERATIONAL PROCEDURES

None.

MAINTENANCE PROCEDURES

None.

34-22-03 SAT INDICATIONS

Placard MFD Bezel "SAT INOP".

OPERATIONAL PROCEDURES

None.

MAINTENANCE PROCEDURES

None.

34-24-01 STANDBY ATTITUDE INDICATION (ON INTEGRATED STANDBY INSTRUMENT (ISIS) OR ON DEDICATED INSTRUMENT)

Placard Standby Attitude Indicator "INOP".

OPERATIONAL PROCEDURES

None.

MAINTENANCE PROCEDURES

None.

34-24-02 STANDARD BAROMETRIC PRESSURE (STD) BUTTON ON ISIS

Placard adjacent to ISIS "STD BUTTON INOP".

OPERATIONAL PROCEDURES

None.

MAINTENANCE PROCEDURES

None.

34-25-00 HEAD-UP GUIDANCE SYSTEM (HGS)

Placard Head-Up Guidance System Control Panel (HCP) "HGS INOP".

OPERATIONAL PROCEDURES

None.

MAINTENANCE PROCEDURES

None.

34-25-01 STANDBY MAGNETIC COMPASS

Placard Standby Magnetic Compass "INOP".

OPERATIONAL PROCEDURES

As required to meet the MMEL remarks.

MAINTENANCE PROCEDURES

None.

34-27-00 INERTIAL REFERENCE SYSTEM (IRS)

Placard IRS Mode Selector Unit Panel "IRS INOP".

OPERATIONAL PROCEDURES

None.

MAINTENANCE PROCEDURES

None.



34-27-05 IRS MSU ANNUNCIATORS LIGHTS

Placard IRS Mode Selector Unit Panel "ALIGN BUTTON INOP" or "FAULT BUTTON INOP" or "ON BATT BUTTON INOP" or "NO AIR BUTTON INOP" or "NAV RDY BUTTON INOP" or "BATT FAIL BUTTON INOP".

OPERATIONAL PROCEDURES

NAV mode check:

For airplane with dual IRS:

Initialization phase:

- IRS MSU knob NAV
- "IRS ALIGN" EICAS message Displayed
- "ATT" and "HDG" flag on PFD Displayed

After initialization phase is finished, check:

- "IRS ALIGN" EICAS message Extinguished
- "ATT" and "HDG" flag on PFD Extinguished

If check is successful, IRS is available for NAV mode.

For airplanes with single IRS:

Initialization phase:

- IRS MSU knob NAV
- "ATT" and "HDG" flag on HUD Displayed

After initialization phase is finished, check:

- "ATT" and "HDG" flag on HUD Extinguished

If check is successful, IRS is available for NAV mode.

IRS battery power supply check:

For airplanes with single or dual IRS:

- BATT 1 and BATT 2 knob AUTO
- Backup Battery Button CHECKED
PUSHED IN
- IRS Circuit Breaker PULL
- IRS CHECK
AVAILABLE

If IRS remains available after check above, it means that only "BATT FAIL" annunciator light is inoperative and IRS system operates normally.

Before dispatch, turn back to normal configuration:

- BATT 1 and BATT 2 knob AUTO
- IRS Circuit Breaker PUSH

IRS system is available to dispatch.

1-09-34	Page 4	Code 02
---------	-----------	------------

MAINTENANCE PROCEDURES

None.

34-31-00 RADIO ALTIMETER SYSTEM

Placard in Clear View of the Pilots or PFD Bezel "RA* or RA 1 or RA 2 or RA 1 AND RA 2 INOP".

OPERATIONAL PROCEDURES

Equipment affected by Radio Altimeter deactivation:

Pre-Mod SB145-34-0083:

RA* or RA 1 circuit breaker pulled:

- GPWS/EGPWS inoperative.
- WINDSHEAR inoperative.
- TCAS inoperative (For airplanes equipped with dual RA, the TCAS will be inoperative only if RA 1 and RA 2 are lost simultaneously).

RA 2 circuit breaker pulled:

- None.

Post-Mod SB145-34-0083:

RA* or RA 1 or RA 2 circuit breaker pulled:

- GPWS/EGPWS inoperative.
- WINDSHEAR inoperative.
- TCAS (For airplanes equipped with dual RA, the TCAS will be inoperative only if RA 1 and RA 2 are lost simultaneously).

MAINTENANCE PROCEDURES

May be flight crewmember accomplished.

Radio Altimeter deactivated:

Pull and safety affected Radio Altimeter circuit breaker:

RADIO ALTIMETER	CIRCUIT BREAKER
RA*	D14
RA 1	D14
RA 2	D21

* Applicable for airplanes equipped with only one Radio Altimeter.



34-31-01 ALTITUDE ALERTER FUNCTION

Placard on PFD Bezel "ALTITUDE ALERT INOP".

OPERATIONAL PROCEDURES

None.

NOTE: Normal altitude call out and visual alerts (change in colors provided above the altitude display on both PFD's) shall be used.

MAINTENANCE PROCEDURES

None.

34-31-02 ALTITUDE PRESELECT FUNCTION

Placard adjacent to ASEL knob on Flight Guidance Controller "ASEL INOP".

OPERATIONAL PROCEDURES

General Information:

- With altitude preselect function inoperative, the altitude preselect display on PFD may present dashes, zero or a fixed altitude value.
- Pilots should use the Altitude Hold mode to capture the desired altitude during climb and descent operations. Normal altitude callout procedure should be used.
- Flight Level Change mode must not be used and should be considered inoperative.
- Altitude alerter annunciation or altitude preselected information must be disregarded by the crewmembers.
- RVSM operation is not allowed.
- Go-Around Buttons must not be used and should be considered inoperative.

NOTE: - If dashes are presented on the altitude preselect display on PFD, it will be understood as zero-feet altitude by the Flight Director.

- Pilots must be warned that, if a fixed altitude value is presented on the altitude preselect display on the PFD, the airplane may capture this altitude when reaching it.

1-09-34	Page 6	Code 02
---------	-----------	------------

Altitude Hold Mode check:

With airplane on the ground and energized:

Flight Director ON

HDG mode SELECT

 Check HDG and PIT label annunciated on the PFD.

SPD mode SELECT

 Check command bar moving on the PFD.

ALT mode SELECT

 Check command bar capturing present altitude and the ALT green label presented on the PFD.

Takeoff procedure:

Since Go-Around buttons cannot be used, pilots must perform the Takeoff Submode manually using the Touch Control Steering Button (TCS).

Selecting just a lateral mode (HDG or NAV) will activate the basic vertical mode (PIT). At rotation, keep the TCS button pressed to command a pitch attitude of 14° (for flaps at 9°), 13° (for flaps at 18°), or 12° (for flaps at 22°). Once the Pitch value is reached, the TCS button must be released and the Flight Director will maintain the set pitch until a new vertical mode is selected.

Go-Around procedure:

During Go-Around procedure autopilot must be disengaged and go-around buttons must not be used. Flight Director must be reverted to basic mode (ROL and PIT) and pilots should perform the Go-Around mode manually using the Touch Control Steering Button (TCS).

While keeping the TCS button pressed, pilots should command a pitch attitude to allow a climbing turn with airspeed around 1.23 Vs. Once a positive rate of climb has been achieved, pilots should set a pitch of 10° nose up and release the TCS button. This constant pitch attitude must be maintained for at least 20 seconds. After that, the IAS Speed Hold mode must be selected following the go-around speed preselect on the airspeed bug with limitation at 1.23 Vs.

MAINTENANCE PROCEDURES

None.



34-32-00 VOR/ILS SYSTEMS

Placard in Clear View of the Pilots or PFD Bezel "VOR/ILS INOP", "ILS INOP" or "MARKER BEACON INOP".

OPERATIONAL PROCEDURES

None.

MAINTENANCE PROCEDURES

None.

34-41-00 ENHANCED GROUND PROXIMITY WARNING SYSTEM (EGPWS)

Placard GPWS Lights "GPWS INOP".

OPERATIONAL PROCEDURES

Operators should develop and use alternate procedures in order to increase flight crew awareness of airplane configuration, altitude and flight path. This may include use of all airplane systems available, as autopilot, ILS, FMS, etc. and flight crew review of Minimum Enroute Altitudes (MEA) and altitude callouts.

NOTE: The Principal Operations Inspector (POI) shall ensure an operator's alternate procedures are comprehensive and appropriate for dispatch with Windshear modes or functions of TAWS inoperative. An operator's alternate procedures and preflight briefings must include and emphasize:

- Use of established procedures to assess and minimize the probability of encountering windshear during takeoff/ departure and approach/landing.
- Use of established procedures (windshear escape/recovery maneuvers) to minimize the effects of unexpected windshear encounter during takeoff/departure and approach/landing.

MAINTENANCE PROCEDURES

None.

1-09-34	Page 8	Code 02
---------	-----------	------------

34-41-02 STEEP APPROACH FUNCTION

Placard PFD Bezel "STEEP APPROACH INOP".

OPERATIONAL PROCEDURES

None.

MAINTENANCE PROCEDURES

Steep Approach deactivation:

May be flight crewmember accomplished. Pull and safety the STEEP APPROACH (D1) circuit breaker on the Circuit Breaker panel.

NOTE: Some airplanes may present a different circuit breaker positioning configuration. Specific configuration may be found in the Aircraft Maintenance Manual (AMM).

34-42-00 WEATHER RADAR SYSTEM

Placard Weather Radar Control Panel "INOP" or "STABILIZATION INOP".

OPERATIONAL PROCEDURES

None.

MAINTENANCE PROCEDURES

Refer to RAMP MANUAL 34-42-00 for antenna sweep check.

34-42-01 STORMSCOPE

Placard Weather Radar Control Panel "TURBULENCE DET INOP".

OPERATIONAL PROCEDURES

None.

MAINTENANCE PROCEDURES

None.

34-43-00 TRAFFIC ALERT AND COLLISION AVOIDANCE SYSTEM

Placard RMU or MFD Bezel Display or Panel "TCAS INOP".

OPERATIONAL PROCEDURES

RA or TA visual and audio function check:

Perform TCAS System test to ensure that RA or TA display and audio functions are operative.

MAINTENANCE PROCEDURES

Traffic Alert and Collision Avoidance System deactivation:

May be flight crewmember accomplished. Pull and safety affected TCAS circuit breaker:

MODEL	CIRCUIT BREAKER
TCAS I	J6
TCAS II	J6
TCAS 2000	D3

NOTE: It is not recommended setting the ATC ON because this mode does not transmit the altitude reporting.

34-51-00 DISTANCE MEASURING EQUIPMENT (DME) SYSTEMS

Placard PFD Bezel "DME INOP".

OPERATIONAL PROCEDURES

None.

MAINTENANCE PROCEDURES

None.

34-52-00 ATC TRANSPONDERS AND AUTOMATIC ALTITUDE REPORTING SYSTEMS

Placard RMU Panel "XPDR INOP".

OPERATIONAL PROCEDURES

None.

MAINTENANCE PROCEDURES

None.

34-53-00 ADF SYSTEM

Placard RMU Bezel "ADF INOP".

OPERATIONAL PROCEDURES

None.

MAINTENANCE PROCEDURES

None.

34-54-00 XM WEATHER SYSTEM

Placard Weather Radio System "INOP".

OPERATIONAL PROCEDURES

None.

MAINTENANCE PROCEDURES

None.



34-56-00 GLOBAL POSITIONING SYSTEM

Placard GPS Panel "INOP".

OPERATIONAL PROCEDURES

According to the MMEL remarks.

NOTE: In case of GPS inoperative, terrain awareness alerting and display functionality must be manually inhibited. For dual GPS configuration, terrain awareness alerting and display functionality must be manually inhibited only when both GPS are inoperative.

MAINTENANCE PROCEDURES

None.

34-60-00 FLIGHT MANAGEMENT SYSTEM

Placard FMS Panel "INOP".

OPERATIONAL PROCEDURES

According to the MMEL remarks.

MAINTENANCE PROCEDURES

None.

NOTE: – The AH-900 AHRS complete alignment requires a valid input of the airplane's present position from the FMS or through the MDF 1. The present position input through MFD 1 is possible only if the IM-600 has been properly configured (airplanes equipped with EICAS 18 and on).

– Airplanes equipped with EGPWS and operating without FMS will lose the terrain clearance floor mode. A TERRAIN INOP message will be presented on the EICAS.

1-09-34	Page 12	Code 02
---------	------------	------------

ATA CHAPTER 35 OXYGEN

35-11-00 OXYGEN PRESSURE INDICATION SYSTEMS

Placard MFD Bezel "OXY PRESS IND INOP".

OPERATIONAL PROCEDURES

If MFD oxygen pressure indicator inoperative:

Check the gage reading on the oxygen service panel. It must be at or above the minimum required for dispatch (refer to the AOM - Section 2-16-30 - Minimum Oxygen Pressure for Dispatch).

If oxygen service panel indicator inoperative:

Check the digital reading on the MFD. It must be at or above the minimum required for dispatch (refer to the AOM - Section 2-16-30 - Minimum Oxygen Pressure for Dispatch).

MAINTENANCE PROCEDURES

None.

35-11-03 OXYGEN-CYLINDER PRESSURE RELIEF DISC (GREEN DISC)

Placard as appropriate.

OPERATIONAL PROCEDURES

None.

MAINTENANCE PROCEDURES

None.



35-20-00 PASSENGER OXYGEN SYSTEM

Placard Passenger Oxygen Panel "PAX OXY DEPLOY INOP" or "PAX OXY INOP".

OPERATIONAL PROCEDURES

If automatic deployment is inoperative and it is necessary to deploy passenger oxygen masks, position the Passenger Oxygen Selector knob to MAN.

OR

According to the MMEL remarks.

MAINTENANCE PROCEDURES

Perform TASK 35-20-00-700-801-A (AMM) for manual deployment system operational check.

OR

According to the MMEL remarks.

35-20-05 PASSENGER OXYGEN SYSTEM DOOR - MANUAL OPENING TOOL

OPERATIONAL PROCEDURES

According to MMEL remarks.

MAINTENANCE PROCEDURES

None.

1-09-35	Page 2	Code 02
---------	-----------	------------

35-30-01 PORTABLE OXYGEN UNITS (BOTTLE AND MASK)

Placard associated Bottle and Mask "INOP".

OPERATIONAL PROCEDURES

None.

MAINTENANCE PROCEDURES

May be flight crewmember accomplished.

Inoperative bottles and masks are placarded inoperative, removed from the installed location and placed out of sight so they cannot be mistaken for a functional unit.

Inoperative bottles and masks are replaced, serviced or removed at the next base maintenance facility.

35-30-03 PROTECTIVE BREATHING EQUIPMENT (PBE)

Placard on the affected equipment storage compartment "REMOVED".

OPERATIONAL PROCEDURES

None.

MAINTENANCE PROCEDURES

None.

**DISPATCH
DEVIATIONS
PROCEDURES
MANUAL**



INTENTIONALLY BLANK

1-09-35	Page 4	Code 02
---------	-----------	------------

REVISION 9

DDPM-145/1116

ATA CHAPTER 36 PNEUMATIC

36-11-05 ENGINE BLEED SYSTEMS

Placard the affected Bleed Air Button "INOP".

OPERATIONAL PROCEDURES

When the Left Engine Bleed Shutoff Valve is inoperative and the Right Engine Bleed Shutoff Valve and the APU Bleed Shutoff Valve are operating normally and supplying bleed air, flight should be conducted at or below FL 370.

When the Left Engine Bleed Shutoff Valve and the APU Bleed Shutoff Valve are inoperative and the Right Engine Bleed Shutoff Valve is operating normally and supplying bleed air, flight should be conducted at or below FL 250.

When the Right Engine Bleed Shutoff Valve is inoperative and the Left Engine Bleed Shutoff Valve is operating normally and supplying bleed air, flight should be conducted at or below FL 250.

When Both Engine Bleed Shutoff Valves are inoperative and the APU Bleed Shutoff Valve is operating normally and supplying bleed air, flight should be conducted at or below 18000 ft.

When Both Engine Bleed Shutoff Valves and the APU bleed Shutoff Valve are inoperative, flight should be conducted at or below 10000 ft. Refer to Item 21-31-03 for unpressurized configuration flight. On the ground, ambient temperature must be below ISA + 21°C.

MAINTENANCE PROCEDURES

NOTE: For MMEL dispatch purposes, the Engine Bleed System is comprised of: Engine Bleed Shutoff Valve (EBV) or Pressure Regulator Shutoff Valve (P-RSOV), Fan Air Valve, Fan Air Thermostat, Pre-Cooler and Bleed Temperature Sensors, Differential Pressure Switch, High Stage Valve, High Stage Pressure Switch and Bleed Air Check Valve.

Engine Bleed Shutoff Valve secured closed:

- Gain access to the affected valve (AMM - Chapter 36).
- Disconnect, insulate and stow the electrical connector.
- Remove the locking screw from the actuator housing. It has a retaining cable.
- Turn the valve to the closed position. The locking crank has a hex head so you can put a wrench on it to turn the valve.
- Install the locking screw in the hole in the actuator housing that is nearest to the locking crank.

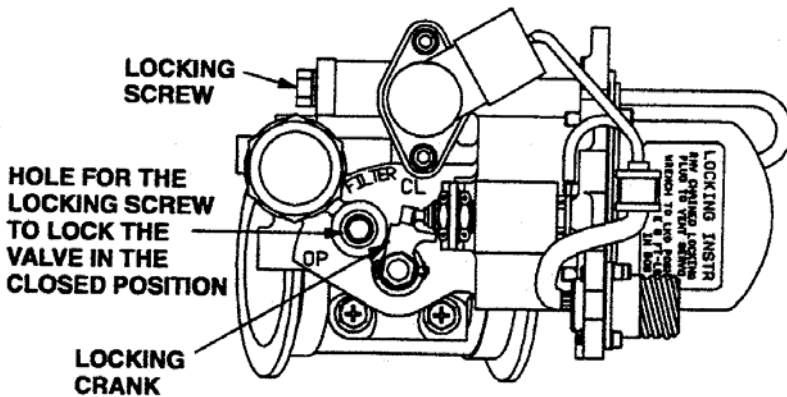

ENGINE BLEED SHUTOFF VALVE

1-09-36	Page 2	Code 02
---------	-----------	------------

REVISION 12

Engine Bleed Pressure Regulator Shutoff Valve secured closed:

- Remove the following access panels: 414DB (LH pylon) or 424DB (RH pylon).
- Verify that the pneumatic system is de-pressurized and that the solenoid is de-energized.
- Loosen the position indicator lock screw.
- Slide the lock into the recess of the cover plate. A rotation of the screw may be necessary to center the lock in the recess of the cover plate.
- Torque the position indicator lock screw to 11 to 13 lb-in.

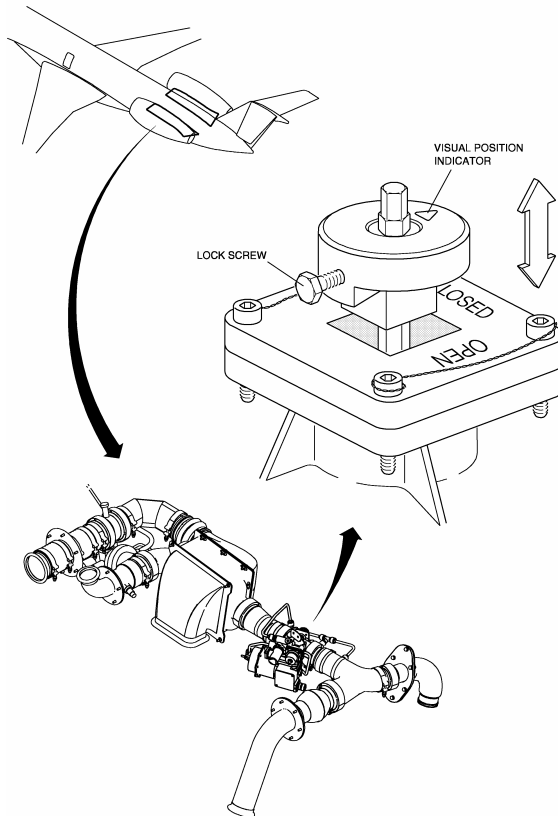

145AOM1090007.MCE

ENGINE BLEED PRESSURE REGULATOR SHUTOFF VALVE



36-11-10 AIR CONDITIONING PANEL AIR BUTTON RED LEAK INDICATION

Placard affected Bleed Air Button "LEAK INDICATION INOP".

OPERATIONAL PROCEDURES

None.

MAINTENANCE PROCEDURES

Perform TASK 36-20-02-700-802-A (AMM) for EICAS indication for thermal switch operation check.

1-09-36	Page 4	Code 02
---------	-----------	------------

REVISION 9

36-12-01 APU BLEED SYSTEM

Placard APU Bleed Button "INOP".

OPERATIONAL PROCEDURES

None.

NOTE: In case of APU bleed system deactivated, a ground pneumatic unit is required for engine start. Refer to item 49-00-00 (operational procedure).

MAINTENANCE PROCEDURES

APU Bleed Shutoff Valve secured closed:

Perform TASK 36-12-01-040-801-A (AMM) for APU T-62T-40 C11 or TASK 36-12-03-040-801-A (AMM) for APU T-62T-40 C14.



36-20-00 BLD APU LEAK WARNING MESSAGE

Placard EICAS Bezel "BLD APU LEAK MESSAGE INOP".

OPERATIONAL PROCEDURES

None.

MAINTENANCE PROCEDURES

None.

1-09-36	Page 6	Code 02
---------	-----------	------------

REVISION 9

ATA CHAPTER 38 WATER/WASTE

38-10-00 WATER SYSTEMS

Placard External Potable Water Service Door "DO NOT SERVICE". Register as appropriate for maintenance actions.

OPERATIONAL PROCEDURES

None.

MAINTENANCE PROCEDURES

- Deactivate or isolate the associated inoperative components.
- If system is leaking, it must be drained. Ground service must be contact to drain system.
- If tank can not be drained, accomplish AMM TASK 38-10-05-790-801-A for the tank valve leakage test.

38-30-00 LAVATORY WASTE SYSTEMS (INCLUDING WHEELCHAIR ACCESSIBLE LAVATORIES)

Placard Lavatory Door "LAVATORY INOPERATIVE". Register as appropriate for maintenance actions.

OPERATIONAL PROCEDURES

- Inspections of the lavatory by crewmembers.
- Flight attendant must be briefed that the lavatory is locked and may not be used.
- Advise Ground Service Personnel **not** to service Lavatory waste system.

MAINTENANCE PROCEDURES

- Deactivate or isolate the associated inoperative components.
- If system is leaking, ground service must be contact to drain system. In case of toilet overservicing, perform AMM TASK 05-50-12-100-801-A (Cleaning Procedure) prior to next flight and AMM TASK 05-50-12-200-801-A (Complete Cleaning Procedure/Check) within next 10 consecutive days.
- May be flight crewmember accomplished: Lock lavatory door and install "LAVATORY INOPERATIVE" placard on lavatory door.

DDPM-145/1116

**DISPATCH
DEVIATIONS
PROCEDURES
MANUAL**



INTENTIONALLY BLANK

1-09-38	Page 2	Code 02
---------	-----------	------------

REVISION 9

DDPM-145/1116



**DISPATCH
DEVIATIONS
PROCEDURES
MANUAL**

ATA CHAPTER 45
CENTRAL
MAINTENANCE
COMPUTER

ATA CHAPTER 45 CENTRAL MAINTENANCE COMPUTER

45-45-01 CONTROL MAINTENANCE COMPUTER (CMC)

Register as appropriate for maintenance personnel actions.

OPERATIONAL PROCEDURES

None.

MAINTENANCE PROCEDURES

None.

DDPM-145/1116

REVISION 9

1-09-45	Page 1	Code 02
---------	-----------	------------

**DISPATCH
DEVIATIONS
PROCEDURES
MANUAL**



INTENTIONALLY BLANK

1-09-45	Page 2	Code 02
---------	-----------	------------

REVISION 9

DDPM-145/1116



**DISPATCH
DEVIATIONS
PROCEDURES
MANUAL**

ATA CHAPTER 46
INFORMATION SYSTEMS

ATA CHAPTER 46 INFORMATION SYSTEMS

46-20-01 ELETRONIC FLIGHT BAG SYSTEMS (EFB)

Placard as appropriate.

OPERATIONAL PROCEDURES

As required to meet MMEL remarks.

MAINTENANCE PROCEDURES

Perform TASK 34-63-01-000-801-A (AMM) for EFB removal.

DDPM-145/1116

REVISION 9

1-09-46	Page 1	Code 02
---------	-----------	------------

**DISPATCH
DEVIATIONS
PROCEDURES
MANUAL**



INTENTIONALLY BLANK

1-09-46	Page 2	Code 02
---------	-----------	------------

REVISION 9

DDPM-145/1116

ATA CHAPTER 49 AIRBORNE AUXILIARY POWER

49-00-00 AUXILIARY POWER UNIT (APU)

Placard APU Control Panel "INOP".

OPERATIONAL PROCEDURES

A Pneumatic Start Unit is required for engine start when APU is inoperative. Refer to TASK 20-40-03-860-801-A (AMM) to connect the Pneumatic Start Unit.

If no Pneumatic Start Unit is available, at least one engine should be kept running during turn-around (refer to AOM Section 1-12-25 Refueling with an Engine Running and Deplaning or Boarding with One Engine Running procedures).

MAINTENANCE PROCEDURES

May be flight crewmember accomplished. Pull and safety the APU CONTROL circuit breakers, (C30) on the Circuit Breaker panel and the (E6) on the Left DC distribution box.

49-70-01 APU OIL LO PRESS CAUTION MESSAGE

Placard APU Control Panel "USE ONLY ON GROUND".
Placard EICAS Bezel "APU OIL LO PRESS MESSAGE INOP".

OPERATIONAL PROCEDURES

None.

MAINTENANCE PROCEDURES

None.

49-70-02 APU OIL HI TEMP CAUTION MESSAGE

Placard APU Control Panel "USE ONLY ON GROUND".
Placard EICAS Bezel "APU OIL HI TEMP MESSAGE INOP".

OPERATIONAL PROCEDURES

None.

MAINTENANCE PROCEDURES

None.

49-70-03 APU FAIL CAUTION MESSAGE

Placard APU Control Panel "USE ONLY ON GROUND".
Placard EICAS Bezel "APU FAIL MESSAGE INOP".

OPERATIONAL PROCEDURES

None.

MAINTENANCE PROCEDURES

None.

1-09-49	Page 2	Code 02
---------	-----------	------------

49-74-01 APU HOURMETER FUNCTION

Register in the appropriate document for the necessary actions.

OPERATIONAL PROCEDURES

None.

MAINTENANCE PROCEDURES

The operator shall develop appropriate procedures according to its airplane utilization to control APU operating hours.

**DISPATCH
DEVIATIONS
PROCEDURES
MANUAL**



INTENTIONALLY BLANK

1-09-49	Page 4	Code 02
---------	-----------	------------

REVISION 9

DDPM-145/1116

ATA CHAPTER 52 DOORS

52-12-00 MAIN DOOR HYDRAULIC ACTUATION SYSTEM

Placard on Door Panel (Entrance and Exterior) "DOOR ACTUATION INOP".

OPERATIONAL PROCEDURES

None.

MAINTENANCE PROCEDURES

Damper Function checking:

May be flight crewmember accomplished. Lift the door manually up to its mid closed position, and then let the door to come down. Check that door moves down slowly, with damping.

NOTE: Care should be taken to avoid that the door coming down without damping.

52-51-00 C&D AEROSPACE FLIGHT DECK SECURITY DOOR

Placard Door "INOP".

OPERATIONAL PROCEDURES

None.

MAINTENANCE PROCEDURES

None.

52-70-00 DOOR WARNING SYSTEM (DOOR POSITION INDICATION ON MFD AND EICAS)

Placard MFD and EICAS Bezel "AFFECTED DOOR WARNING IND INOP".

OPERATIONAL PROCEDURES

Carefully check all doors closed and latched before each departure. Main and service door internal check must be done by using a flashlight to confirm that all the red marks of each door are aligned (see figures).

NOTE: This procedure requires the usage of a flashlight to help visualizing the red marks alignment precisely.

MAINTENANCE PROCEDURES

May be flight crewmember accomplished. Carefully check all doors closed and latched before each departure. Main, service and baggage doors must be checked aligned with the fuselage and the handles must be stowed.

In case of nuisance message being triggered:

- Perform AMM TASK 52-71-01-000-801-A for forward electronic compartment access hatch, at operators discretion.
- Perform AMM TASK 52-72-01-000-801-A for cockpit underfloor access hatch, at operators discretion.
- Perform AMM TASK 52-73-01-000-801-A for main door, at operators discretion.
- Perform AMM TASK 52-74-01-000-801-A for service door, at operators discretion.
- Perform AMM TASK 52-75-01-000-801-A for emergency access hatches, at operators discretion.
- Perform AMM TASK 52-76-01-000-801-A for cargo door, at operators discretion.
- Perform AMM TASK 52-77-01-000-801-A for rear electronic compartment access hatch, at operators discretion.
- Perform AMM TASK 52-78-01-000-801-A for fueling door, at operators discretion.

1-09-52	Page 2	Code 02
---------	-----------	------------

REVISION 12

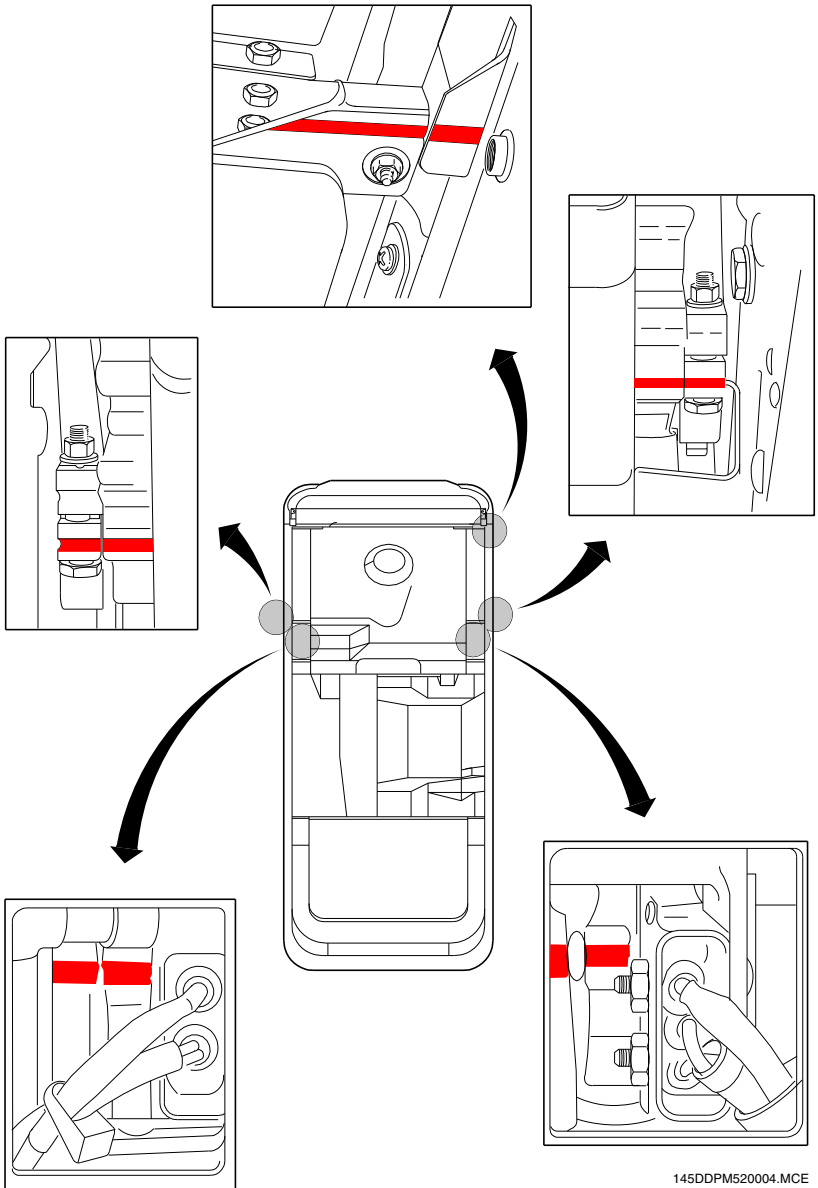

145DDPM520004.MCE

SIDE-HINGED MAIN DOOR RED MARKS

DDPM-145/1116

REVISION 9

1-09-52	Page 3	Code 02
---------	-----------	------------

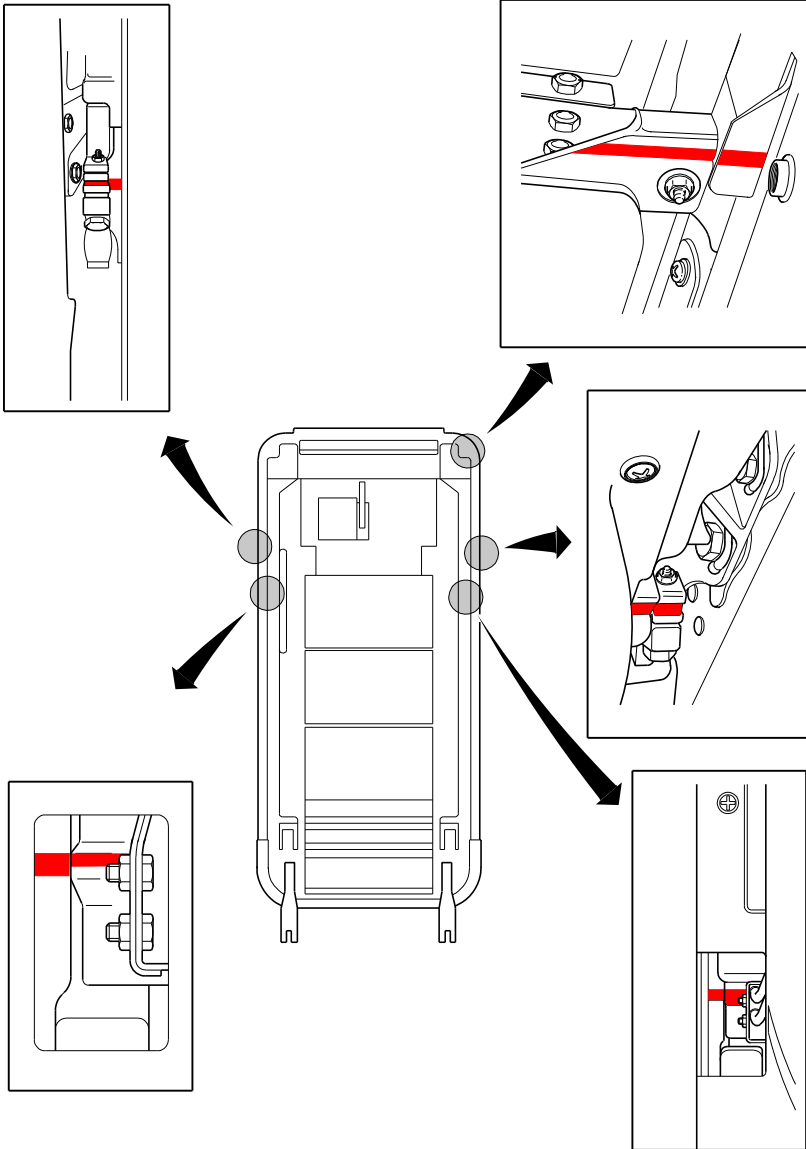

145DDPM520005.MCE

AIRSTAIRS MAIN DOOR RED MARKS

NOTE: Some airplanes may have only the upper right red mark.

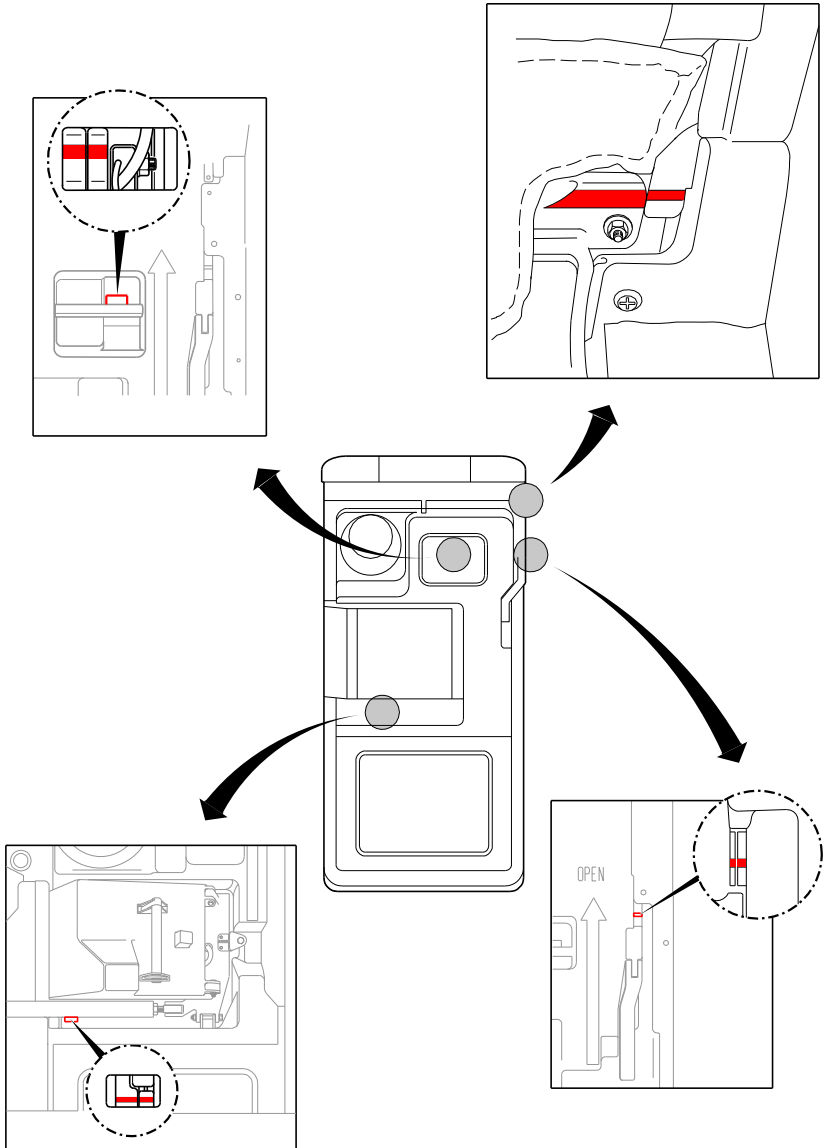

145DDPM520006.MCE

SERVICE DOOR RED MARKS

**DISPATCH
DEVIATIONS
PROCEDURES
MANUAL**



INTENTIONALLY BLANK

1-09-52	Page 6	Code 02
---------	-----------	------------

REVISION 9

DDPM-145/1116



**DISPATCH
DEVIATIONS
PROCEDURES
MANUAL**

ATA CHAPTER 56
WINDOWS

ATA CHAPTER 56 WINDOWS

56-10-01 DELETED

DDPM-145/1116

REVISION 9

1-09-56	Page 1	Code 02
---------	-----------	------------

**DISPATCH
DEVIATIONS
PROCEDURES
MANUAL**



INTENTIONALLY BLANK

1-09-56	Page 2	Code 02
---------	-----------	------------

REVISION 9

DDPM-145/1116

ATA CHAPTER 73 ENGINE FUEL AND CONTROL

73-22-01 ENGINE FULL AUTHORITY DIGITAL ELECTRONIC CONTROL (FADEC) SYSTEM

Placard Power Plant Control Panel "FADEC XX DEFERRED BY MEL/TLD".

OPERATIONAL PROCEDURES

None.

MAINTENANCE PROCEDURES

None.



73-22-02 AUTOMATIC TAKEOFF THRUST CONTROL SYSTEM (ATTCS) (AIRPLANES EQUIPPED WITH A, A1/1, A1 AND A3 ENGINES ONLY)

Placard near Thrust Rating Mode Buttons "ATTCS INOP".

OPERATIONAL PROCEDURES

Select T/O-1 thrust mode using Takeoff Data Setting procedure prior to takeoff. Refer to AOM - Section 2-10.

MAINTENANCE PROCEDURES

None.

73-32-01 ENGINE FUEL TEMPERATURE SENSORS

Placard EICAS Bezel "E1 (or 2) LO TEMP MESSAGE INOP".

OPERATIONAL PROCEDURES

Ensure that icing inhibitor is added to the fuel. If an icing inhibitor has not been added, refer to MFD fuel page and ensure temperature of fuel in the tank remains above 4°C throughout the flight.

MAINTENANCE PROCEDURES

None.

1-09-73	Page 2	Code 02
---------	-----------	------------

73-33-01 E1 (2) FUEL IMP BYP ADVISORY MESSAGES

Placard EICAS Bezel "E1 (or 2) FUEL IMP BYP MESSAGE INOP".

OPERATIONAL PROCEDURES

None.

MAINTENANCE PROCEDURES

NOTE: The engine fuel temperature sensors must not be dispatched under MMEL 73-32-01 in case of E1 (2) FUEL IMP BYP messages inoperative.

- Energize the airplane with a DC Power Supply (TASK 20-40-01-860-801-A – AMM).
- Pull the START 1 and START 2 circuit breakers (B12 and B23 respectively) and attach DO-NOT-CLOSE tags to them.
- Open the associated engine lower cowling door (TASK 71-12-01-000-801-A – AMM).
- Use the following check procedures as a troubleshooting reference:

Visual indicators (pop-up buttons) check:

- Check that both the electrical/mechanical impending-bypass indicator and the mechanical actual-bypass indicator (See Figure) have their respective pop-up buttons not protruded.

Electrical/mechanical impending-bypass indicator (switch) check:

- Check that the resistance between pins B and C in the electrical/mechanical impending-bypass indicator is not greater than 10 ohms.
- Check that the resistance between the indicator shell and pins B and C, one at a time, is not lower than 1000 ohms.

Electrical connector (wiring) check:

- Disconnect the electrical connector from the electrical/mechanical impending-bypass indicator (See Figure) and wait at least 10 seconds.
- Check that EICAS advisory message E1 (2) FUEL IMP BYP is displayed.
- Connect the electrical connector to the electrical/mechanical impending-bypass indicator.
- Check that EICAS advisory message E1 (2) FUEL IMP BYP goes out of view.

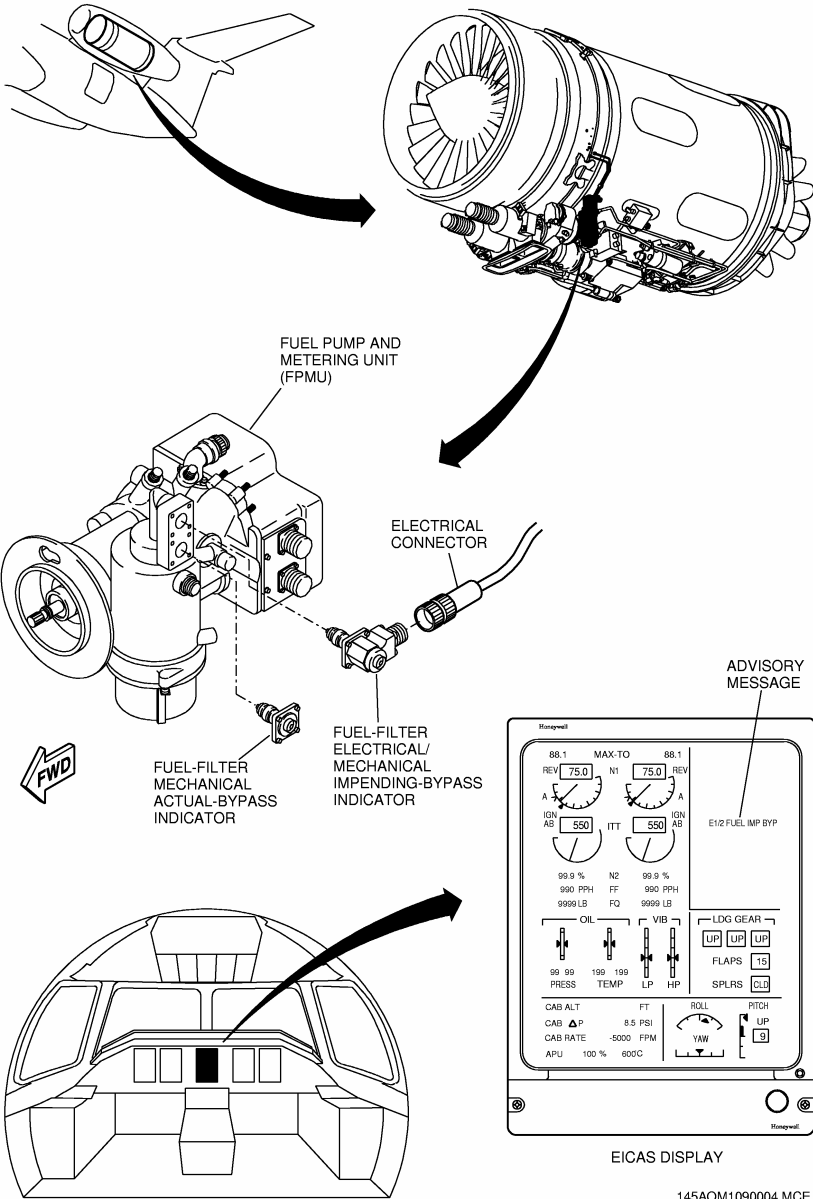

FUEL FILTER BYPASS INDICATORS

After checking:

- Close the engine lower cowling door (TASK 71-12-01-400-801-A – AMM).
- Push in the START 1 and START 2 circuit breakers (B12 and B23 respectively) back and remove the DO-NOT-CLOSE tags from them.
- Remove the DC Power Supply (TASK 20-40-01-860-801-A – AMM).

73-33-02 FUEL FILTERS

Register as appropriate for maintenance actions.

OPERATIONAL PROCEDURES

None.

MAINTENANCE PROCEDURES

Associated fuel-filter mechanical actual-bypass indicator is checked not extended before each flight.

73-40-03 FUEL FLOW INDICATIONS

Placard EICAS Bezel "FUEL FLOW INOP".

OPERATIONAL PROCEDURES

NOTE: Abort engine start immediately when:

- Only on ground, no light-up in 20 seconds after the engine start command.

Monitor remaining engine parameters within normal values.

MAINTENANCE PROCEDURES

None.

**DISPATCH
DEVIATIONS
PROCEDURES
MANUAL**



INTENTIONALLY BLANK

1-09-73	Page 6	Code 02
---------	-----------	------------

REVISION 9

DDPM-145/1116

ATA CHAPTER 74 IGNITION

74-20-00 IGNITION SYSTEM CHANNELS

Placard Power Plant Control Panel on overhead panel, close to the Ignition Selector Knob of the affected engine "ONE CHANNEL INOP".

OPERATIONAL PROCEDURES

- Before starting the affected engine, select Ignition Selector Knob ON.
- Upon reaching 14% N2 during start, check green label IGN AB on EICAS.
- After normal engine start cycle completed, check steady engine parameters.
- Select Ignition Selector Knob AUTO (blank indication on EICAS).

MAINTENANCE PROCEDURES

None.

**DISPATCH
DEVIATIONS
PROCEDURES
MANUAL**



INTENTIONALLY BLANK

1-09-74	Page 2	Code 02
---------	-----------	------------

REVISION 9

DDPM-145/1116

ATA CHAPTER 76 ENGINE CONTROLS

76-12-00 ENGINE TAKEOFF DATA SETTING KNOB SPRING

Placard Overhead Panel "ENGINE TDS KNOB INOP".

OPERATIONAL PROCEDURES

Select TOTEMP and takeoff data through the inoperative knob, press STORE and check MFD takeoff parameters before takeoff.

MAINTENANCE PROCEDURES

None.

**DISPATCH
DEVIATIONS
PROCEDURES
MANUAL**



INTENTIONALLY BLANK

1-09-76	Page 2	Code 02
---------	-----------	------------

REVISION 10

DDPM-145/1116

ATA CHAPTER 77 ENGINE INDICATING

77-41-02 HP VIBRATION INDICATION

Placard EICAS Bezel "HP VIB INOP".

OPERATIONAL PROCEDURES

None.

MAINTENANCE PROCEDURES

None.

**DISPATCH
DEVIATIONS
PROCEDURES
MANUAL**



INTENTIONALLY BLANK

1-09-77	Page 2	Code 02
---------	-----------	------------

REVISION 9

DDPM-145/1116

ATA CHAPTER 78 ENGINE EXHAUST

78-30-00 THRUST REVERSERS

Placard Control Pedestal "THRUST REVERSER INOP".

OPERATIONAL PROCEDURES

When operating with one thrust reverser secured stowed, the FADEC of the operative side will only command reverse thrust if the associated Thrust Lever is requesting reverse thrust and the Thrust Lever of the affected side is set to idle.

MAINTENANCE PROCEDURES

Perform TASK 78-31-01-980-801-A (AMM) for the affected thrust reverser stowage.

In case of thrust reverser hydraulic system leakage, perform TASK 78-31-01-980-803-A (AMM) before performing TASK 78-31-01-980-801-A (AMM).

78-34-00 ENG1 (2) REV DISAGREE MESSAGES

OPERATIONAL PROCEDURES

When operating with one thrust reverser secured stowed, the FADEC of the operative side will only command reverse thrust if the associated Thrust Lever is requesting reverse thrust and the Thrust Lever of the affected side is set to idle.

MAINTENANCE PROCEDURES

Perform TASK 78-31-01-980-801-A (AMM) for thrust reverser stowage.

78-34-05 IDLE STOP (SOLENOID)

Placard Control Pedestal "THRUST REVERSER INOP".

OPERATIONAL PROCEDURES

When operating with one thrust reverser secured stowed, the FADEC of the operative side will only command reverse thrust if the associated Thrust Lever is requesting reverse thrust and the Thrust Lever of the affected side is set to idle.

NOTE: Never set thrust levers below idle in flight.

MAINTENANCE PROCEDURES

Perform TASK 78-31-01-980-801-A (AMM) for the affected thrust reverser stowage.

In case of thrust reverser hydraulic system leakage, perform TASK 78-31-01-980-803-A (AMM) before performing TASK 78-31-01-980-801-A (AMM).

1-09-78	Page 2	Code 02
---------	-----------	------------

ATA CHAPTER 79 ENGINE OIL

79-32-01 LOW OIL PRESSURE SWITCHES

Placard EICAS Bezel "E1 (or 2) OIL LOW PRESS MESSAGE INOP".

OPERATIONAL PROCEDURES

None.

MAINTENANCE PROCEDURES

Perform TASK 12-12-01-600-801-A (AMM) for oil quantity servicing.

79-33-01 OIL LEVEL INDICATION SYSTEMS

Placard MFD Bezel "OIL1 (or 2) IND INOP".

OPERATIONAL PROCEDURES

None.

MAINTENANCE PROCEDURES

Perform TASK 12-12-01-600-801-A (AMM) for oil quantity servicing.

79-34-01 OIL PARTICLE SENSORS

Register as appropriate for maintenance actions.

OPERATIONAL PROCEDURES

None.

MAINTENANCE PROCEDURES

Perform the visual check on the affected oil tank magnetic plug. Refer to Rolls Royce MM TASK 79-30-00-200-801.



79-35-01 E1 (2) OIL IMP BYP MESSAGES

Register as appropriate for maintenance actions.

OPERATIONAL PROCEDURES

None.

MAINTENANCE PROCEDURES

Open the affected engine lower cowling and verify the visual indicator inside housing.

Perform TASK 45-45-00-970-801-A (AMM) for the CMC downloading with the MFD maintenance page.

79-35-02 OIL FILTERS

Register as appropriate for maintenance actions.

OPERATIONAL PROCEDURES

None.

MAINTENANCE PROCEDURES

Perform TASK 79-30-00-200-802 (ROLLS ROYCE AE3007A Series Maintenance).

1-09-79	Page 2	Code 02
---------	-----------	------------

ATA CHAPTER 80 STARTING

80-00-00 ENGINE START/STOP SWITCH PROTECTION GUARDS

Placard Powerplant Control Panel "PROTECTION GUARD INOP".

OPERATIONAL PROCEDURES

None.

MAINTENANCE PROCEDURES

None.



80-10-02 STARTER CONTROL VALVES

Placard EICAS Bezel or Powerplant Control Panel "STARTER CONTROL VALVE INOP".

OPERATIONAL PROCEDURES

Manual Override Start Procedure:

- Ensure communications are in place with maintenance personnel operating the Starter Control Valve manually.
- When ready to start, perform a normal start.
- Ensure maintenance personnel are notified when engine N2 comes to the IDLE.
- Ensure ground personnel are clear after start.

MAINTENANCE PROCEDURES

Manual Override Start Procedure:

- Use the rear (ramp) interphone system for communications between persons on the ramp and in the cockpit.
- Perform TASK 80-10-02-980-801-A (AMM) to start the affected engine using Starter Control Valve Manual Override procedure.
- When the task is complete and all personnel and equipment are clear of the airplane, notify the cockpit.

EICAS Caution Message E1(2) ATS SOV OPN check:

- Access the Starter Control Valve by performing TASK 80-10-02-980-801-A (AMM).
- Airplane..... ENERGIZE
- EICAS Override Switch (cockpit) OVRD
- Starter Control Valve..... OPEN
 Tell the ground personnel to open the Starter Control Valve.
- Check Caution Message E1(2) ATS SOV OPN displayed on the EICAS.
- EICAS Override Switch..... NORM

1-09-80	Page 2	Code 02
---------	-----------	------------

MMEL AMENDMENTS FOR SPECIAL OPERATIONS

INTRODUCTION

The following pages include the requirements related to some special operations that require a more restrictive configuration when comparing with normal operations, in accordance with the applicable AFM supplements.

The special operations considered are:

- Cat II precision approaches.
- HGS AIII precision approaches.
- HGS low visibility take-off.
- Reduced Vertical Separation Minimum (RVSM).
- BRNAV/PRNAV/RNAV 5.
- RNAV 1/RNAV 2.
- ADS-B OUT.

In case of discrepancy of the information presented herein and the approved AFM, the AFM must prevail.



INTENTIONALLY BLANK

SPEC OPS	Page 2	Code 02
----------	-----------	------------

CAT II PRECISION APPROACH

System & Sequence Number	ITEM	1.	2. Number installed		4. Remarks and/or exceptions
			3. Number required for dispatch		
22-10-01	Autopilot/Flight Director Functions				
	1) Autopilot System	1	1		
	2) Flight Director Systems	2	2		
	3) Yaw Damper System	1	1		
22-11-09	Go-Around Buttons	C	2	1	(O) One may be inoperative provided remaining button is checked.
23-00-00	Communications Systems				
	1) VHF communication system	D	-	2	
30-41-00	Windshield Wipers		2	2	NOTE: For airplanes equipped with Rain Repellent Coating (RRC) the use of windshield wipers are not required.
34-24-01	Standby Attitude Indication (on integrated standby instrument (ISIS) or on dedicated instrument		1	1	
					(continued)

DDPM-145/1116



CAT II PRECISION APPROACH

System & Sequence Number	ITEM	1.	2. Number installed		4. Remarks and/or exceptions
			3.	Number required for dispatch	
(continued)					
34-27-00	Inertial Reference System (IRS)	2	2	2	Two must be operative for airplanes with dual IRS configuration. NOTE: For airplanes equipped with dual AHRS configuration, two AHRS must be operative in place of IRS.
		D	1	0	May be inoperative provided IRS is not used as a primary navigation or attitude source.
34-31-00	Radio Altimeter System (Pre-Mod SB145-34-0083)	C	2	1	One must be operative for airplanes with EICAS version 17 or higher provided: a) RA1 must be operative, and b) Affected Radio Altimeter is deactivated.
	(Post-Mod SB145-34-0083)	C	2	1	May be inoperative provided affected radio altimeter is deactivated.
34-32-00	VOR/ILS System 1) Instrument Landing System	C	-	2	
					(continued)

DDPM-145/1116

CAT II PRECISION APPROACH

System & Sequence Number	ITEM	1.	2. Number installed	3. Number required for dispatch	4. Remarks and/or exceptions
(continued)					
34-41-00	Ground Proximity Warning System (GPWS) or Enhanced GPWS	-	1	1	<p>One must be operative for dispatch.</p> <p>NOTE: For airplanes Pre-Mod SB145-34-0083, RA1 must be operative. For airplanes Post-Mod SB145-34-0083, only one RA must be operative.</p>

DDPM-145/1116



HGS AIII MODE PRECISION APPROACH

System & Sequence Number	ITEM	1.	2. Number installed		4. Remarks and/or exceptions
			3. Number required for dispatch		
30-41-00	Windshield Wipers	2	2		NOTE: For airplanes equipped with Rain Repellent Coating (RRC) the use of windshield wipers are not required.
31-42-02	Integrated Computer Configuration Modules (IM-600)	2	2		Two must be operative for dispatch. NOTE: IM-600 version must be 17 or higher.
34-25-00	Head-Up Guidance System (HGS)	1	1		
34-27-00	Inertial Reference System (IRS)	2	2		Two must be operative for airplanes with dual IRS configuration.
		1	1		One must be operative for airplanes with dual AHRS configuration.
34-31-00	Radio Altimeter System	2	2		
34-32-00	VOR/ILS System 1) Instrument Landing System	3	3		
		-	1		One must be operative for airplanes with single IRS configuration. NOTE: In case of dual GPS configuration, GPS 2 must be operative.
34-56-00	Global Positioning System (GPS)	C	-	0	May be inoperative for airplanes with dual IRS configuration provided alternate procedures are established and used.

DDPM-145/1116

HGS LOW VISIBILITY TAKEOFF

System & Sequence Number	ITEM	1.	2.	Number installed	3. Number required for dispatch	4. Remarks and/or exceptions
30-41-00	Windshield Wipers		2	2	2	NOTE: For airplanes equipped with Rain Repellent Coating (RRC) the use of windshield wipers are not required.
31-42-02	Integrated Computer Configuration Modules (IM-600)		2	2	2	Two must be operative for dispatch. NOTE: IM-600 version must be 17 or higher.
34-25-00	Head-Up Guidance System (HGS)		1	1	1	
34-27-00	Inertial Reference System (IRS)		2	2	2	Two must be operative for airplanes with dual IRS configuration.
			1	1	1	One must be operative for airplanes with dual AHRS configuration.
34-32-00	VOR/ILS System 1) Instrument Landing System		3	3	3	

DDPM-145/1116



RVSM

System & Sequence Number	ITEM	1.	2. Number installed		4. Remarks and/or exceptions
			3.	3. Number required for dispatch	
22-10-00	Autopilot/Flight Director Functions				
	1) Autopilot System	1	1		Autopilot with Altitude Hold Mode must be operative.
	2) Flight Director System	C	2	1	One must be operative for dispatch.
	3) Yaw Damper System	1	1		One must be operative for dispatch. NOTE: Autopilot will not engage with yaw damper inoperative.
30-31-00	Pitot/Static Heating Systems	C	3	2	(M) One may be inoperative provided: a) Standby and remaining Pitot/Static Heating Systems operate normally, and b) Airplane is not operated in visible moisture, or in known or forecast icing/rain conditions. NOTE: Static Ports Heating must be operative.
34-31-01	Altitude Alerter Function	1	1	1	One must be operative for dispatch. NOTE: Altitude Preselect Function must be operative.
34-52-00	ATC Transponder and Automatic Altitude Reporting System	C	-	1	One must be operative for dispatch.

DDPM-145/1116

BRNAV/PRNAV/RNAV 5

System & Sequence Number	ITEM	1.	2. Number installed		3. Number required for dispatch	4. Remarks and/or exceptions
22-10-00	Autopilot/Flight Director Functions					
	2) Flight Director System	C	2	1		Flying pilot's Flight Director must be operative for dispatch.
34-51-00	Distance Measuring Equipment (DME) Systems	C	-	0		May be inoperative provided navigation is based only on GPS signals.
		C	-	1		One must be operative for dispatch provided navigation is based only on DME signals. NOTE: Navigation based on VOR/DME signals is allowable.
34-56-00	Global Positioning System (GPS)	C	-	0		May be inoperative provided navigation is based only on DME signals.
		C	-	1		One must be operative for dispatch provided navigation is based only on GPS signals.
34-60-00	Flight Management System	C	-	1		One must be operative for dispatch.

DDPM-145/1116



RNAV 1/RNAV 2

System & Sequence Number	ITEM	1.	2. Number installed		4. Remarks and/or exceptions
			3.	Number required for dispatch	
22-10-00	Autopilot/Flight Director Functions				
	2) Flight Director System	C	2	1	Flying pilot's Flight Director must be operative for dispatch.
34-27-00	Inertial Reference System (airplanes equipped with FMS Honeywell)		2	2	NOTE: For airplanes equipped with two AHRS and one additional IRS dedicated to HGS, only navigation based on GPS is allowable.
34-51-00	Distance Measuring Equipment (DME) Systems	C	-	0	May be inoperative provided navigation is based only on GPS signals.
		C	-	1	One must be operative for dispatch provided navigation is based on DME/DME/IRS signals. NOTE: For airplanes equipped with AHRS, only navigation based on GPS is allowable.
34-56-00	Global Positioning System (GPS)	C	-	0	May be inoperative provided navigation is based on DME/DME/IRS signals.
		C	-	1	One must be operative for dispatch provided navigation is based only on GPS signals.
34-60-00	Flight Management System	C	-	1	One must be operative for dispatch.

DDPM-145/1116

ADS-B OUT

System & Sequence Number	ITEM	1.	2. Number installed		4. Remarks and/or exceptions
			3. Number required for dispatch		
34-52-00	ATC Transponder and Automatic Altitude Reporting System	C	-	1	
34-56-00	Global Positioning System	C	-	1	

DDPM-145/1116

REVISION 12

SPEC OPS	Page 11	Code 02
----------	------------	------------



INTENTIONALLY BLANK

SPEC OPS	Page 12	Code 02
----------	------------	------------

NON ESSENTIAL EQUIPMENT AND FURNISHINGS (NEF) LIST

INTRODUCTION

The purpose of this document is to introduce the new term and definition for Non-essential Equipment and Furnishings (NEF).

Prior to issuance of Policy Letter 116, the FAA Master Minimum Equipment List (MMEL) provided relief for Passenger Convenience Items (PCI) that limited relief to the cabin, galley, and lavatory areas. Many operators deferred inoperative, damaged, or missing equipment or instruments not located in these areas via means other than the Minimum Equipment List (MEL) or Configuration Deviation List (CDL).

Other than under the provisions of an approved MEL or CDL, the regulations do not provide for the deferral of inoperative, damaged, or missing equipment or instruments. Because the PCI is limited to the areas described above, the FAA is replacing the current PCI title in ATA chapter 25 of all MMELs with the new term, NEF.

Operators may use the deferral authority granted in the MMEL as a basis for developing an operator-specific program, approved through the MEL, that provides relief for inoperative, damaged, or missing non-essential equipment and furnishings located throughout the airplane. Although the NEF program is listed under chapter 25, it may address items that would fall under other ATA chapters.

General guidance for development and approval of an operator's NEF:

- FAA Order 8300.10, volume 2, chapter 7
- FAA Order 8400.10, volume 4, chapter 4
- MMEL Global Change GC-138 (PL-116)
- NEF Universal List (PL-116 attachment)

NOTE: The following NEF list was made in order to facilitate development of operator's NEF program. This list is not all inclusive and does not include all items that may be appropriate for deferral under an operator's NEF program. Some items on the list may not be appropriate according to airplane's configuration. Any NEF list developed by operator must be submitted to the FAA for review and approval as part of their NEF program.



NONESSENTIAL EQUIPMENT AND FURNISHINGS

NEF are those items installed on the airplane as part of the original type certification, supplemental type certificate, or other form of alteration that have no effect on the safe operation of flight and would not be required by the applicable certification rules or operational rules. They are those items that, if inoperative, damaged, or missing, have no effect on the airplane's ability to be operated safely under all operational conditions. These nonessential items may be installed in areas including, but not limited to, the passenger compartment, flight deck area, service areas, cargo areas, crew rest areas, lavatories, and galley areas. NEF items are not items already identified in the MEL or CDL of the applicable airplane. They do not include items that are functionally required to meet the certification rule or for compliance with any operational rule. The operator's NEF process shall not provide for deferral of items within serviceable limits identified in the manufacturer's maintenance manual or operator's approved maintenance program such as wear limits, fuel/hydraulic leak rates, oil consumption, etc. Cosmetic items that are fully serviceable but worn or soiled may be deferred under an operator's NEF process.

By definition, NEF items do not affect the safe operation of an airplane. Due to the wide variance of these items from airplane to airplane, a complete list of NEF items is not required to be maintained in the operator's MEL, but in a list or other equivalent method of tracking.

NEF items do not go through the normal FOEB process and will be managed by the Certificate Holding District Office (CHDO). The fundamental elements for an operator obtaining approval of an NEF program is the operator's development of procedures and processes for identifying items that may be deferred, development of appropriate procedures, documentation of inoperative, damaged or missing items, reporting of deferrals to the FAA office charged with program oversight, and procedures for follow-up maintenance. It is not necessary, nor preferred, that every item be listed in the MEL.

Operators need not incorporate a list of NEF items in the MEL, but it is probably advantageous for the operator to develop an NEF list (or its equivalent) in the NEF program. Development of such a list will reduce both the operator's and the FAA's time spent analyzing recurring deferrals of the same items.

NEF	Page 2	Code 02
-----	-----------	------------



DISPATCH DEVIATIONS PROCEDURES MANUAL

NEF LIST

An NEF list (or equivalent) will also provide flight crews, maintenance, and operations personnel, if applicable, with any applicable M & O procedures necessary for the safe operation of the airplane. If an operator chooses to develop a list of NEF items, that list can be maintained in a manner and location agreed to by the CHDO. Operators may specify a repair time frame for the NEF items and may use the current MEL deferral categories at their discretion.

DDPM-145/1116

REVISION 9

NEF	Page 3	Code 02
-----	-----------	------------

**DISPATCH
DEVIATIONS
PROCEDURES
MANUAL**



INTENTIONALLY BLANK

NEF	Page 4	Code 02
-----	-----------	------------

REVISION 9

DDPM-145/1116

NEF LIST

DESCRIPTION	REMARKS AND/OR EXCEPTIONS
11 PLACARDS AND MARKINGS	
Interior Placards and/or Markings	Non required placards may be missing or damaged. (M) Required placards will be identified by maintenance and may be degraded but legible.
Exterior Placards and/or Markings	Non required placards may be missing or damaged. (M) Required placards will be identified by maintenance and may be degraded but legible.
21 AIR CONDITIONING	
Air Conditioning Service Bays Dust Cap Chains and/or Lanyards	May be missing or damaged.
24 ELECTRICAL POWER	
Battery Compartment Dust Caps/Covers	May be missing or damaged.
Hold Open Rods/Lanyards	May be missing or damaged.
25 EQUIPMENT AND FURNISHINGS (FLIGHT COMPARTMENT)	
Trim/Covers/Lenses and Caps	May be missing or damaged.
Crew Gasper Outlets	May be inoperative or damaged.
Logo Insignia	May be missing or damaged.
Pen Holders	May be missing or damaged.
Floor Boards/Floor Coverings	May be soiled or worn.
Crew Seat Upholstery	May be soiled or worn.
Crew Seat Trim	May be missing or damaged.
Access Compartment Latches	May be missing or damaged.
Coat/Hat Hooks	May be missing or damaged.

**DISPATCH
DEVIATIONS
PROCEDURES
MANUAL**



DESCRIPTION	REMARKS AND/OR EXCEPTIONS
25 EQUIPMENT AND FURNISHINGS (FLIGHT COMPARTMENT)	
Circuit Breaker Guards/Collars	May be missing or damaged.
Document Holder	May be missing or damaged.
Spare Bulb Kit and Contents	May be missing or damaged.
Microphone Holder	May be missing or damaged.
Middle Grab Handle	May be missing or damaged.
Cockpit Lining	May be damaged provided: a) Holes and free components are not allowable, and b) Cracks are acceptable since correct panel mounting is not affected.
Protector Overhead Panel	May be damaged provided: a) Holes are not allowable, and b) Cracks are acceptable since correct panel mounting is not affected.
Pedal Assembly Lining	May be damaged provided: a) Holes are not allowable, and b) Cracks are acceptable since correct panel mounting is not affected.
Glareshield Coverage	May be damaged provided: a) Holes and free components are not allowable, and b) Cracks are acceptable since correct panel mounting is not affected.
Control Column Linings	May be damaged provided flight controls operate normally.
Cockpit Pedal Covers	May be damaged provided: a) Holes and free components are not allowable, and b) Cracks are acceptable since correct panel mounting is not affected.
Cockpit Ashtray(s)	May be missing or damaged.
Cockpit Cup Holders	May be missing or damaged.
Cockpit Foot Rests	May be missing or damaged.
Control Yoke Rubber Hand Grip	May be missing or damaged.
Cockpit Seat Headrest(s)	May be missing or damaged.

DESCRIPTION	REMARKS AND/OR EXCEPTIONS
25 EQUIPMENT AND FURNISHINGS (FLIGHT COMPARTMENT)	
Cockpit Finishing Parts	May be stained/torn/damaged provided: a) Holes are not allowable, and b) Cracks are acceptable since correct panel mounting is not affected.
Window Sunshade	May be missing or damaged.
25 EQUIPMENT AND FURNISHINGS (PAX COMPARTMENT)	
Trim/Covers/Lenses and Caps	May be missing or damaged.
Carpet/Floor Covering	May be soiled or worn.
Seat Track Covers	May be missing or damaged.
Wall Coverings	(M) May be worn or damaged provided do not exceed damage limits allowed according to SRM.
Ancillary Kit	May be missing or incomplete.
Demo Equipment	Any in excess of those required may be inoperative or missing.
AED Hold Down Strap	May be worn or damaged.
Seat Belt Extenders	May be missing.
Passenger Seat Trim	May be missing or damaged or worn provided seat operation is not affected.
Individual Passenger Gasper Outlets	May be inoperative or damaged.
Passenger Reading Lights	May be inoperative or damaged.
Seat Headsets (adjustable type)	May be inoperative.
Flight Attendant Seat Trim or Coverings	May be missing or damaged provided function of the seat is not compromised.
Jump Seat Reading Lights	May be inoperative provided remaining lighting is sufficient for cabin attendant to perform assigned duties.

DDPM-145/1116

**DISPATCH
DEVIATIONS
PROCEDURES
MANUAL**



DESCRIPTION	REMARKS AND/OR EXCEPTIONS
25 EQUIPMENT AND FURNISHINGS (PAX COMPARTMENT)	
Headliner	May be damaged provided: a) Holes components are not allowable, and b) Cracks are acceptable since correct panel mounting is not affected. (M) Check damage does not pose any safety hazard to occupants and must not impede emergency egress.
PSU/Service Unit	May be damaged provided oxygen masks work properly. (M) Check damage does not pose any safety hazard to occupants and must not impede emergency egress.
Overhead Bin Trim/Dust Covers/Strips/Caps	May be inoperative or missing provided bin functions normally.
Sidewall Lining Panels	May be damaged/loose provided damage at emergency window region and free panel is not allowable. (M) Check damage does not pose any safety hazard to occupants and must not impede emergency egress.
Skirting Lining Panels	May be damaged provided free panel is not allowable. (M) Check damage does not pose any safety hazard to occupants and must not impede emergency egress.
Main Door Lining Panels	May be damaged/loose and mandatory placards are installed.
Service Door Lining Panels	May be damaged/loose and mandatory placards are installed.
Main-Door Trim Shroud Assembly	May be damaged.
Service-Door Trim Shroud Assembly	May be damaged provided handle stays firm.
Escape-Hatch Trim Shroud Assembly	May be damaged provided emergency exit works properly.

DESCRIPTION	REMARKS AND/OR EXCEPTIONS
25 EQUIPMENT AND FURNISHINGS (PAX COMPARTMENT)	
Window Reveal Assembly	May be crazed/moisture between panes and damaged is allowable only at window frame. (M) Check damage does not pose any safety hazard to occupants and must not impede emergency egress.
LH/RH Valance Panel	May be damaged/loose.
Escutcheon	May be damaged/loose.
Windows Transparency	May be dirty/minor insignificant damage.
Windows Shade	May be damaged/will not move.
Closets Trim/Panel/Hangers/Shelves	May be missing, damaged or worn.
Passenger Cabin Floor Lining	May be stained/torn/worn. (M) Check for no delamination at floor panel, check striplight in order to not pose any safety hazard to occupants and must not impede emergency egress.
Cockpit-Passenger Cabin Partition	May be stained/torn/worn. (M) Check for no delamination at panels.
Forward Baggage Compartment Partition	May be damaged provided do not exceed maximum and type of damage limits allowed according to AMM 25-27-02-8.
Toilet Partition-Aft Compartment Partition	(M) May be damaged/stained/torn/worn provided door and blow-out panels works properly. In case of slide door installed, check for panel delamination.
LH/RH Windscreen	May be dirty/minor insignificant damage.
Main Door Curtain/Curtains	May be damaged/torn.
Aft Compartment Curtain	May be damaged/torn.
Galley Curtain	May be damaged/torn.
Aft Cabin Partition	May be stained/torn/worn.
Cockpit Cabin Curtain	May be damaged/torn.

DDPM-145/1116

**DISPATCH
DEVIATIONS
PROCEDURES
MANUAL**



DESCRIPTION	REMARKS AND/OR EXCEPTIONS
25 EQUIPMENT AND FURNISHINGS (PAX COMPARTMENT)	
Forward Compartment Partition	May be damaged.
Class Partition	May be stained/torn/worn.
Class Curtain	May be damaged/torn.
Lavatory/Baggage Door Microswitch	May be damaged.
Aft Cabin Curtain	May be damaged/torn.
Forward Cabin Curtain	May be damaged/torn.
Aft Pocket Door Cover	May be damaged/loose.
Forward Pocket Door Cover	May be damaged/loose.
25 EQUIPMENT AND FURNISHINGS (GALLEY)	
Mirrors	May be damaged.
Galley Work Tables	May be inoperative or missing.
Galley Floor Mats	May be worn, soiled or missing.
Forward/Aft Galley	May be damaged/loose provided damage at attachments region is not allowable.
Outboard Galley	May be damaged/loose provided damage at attachments region is not allowable.
LH/RH Galley	May be damaged/loose provided damage at attachments region is not allowable.
Hot Jug	May be inoperative provided will not heat.
Oven	May be inoperative provided will not heat.
Microwave	May be inoperative provided will not heat.
Coffee Maker	May be inoperative provided will not heat.
Galley Microswitches	May be inoperative.
Refrigerator	May be inoperative provided will not refrigerate.
25 EQUIPMENT AND FURNISHINGS (LAVATORIES)	
Lavatory Assist Handles	May be missing or damaged.
Diaper Changing Table	May be missing or damaged.
Seal Strip on Lavatory Door	May be missing or damaged.
Soap or Sanitizer Dispenser	May be missing or damaged.

DESCRIPTION	REMARKS AND/OR EXCEPTIONS
25 EQUIPMENT AND FURNISHINGS (LAVATORIES)	
Toilet Paper Roller	May be missing or damaged.
Toilet Seat	May be inoperative or missing.
Toilet Seat Lid	May be inoperative or missing.
Lavatory Door Lock	(M) May be inoperative provided lavatory is considered inoperative and secured closed.
Lavatory Door	May be damaged provided damage is insignificant and door must be checked.
Toilet Shroud Assembly	(M) May be damaged provided damage does not pose any safety hazard to occupants.
Lavatory Closet Assembly	(M) May be damaged provided damage does not pose any safety hazard to occupants.
Lavatory Soap Dispenser	(M) May be broken/missing provided alternate procedures are established and used.
Vanity Mirror	May be damaged.
Vanity Mirror Lights	May be inoperative or missing.
Sink Drain Screen	May be inoperative or missing.
Soap Holder	May be inoperative or missing.
Faucet Aerator	May be inoperative or missing.
Hot and Cold Faucet Indicators	May be inoperative or missing.
Deodorizer Holder	May be inoperative or missing.
Paper Towel or Tissue Holder	May be inoperative or missing.
Interior Wall Trim or Coverings	May be worn or damaged.
Air Grill Covers	May be missing or damaged.
Floor Mats	May be missing or damaged.
Lavatory Slide Door	May be damaged provided damage is insignificant and door must be checked.
Aft Pocket Door	May be damaged.
Lavatory Swing Door	May be damaged.
Lavatory Door Latch	(M) May be inoperative provided lavatory is considered inoperative and secured closed.

DDPM-145/1116

**DISPATCH
DEVIATIONS
PROCEDURES
MANUAL**



DESCRIPTION	REMARKS AND/OR EXCEPTIONS
25 EQUIPMENT AND FURNISHINGS (BAGGAGE COMPARTMENT)	
Trim Piece	(M) May be damaged provided fire resistance or sealed compartment integrity is not compromised. Refer to AMM/SRM for allowable limits.
Grills Smoke Detector or Vent	May be damaged.
Cargo Floor Panels	(M) May be worn or damaged. Refer to AMM/SRM for allowable limits.
Anti-skid Paint	May be worn, soiled or missing.
Non Slip Tape	May be worn, soiled or missing.
Baggage Compartment Anti Blockage Barrier	May be damaged provided do not exceed Anti-Blockage Barrier repair limits according to AMM 25-50-01-8.
Cargo Loading/Unloading Ramp	May be damaged provided damage does not affect correct door closing or does not pose any damage to the baggage.
Ramp Assembly	May be damaged.
Towbar Head Support and Towbar Support	May be damaged/loose.
Coat Hanger	May be damaged/loose.
Baggage Door Lining	May be damaged.
Baggage Compartment Floor Lining	May be damaged provided damage does not affect floor panel.
25 EQUIPMENT AND FURNISHINGS (EMERGENCY)	
Emergency Floor Light Cover	May be damaged.
28 FUEL	
Fuel Cap Lanyard	May be missing or damaged.
29 HYDRAULIC POWER	
Hydraulic Service Bays Dust Cover Caps for Service Ports	May be missing or damaged.
Dust Cap Chains or Lanyards	May be missing or damaged.

DESCRIPTION	REMARKS AND/OR EXCEPTIONS
38 WATER/WASTE	
Lavatory Service Dust Caps for Service Ports	May be missing or damaged.
Dust Cap Chains or Lanyards	May be missing or damaged.
52 DOORS	
Main Passenger Door Internal Trim	May be missing or damaged.
Main Door Trim Panel or Fairing	May be damaged.
Door Panel Lanyards	May be missing or damaged.
Cargo Door Rubber Trim Seal or Dust Seal	May be missing or damaged.
Cargo Door Trim Panel or Fairing	May be missing or damaged.
Service Door Rubber Trim Seal or Dust Seal	May be missing or damaged.
Service Door Trim Panel or Fairing	May be damaged.
53 FUSELAGE	
Fuselage Paint/Company Colors	May be missing or damage.

**DISPATCH
DEVIATIONS
PROCEDURES
MANUAL**



INTENTIONALLY BLANK

NEF	Page 14	Code 02
-----	------------	------------

REVISION 9

DDPM-145/1116

INTRODUCTION

This section presents information that may be used when dispatching the airplane with selected configuration deviations, for which revenue operation is not allowed by the MMEL or CDL, and when it is necessary to ferry the airplane to a base where repairs, modification, or maintenance are to be performed.

The procedures presented herein must be used for a flight or series of flights necessary to return the airplane to the next available maintenance base. No passengers are allowed on board. Only required crewmembers can be carried aboard during ferry flights.

The procedures established herein are based on the assumption that all airplane systems are operating normally and that the integrity of the structure is not affected except by those systems or parts that are being dispatched in the ferry-flight condition.

Since variables such as airplane configuration, airline routes, special operational procedures, and the maintenance practices of the airline itself may affect a given procedure, it is recommended that each operator review the procedures presented herein to verify that the airplane is capable of performing a safe flight and to ensure that they are suitable for this particular operation. It is the company's responsibility to exercise good judgment to evaluate factors such as airplane condition, weather, etc.

The use of the information contained herein is for guidance purposes only, not being mandatory for the operator to use it.

CAUTION: DIFFERENCES IN CONFIGURATION OR CONDITIONS CAN INVALIDATE THE FERRY FLIGHT INFORMATION PRESENTED IN THIS SECTION.

- NOTE:** - Special approval from regulatory authorities must be obtained to use the information contained in this DDPM section.
- EMBRAER Structures, Systems, RTS and Flight Support Engineering Teams are at your disposal to provide technical guidance for conditions not covered in this section, on a case-by-case basis.

**DISPATCH
DEVIATIONS
PROCEDURES
MANUAL**



INTENTIONALLY BLANK

FERRY	Page 2	Code 02
-------	-----------	------------

REVISION 9

DDPM-145/1116

FERRY FLIGHT FOR DEACTIVATED SPOILER

The information presented in this Section, associated with the basic AFM, enables the establishment of the conditions required to accomplish the ferry flight operation with spoiler deactivated. For limitations, procedures, and performance information not contained in this Section, refer to the AFM and/or applicable Supplements.

This procedure is applicable to the EMB-135 and EMB-145 models operating under ANAC, FAA and EASA certification.

MAINTENANCE PROCEDURE

- Pull and secure SPEED BRAKE, GND SPLR OUTBD, GND SPLR INBD and spoiler IND circuit breakers and attach a DO-NOT-CLOSE tag to them.
- Make sure that the flaps are in the 0° position.
- Open Maintenance Panel door.
- Energize the airplane with the Electrical DC Power Supply.
- Set both hydraulic ELEC PUMP switch to ON.
- Check for no spoiler surfaces movement:
 - Set engine thrust lever to IDLE;
 - On the maintenance panel, set the SPOILER switch to the TEST position and hold it in this position;
 - Check for no ground spoiler panels movement.
- Close Maintenance Panel door.
- Set both hydraulic ELEC PUMP switch to OFF.
- Deenergize the airplane.

LIMITATIONS

OPERATIONAL LIMITATIONS

KINDS OF OPERATION

- Operation in icing conditions is prohibited;
- CAT I;
- Visual (VFR);
- Instrument (IFR);
- Dry Runway.



OCCUPANTS

No passengers are allowed on board. Only required crewmembers can be carried aboard during this ferry flight.

AUTOPILOT

Do not use the autopilot.

FLIGHT CONTROLS

The speed brake system and ground spoiler system are deactivated. Do not actuate the speed brake lever.

THRUST REVERSER

Thrust reversers must be operative.

NORMAL PROCEDURES

Normal procedures remain unchanged, except that:

- The EICAS message SPOILER FAIL will be displayed;
- Takeoff with flaps 9°;
- The speed brakes must not be commanded to open (placard as appropriate);
- During landing, lower nose wheel immediately to the runway. It will decrease lift and will increase main gear loading;
- Land with flaps 45°;
- Landing must be performed out of icing conditions, and destination runway must not be contaminated.

EMERGENCY AND ABNORMAL PROCEDURES

Emergency and abnormal procedures remain unchanged, except that the speed brakes must not be commanded to open (placard as appropriate).

PERFORMANCE

The following actions complement the performance calculations procedures contained in the AFM.

TAKEOFF

The takeoff performance calculation is based in the previous limitations.

It is applicable to all airplanes takeoff operational envelope in the following configuration:

- Flap: 9°;
- V_2 : 1.20 V_s (or 1.25 V_s , if applicable);
- DRY Runway.

To determine the takeoff distance, multiply the balanced Takeoff Distance for flap 9° by 1.20.

LANDING

The landing performance is based in the previous limitations.

It is applicable to all airplanes landing operational envelope in the following configuration:

- Flap: 45°;
- V_{ref} : 1.23 V_S ;
- DRY Runway.

To determine the landing distance, multiply the unfactored Landing Distance for flap 45° by 1.60.

**DISPATCH
DEVIATIONS
PROCEDURES
MANUAL**



INTENTIONALLY BLANK

FERRY	Page 6	Code 02
-------	-----------	------------

FERRY FLIGHT WITH CREW OXYGEN CYLINDER EMPTY OR WITH LOW PRESSURE

The information presented in this Section, associated with the basic AFM, enables the establishment of the conditions required to accomplish the ferry flight operation with the crew oxygen cylinder empty, or below the minimum pressure for dispatch as follows:

For EMB-135BJ (Legacy 600/650) models:

- Pilot and copilot: 1130 psi.
- Pilot, copilot and observer: 1570 psi.

For EMB-145 models (ERJ-135/140/145/145XR):

- Pilot and copilot: 1100 psi.
- Pilot, copilot and observer: 1500 psi.

This ferry flight must be accomplished to the nearest airport that provide refilling/repair service to reduce the exposure time to any in-flight fire/smoke event.

NOTE: Caution CREW OXY LO PRESS EICAS message may be displayed.

For limitations, procedures, and performance information not contained in this Section, refer to the basic AFM and/or applicable Supplements.

The information presented herein is applicable to the EMB-135BJ (Legacy 600/650) models and EMB-145 (ERJ-135/140/145/145XR) models operating under ANAC, FAA and EASA certification.

LIMITATIONS

OPERATIONAL LIMITATIONS

ALTITUDE

Maximum Operating Altitude 10000 ft

KINDS OF OPERATION

The Kinds of Operation information remains unchanged.



OCCUPANTS

No passengers are allowed on board. Only both pilots can be carried aboard during this ferry flight. An additional crewmember may be seat in the cabin passenger area to deal with in-flight fire or smoke in case of such occurrence.

NORMAL PROCEDURES

The actions listed below complement the procedures contained in the basic AFM. All the other Normal Procedures remain unchanged.

COCKPIT SAFETY INSPECTION

Protective Breathing Equipment (PBE)..... CHECK

Check that at least two PBE's are available in the cockpit.

Cockpit Door OPEN

The cockpit door must remain open during entire flight.

BEFORE TAKEOFF

Air Conditioning/Pneumatic Panel SET

EMERGENCY AND ABNORMAL PROCEDURES

The actions listed below complement the procedures contained in the basic AFM. All the other Emergency and Abnormal Procedures remain unchanged.

SMOKE PROCEDURES

In case of in-flight smoke, the smoke procedures remain unchanged, but some few further considerations apply, as follows:

- Oxygen masks should not be donned, unless there is enough oxygen to complete the diversion.
- Consider the use of both PBE's located in the cockpit. They are capable of providing eyes and respiratory protection and oxygen during 15 minutes. Pilots' communication will be more difficult.
- If airflow caused by the RAM AIR and OUT FLOW open will not be enough to clear smoke on the cockpit, consider accomplish a descent.



DISPATCH DEVIATIONS PROCEDURES MANUAL

FERRY FLIGHT

PERFORMANCE

The Performance information remains unchanged.

FLIGHT PLANNING

The Flight Planning information remains unchanged.

DDPM-145/1116

REVISION 11

FERRY	Page 9	Code 02
-------	-----------	------------

**DISPATCH
DEVIATIONS
PROCEDURES
MANUAL**



INTENTIONALLY BLANK

FERRY	Page 10	Code 02
-------	------------	------------

REVISION 11

DDPM-145/1116

UNPRESSURIZED FERRY FLIGHT

The information presented in this Section, associated with the basic AFM, enables the establishment of the conditions required to accomplish a ferry flight operation with unpressurized configuration implemented. In this situation the airplane may be dispatched under MMEL item 21-30-00 (Pressurization Control System) considering both Automatic and Manual modes inoperative and provided the associated instructions and restrictions are followed.

The information presented herein is applicable to the EMB-135BJ (Legacy 600/650) models and EMB-145 (ERJ-135/140/145/145XR) models operating under ANAC, FAA and EASA certification.

MAINTENANCE PROCEDURE

Placard Pressurization Mode Selector Button "AUTO/MAN INOP". Refer to MMEL item 21-31-03 for both outflow valves secured open.

LIMITATIONS

OPERATIONAL LIMITATIONS

Recirculation FansAS REQUIRED
 Altitude10000 FT

OCCUPANTS

No passengers are allowed on board. Only required crewmembers can be carried during this ferry flight.

**DISPATCH
DEVIATIONS
PROCEDURES
MANUAL**



INTENTIONALLY BLANK

FERRY	Page 12	Code 02
-------	------------	------------

FERRY FLIGHT WITH PASSENGER ADDRESS SYSTEM AND INTERPHONE SYSTEM INOPERATIVE

The information presented in this Section, associated with the basic AFM, enables the establishment of the conditions required to accomplish a ferry flight operation with passenger address system and interphone system inoperative.

The information presented herein is applicable to the EMB-135BJ (Legacy 600/650) models and EMB-145 (ERJ-135/140/145/145XR) models operating under ANAC, FAA and EASA certification.

LIMITATIONS

OCCUPANTS

No passengers are allowed on board. Only required crewmembers can be carried during this ferry flight.

**DISPATCH
DEVIATIONS
PROCEDURES
MANUAL**



INTENTIONALLY BLANK

FERRY	Page 14	Code 02
-------	------------	------------

SPECIAL DISPATCH PROCEDURES

INTRODUCTION

This DDPM section provides operators with information on dispatch of the EMB-145 family for flights with selected items not covered by the CDL or the MMEL. It also provides dispatch information located in other manual like AMM, IPC, etc.

The special dispatch procedures considered is:

- Cracked or Broken External Lights or Lenses.
- Missing/Damaged Bonding Jumpers.



INTENTIONALLY BLANK

SDP	Page 2	Code 02
-----	-----------	------------

CRACKED OR BROKEN EXTERNAL LIGHTS OR LENSES

This Special Dispatch Procedure section is intended to provide Embraer operators with information to dispatch airplane for flight with cracked or broken external light or lenses provided a speed tape is applied to cover the affected or cracked part.

Although the cracked/broken lights and lenses could cause flight delays, they are not classified as a Configuration Deviation List (CDL) items because the lights and lenses are not missing from the airplane.

In order to support operators with information to improve dispatch, Embraer has prepared this DDPM section. All the parts contained here have undergone a dedicated analysis and are allowed to be cracked or broken provided a speed tape is applied to cover the affected or cracked part.

For dispatch with cracked or broken external lights or lenses, check that the cracked or broken part does not present a risk of worsening to the point of breaking completely, allowing loose pieces of glass to fall off of the light assembly during ground or flight operations. Check that there is no movement of the parts of the glass and check that supporting structure holds them tightly.

The affected light or lens must be covered with speed tape and a check must be done once each flight day. To correctly apply the speed tape, see the instruction in the end of this section.

The light or lens must be considered inoperative and deferred in accordance with the MMEL, as presented in the following table. The MMEL repair interval must be obeyed and the time allowed to fly with speed tape cannot be more than 10 days.

Since variables such as airplane configuration, airline routes, special operational procedures, and the maintenance practices of the airline itself may affect a given procedure, it is recommended that each operator review the procedures presented herein to verify that the airplane is capable of performing a safe flight and to ensure that they are suitable for this particular operation.

The use of the information contained herein is for guidance purposes only, not being mandatory for the operator to use it.



Special approval from local regulatory authorities may be required to use of the information contained in this DDPM section.

NOTE: The CDL must be applied if: a) There are cracks on the light/lens that show a risk of a complete breakage; b) The supporting structure does not hold the light/lens tightly.

CRACKED OR BROKEN EXTERNAL LIGHTS OR LENSES	DISPATCH CONDITION
Nose Landing Light (1)	MMEL 33-41-00
Taxi Lights (2)	MMEL 33-42-00
Navigation Light Protective Lens	MMEL 33-43-00
Wing Inspection Light Protective Lens	MMEL 33-44-00
Logotype Light Protective Lens	MMEL 33-46-00
Red Beacon Light Protective Lens	MMEL 33-47-05
Exterior Emergency Light Protective Lens	MMEL 33-50-00

- (1) The affected Landing light must be deactivated by open and secure the associated Circuit Breaker. Location Tip: SHED DC BUS 1/ NOSE LDG LIGHT (WM 33-41-50).
- (2) The affected Taxi lights must be deactivated by open and secure the associated Circuit Breaker. Location Tip: SHED DC BUS 2/ TAXI LIGHTS (WM 33-42-50).

Operators are responsible for ensure that an acceptable level of safety is maintained when operating with multiple cracked or broken lights or lenses.

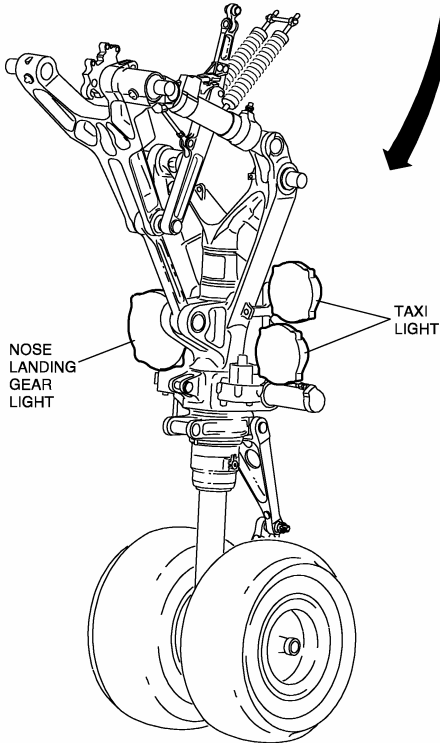
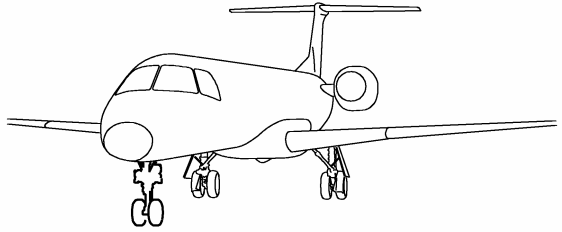

145AOM1080046.MCE

NOSE LANDING AND TAXI LIGHTS

DDPM-145/1116

REVISION 12

SDP	Page 5	Code 02
-----	-----------	------------

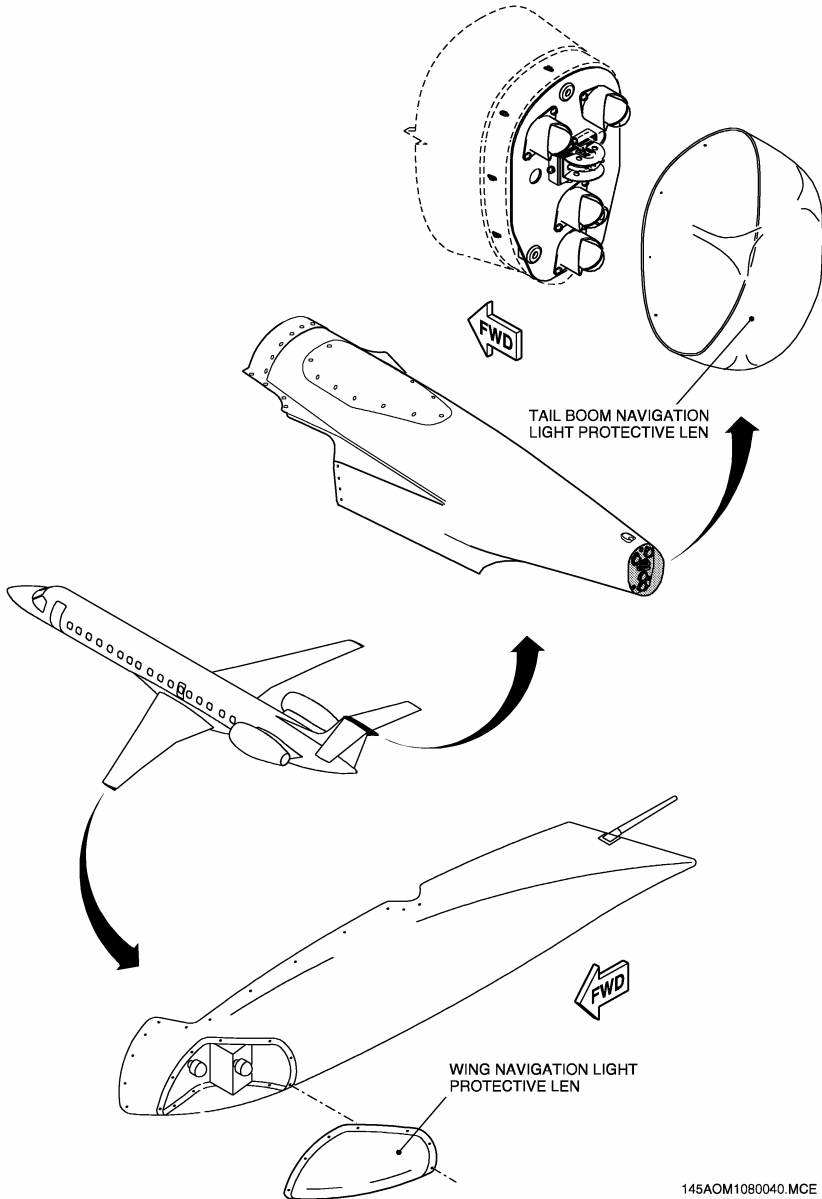

145AOM1080040.MCE

NAVIGATION LIGHT PROTECTIVE LENS

SDP	Page 6	Code 02
-----	-----------	------------

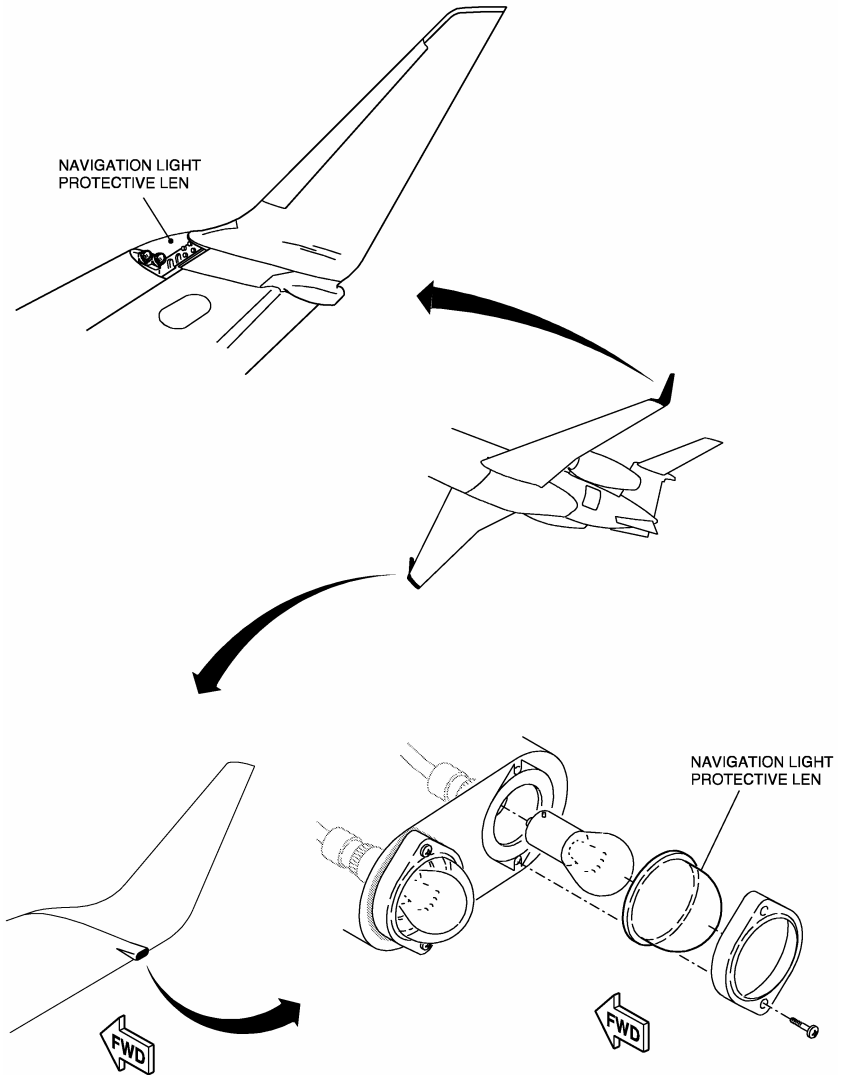

145AOM1080036.MCE

NAVIGATION LIGHT PROTECTIVE LENS

DDPM-145/1116

REVISION 12

SDP	Page 7	Code 02
-----	-----------	------------

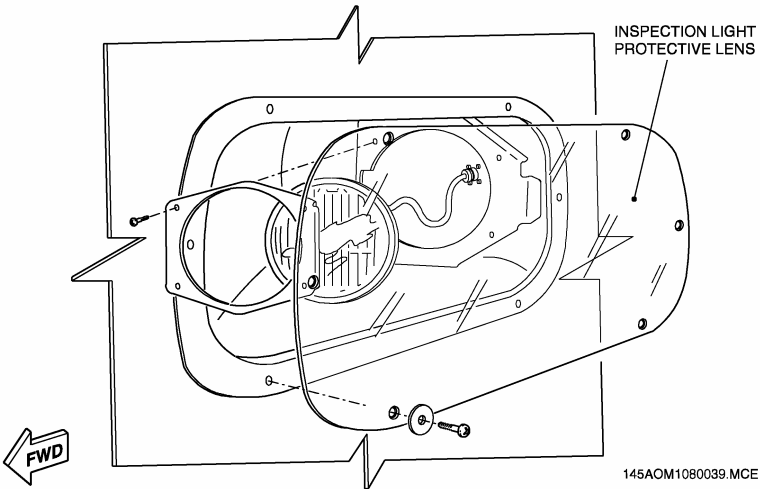
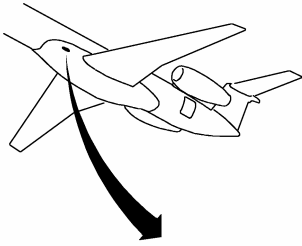

WING INSPECTION LIGHT PROTECTIVE LENS

SDP	Page 8	Code 02
-----	-----------	------------

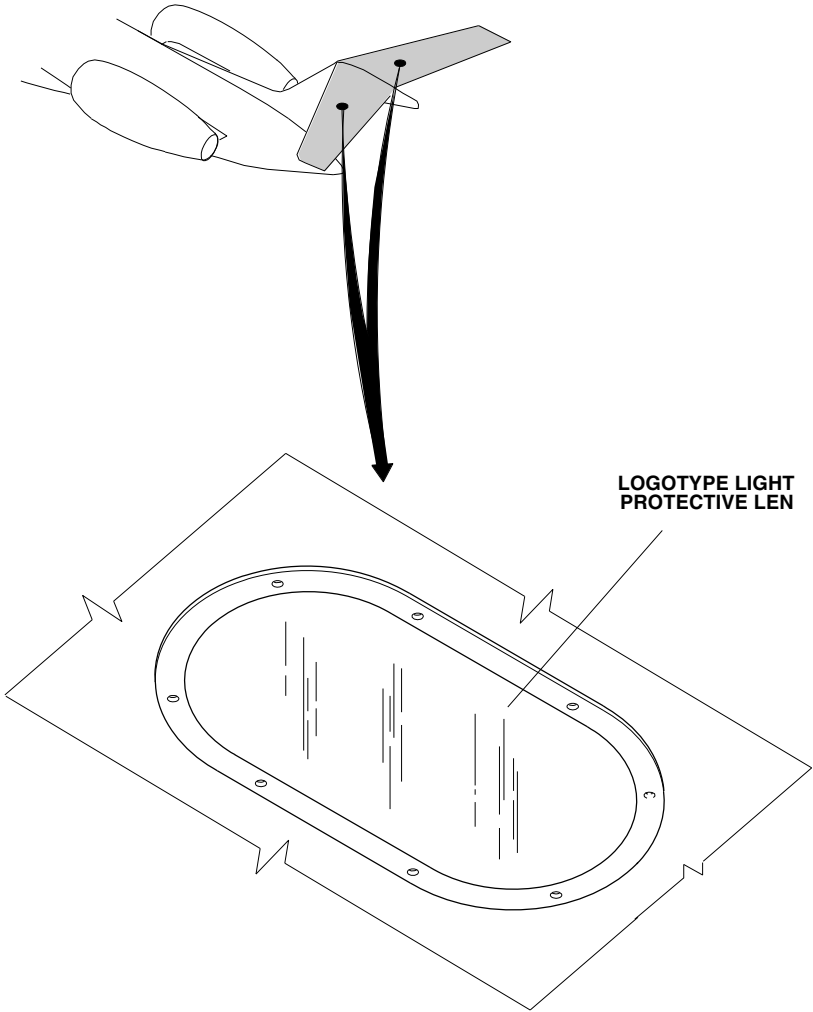

EM145AOM080030A.DGN

LOGOTYPE LIGHT PROTECTIVE LENS

DDPM-145/1116

REVISION 12

SDP	Page 9	Code 02
-----	-----------	------------

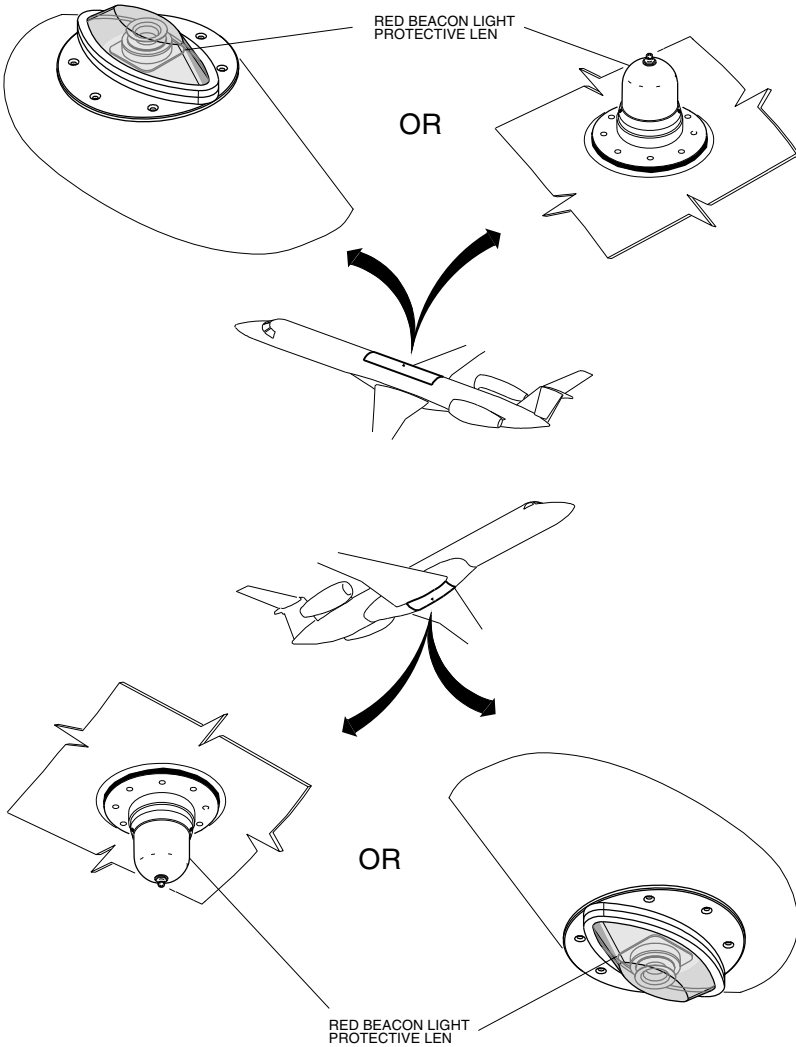

EM145AOM080025A.DGN

RED BEACON LIGHT PROTECTIVE LENS

SDP	Page 10	Code 02
-----	------------	------------

Copyright © by Embraer. Refer to cover page for details.

REVISION 12

DDPM-145/1116

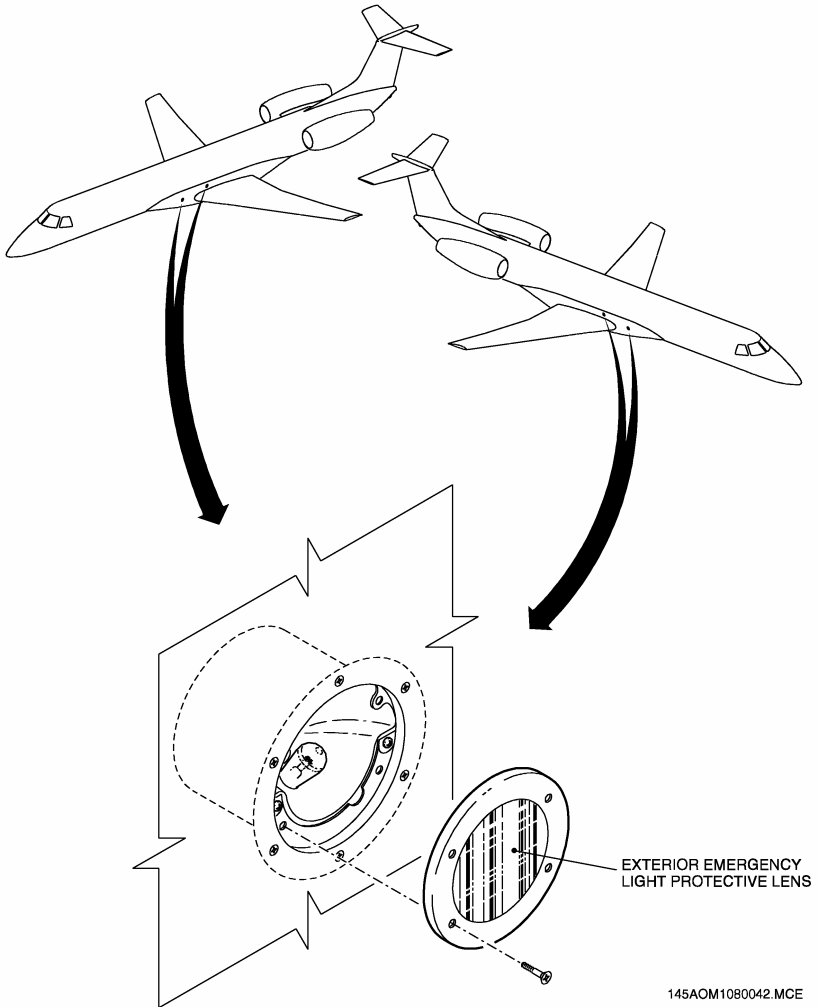

145AOM1080042.MCE

EXTERIOR EMERGENCY LIGHT PROTECTIVE LENS

DDPM-145/1116

REVISION 12

SDP	Page 11	Code 02
-----	------------	------------

APPLICATION OF SPEED TAPE

This procedure gives the instruction to apply speed tape (TAPE 425 100 MM x 30 M).

- 1) Do the required procedures to make the airplane safe for maintenance.
- 2) Cleaning of Area:
 - Clean the area with a lint-free wiper cloth moist with MEK or equivalent.
 - Make sure that you remove all oil, grease, and other residues that you can see.
 - If the lint-free wiper cloth gets dirty during the cleaning procedure, discard it and use a new clean one.
 - Clean the surface with a dry lint-free wiper cloth to remove the remaining solvent from the cleaned area.
- 3) Method "A":
 - This method is applicable to cover cracks or breaks in the external lights or lenses, but is not applicable to the nose gear taxi and landing lights.
 - Apply a layer of speed tape on the damaged part. See the following figure.
 - Make sure that you apply the speed tape with its border perpendicular to the flight direction.
 - Extend the speed tape to a minimum of 76.2 mm (3.0 in) beyond all sides of the light or lens.
 - If the area that you will cover is larger than the speed tape width, add more layers to cover all the area.
 - The layers must have an overlap of 25.4 mm (1.0 in).
 - Make sure that the tape is correctly applied and that there are no signs of air bubbles or wrinkles in it.
- 4) Method "B":
 - This method is applicable only to cover the nose-gear taxi light and the nose-gear landing light, if there is a crack or a broken part on them.
 - Put speed tape on the light, as given in the following figure.
 - The layers of speed tape must have an overlap of 25.4 mm (1.0 in).
 - Make sure that the tape is correctly applied and that there are no signs of air bubbles or wrinkles in it.

SDP	Page 12	Code 02
-----	------------	------------



DISPATCH DEVIATIONS PROCEDURES MANUAL

SPECIAL DISPATCH
PROCEDURES
CRACKED LENSES

5) Speed Tape Inspection:

- Examine the covered area everyday to make sure that there is no disbonding or damaged tape.
- In case of disbonding or damaged tape, replace it with a new one.

DDPM-145/1116

REVISION 12

SDP	Page 13	Code 02
-----	------------	------------

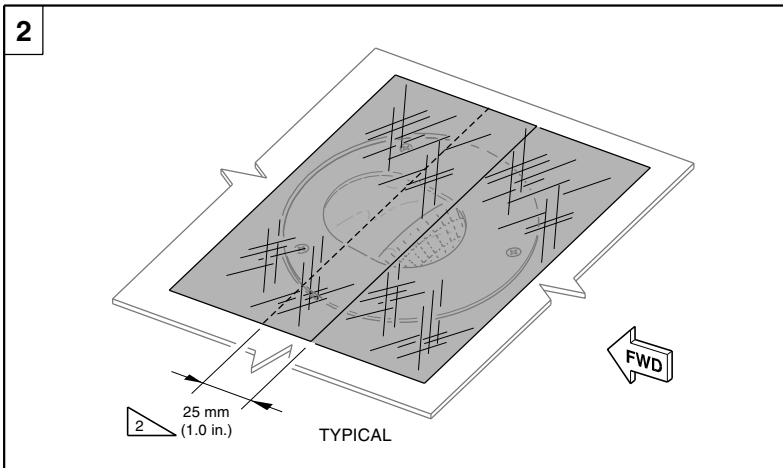
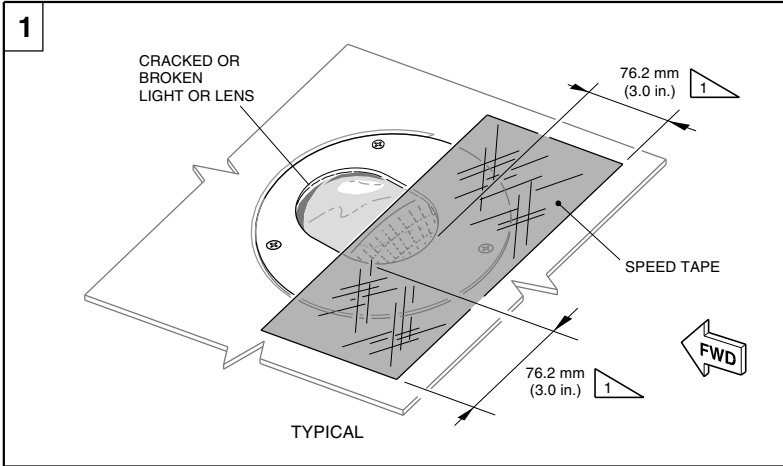

1 EXTEND THE SPEED TAPE A MINIMUM OF 76.2 mm (3.0 in.) BEYOND ALL SIDES OF THE CRACKED OR BROKEN PART.

2 APPLY THE REMAINING LAYERS OF SPEED TAPE OVERLAPPING 25 mm (1.0 in.) THE PREVIOUS ONE.

EM145AOM080029A.DGN

SPEED TAPE _ METHOD A

SDP	Page 14	Code 02
-----	------------	------------

REVISION 12

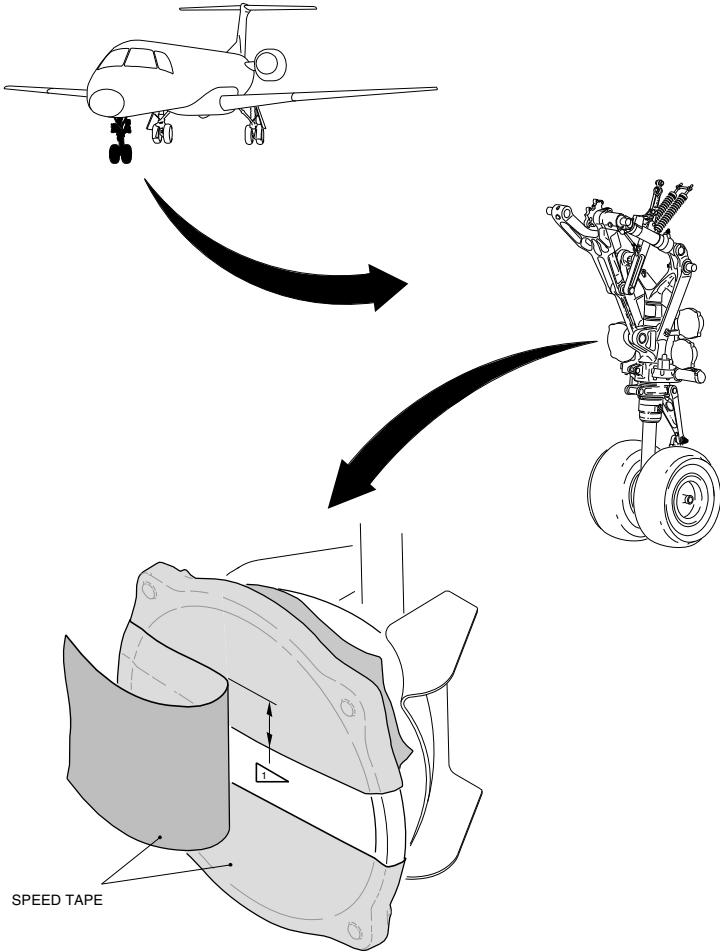

 APPLY THE REMAINING LAYERS OF SPEED TAPE OVERLAPPING 25 mm (1.0 in) THE PREVIOUS ONE.

EM145AOM080031A.DGN

SPEED TAPE _ METHOD B

DDPM-145/1116

REVISION 12

SDP	Page 15	Code 02
-----	------------	------------



INTENTIONALLY BLANK

SDP	Page 16	Code 02
-----	------------	------------

MISSING/DAMAGED BONDING JUMPERS

The bonding jumpers are used as a low-resistance path for conducting electrical current between two parts of the airplane structure.

The bonding jumpers are classified as mandatory or necessary.

Mandatory: Bonding jumpers on areas with high exposure to lightning strikes. These bonding jumpers may not be missing or damaged.

Necessary: Redundant bonding jumpers on airplane areas with less probability of lightning strike. These bonding jumpers may be either missing or damaged, provided there is another bonding jumper in good conditions installed in the same area.

The AMM TASK 20-13-21-210-801-A, Electrical Bonding Map – Standard Procedures, identify mandatory and necessary bonding jumpers. Bonding jumpers not referred in the previously mentioned AMM section are considered mandatory and must not be missing or damaged.

SPECIAL DISPATCH
PROCEDURES
MISSED/DAMAGED
BONDING JUMPERS

**DISPATCH
DEVIATIONS
PROCEDURES
MANUAL**



INTENTIONALLY BLANK

SDP	Page 18	Code 02
-----	------------	------------

Copyright © by Embraer. Refer to cover page for details.

REVISION 12

DDPM-145/1116