



(SCT-02-DGAA13; 2862/2021)
Subsecretaría de Transporte
Agencia Federal de Aviación Civil
Dirección Ejecutiva de Aviación
Dirección de Aviación

4.1.4.1. OPS.-1313/2021.

Ciudad de México, a 15 de abril de 2021.

Link Conexión Aérea, S.A. de C.V.
Blvd. Bernardo Quintana CS 9800,
Piso 7-B706, Centro Sur
C.P. 76090, Querétaro, Qro.

Ing. Gustavo Villafuerte Arredondo
Representante Legal

En atención a su escrito recibido por esta Dirección, el día 30 de marzo del año en curso, y de acuerdo a lo establecido en el Reglamento de la Ley de Aviación Civil y las Normas Oficiales Mexicanas en vigor se devuelve debidamente aprobada la siguiente Enmienda, no teniendo inconveniente en su uso operacional:

MANUAL	Revision
<p align="center">LISTA DE EQUIPO MINIMO (MEL)</p> <p>Aplicable a las aeronaves marca Embraer, modelo ERJ-145, números de serie 145507, 145568, 145481, 145063, 145067, 145075, 145080, 145078, 145138, 145071 y 145241 con matrículas XA-BPK, XA-MFH, XA-RHF, XA-NFP, XA-SFH, XA-JFH, XA-MAF, XA-AFH, XA-PFL, XA-EFH y XA-IFP respectivamente.</p> <p>Los cambios significativos son: Cover Pags 1. Log of Revisions Pags. 3. Effective Pages 4, 5, 6, 7, 8, 9. SYSTEMS. 21-3, 21-4, 22-1, 22-2, 23-5, 24-1, 25-4, 25-5, 25-6, 25-8, 25-10, 27-2, 30-2, 30-3, 33-2, 33-3, 34-7, 34-8, 34-9, 34-10, 35-2, 38-1, 45-1, M & O PROCEDURES. 21-30-00, 21-31-03, 21-51-00, 24-31-01, 25-61-01, 26-12-00, 27-70-00, 30-21-01, 33-47-05, 34-31-00, 34-43-00, 34-52-00, 38-30-00, 45-45-01, 78-30-00 NEF Updated cockpit pedal cover item.</p> <p>(La presente revisión ha sido elaborada conforme a la Revisión número 18 del MMEL de fecha 07/14/2020 emitida por la FAA).</p>	<p align="center">09 26/02/2021</p>

Se devuelven un tanto en papel y un cd, otra copia en electrónico (CD) del manual antes señalado queda en poder del archivo de esta Dirección, debiendo entregar la copia en electrónico anexa al presente a la Comandancia de su base de operaciones, para mantener actualizado el Manual correspondiente en poder de dicha Comandancia de Aeropuerto.

Con base en lo establecido en la Ley de Aviación, así como en los artículos 109 y 131 del Reglamento de la Ley de Aviación Civil, así como en lo establecido en los transitorios Cuarto y Quinto del Decreto por el que se crea el órgano administrativo desconcentrado de la Secretaría de Comunicaciones y Transportes, denominado Agencia Federal de Aviación Civil.

Atentamente,

Ing. Guillermo A. Magaña Hernández
El Director de Aviación

- C.c. Director General de la Agencia Federal de Aviación Civil.- Pte.
- C.c. Director Ejecutivo de Seguridad Aérea.- Pte.
- C.c. Comandancia Regional III Guadalajara.- Apto. Internacional de la Ciudad de Guadalajara – Terminal-II, C.P. 45659, GDL, Jal.- Mismo fin
- C.c. Comandante del Apto. "Intercontinental de Querétaro" – Km. 22.5, Municipio Colon, C.P. 76270, Querétaro, Qro.- Mismo fin.

JAT:MS/DAL

\\10.33.253.201\01_raiz\01_NAC\LINK CONEXIÓN AÉREA S.A. DE C.V\2021\2862-GM-2021 OF APROB REV 06 MEL.docx

Boulevard Adolfo López Mateos 1990, Colonia Los Alpes, C. P. 01010, Alcaldía Álvaro Obregón, CDMX.
T: (55) 5723 9300 www.gob.mx/afac





MINIMUM EQUIPMENT LIST

EMBRAER 145LR

MINIMUM EQUIPMENT LIST



AUTORIZACIÓN AFAC
DIRECCIÓN DE AVIACIÓN
DEPARTAMENTO
DE INGENIERÍA
DE OPERACIONES

DIRECCIÓN DE AVIACIÓN

M MEL

Revision: 18

Date: 07/14/2020

26-febrero-2021

Revisión 09

Página 1

Link Conexión Aérea S.A de C.V.

TABLE OF CONTENTS

	SYSTEM	PAGE NO.
--	Cover	1
--	Table of Contents	2
--	Log of Revisions	3
--	Control Page	4 THRU 6
--	Applicability	8
--	Definitions	9 THRU 12
--	Preamble	13, 14
--	RVSM	15
	EICAS Message List	16 THRU 28
21	Air Conditioning	21-1 THRU 8
22	Autopilot	22-1, 2, 3
23	Communications	23-1 THRU 6
24	Electrical	24-1, 2
25	Equipment / Furnishings	25-1 THRU 9
26	Fire Protection	26-1, 2
27	Flight Controls	27-1, 2
28	Fuel	28-1 THRU 5
29	Hydraulic Power	29-1, 2
30	Ice & Rain Protection	30-1, 2, 3
31	Indicating / Recording Systems	31-1, 2
32	Landing Gear	32-1, 2
33	Lights	33-1, 2, 3
34	Navigation	34-1 THRU 9
35	Oxygen	35-1, 2
36	Pneumatics	36-1, 2
38	Water / Waste	38-1
45	Central Maintenance Computer	45-1
46	Information System	46-1
49	Airborne Auxiliary Power	49-1
52	Doors	52-1
56	Windows	56-1
73	Engine / Fuel Controls	73-1, 2
74	Ignition	74-1
76	Engine Controls	76-1
77	Engine Indicating	77-1
78	Engine Exhaust	78-1
79	Engine Oil	79-1
80	Starting	80-1
--	Guidelines (M) & (O) Procedures	M & O 1 THRU 135
	CDL Configuration Deviation List	CDL 1 THRU 48
	NEF Nonessential Equipment & Furnishings	NEF 1 THRU 12
	ANEXO	ANEX 1 THRU ANEX 2

EFFECTIVE PAGES

SYSTEM	PAGE NO.	REV. NO.	CURRENT DATE
Cover Page	1	Revisión 09	26/02/2021
Table of Contents	2	Re-Edición	04/07/2017
Log of Revisions	3	Revisión 09	26/02/2021
Effective Pages	4	Revisión 09	26/02/2021
	5	Revisión 09	26/02/2021
	6	Revisión 09	26/02/2021
	7	Revisión 09	26/02/2021
	8	Revisión 09	26/02/2021
	9	Revisión 09	26/02/2021
Applicability	10	Revisión 08	19/12/2019
Definitions	11 THRU 13	Revisión 08	19/12/2019
	14	Re-Edición	08/12/2014
Preamble	15 THRU 16	Re-Edición	08/12/2014
RVSM	17	Revision 04	28/01/2016
EICAS Message List	18 THRU 30	Revision 04	28/01/2016
21	21-1	Re-Edición	08/12/2014
	21-2	Re-Edición	08/12/2014
	21-3	Revisión 09	26/02/2021
	21-4	Revisión 09	26/02/2021
	21-5	Re-Edición	08/12/2014
	21-6	Re-Edición	08/12/2014
	21-7	Re-Edición	08/12/2014
	21-8	Re-Edición	08/12/2014
22	22-1	Revisión 09	26/02/2021
	22-2	Revisión 09	26/02/2021
	22-3	Re-Edición	08/12/2014
23	23-1	Revisión 07	04/07/2017
	23-2	Revisión 07	04/07/2017
	23-3	Revisión 07	04/07/2017
	23-4	Revisión 07	04/07/2017
	23-5	Revisión 09	26/02/2021
	23-6	Revisión 07	04/07/2017
24	24-1	Revisión 09	26/02/2021
	24-2	Re-Edición	08/12/2014
25	25-1	Re-Edición	08/12/2014
	25-2	Re-Edición	08/12/2014
	25-3	Revisión 07	04/07/2017
	25-4	Revisión 09	26/02/2021
	25-5	Revisión 09	26/02/2021
	25-6	Revisión 09	26/02/2021
	25-7	Re-Edición	08/12/2014
	25-8	Revisión 09	26/02/2021
	25-9	Revisión 07	04/07/2017
	25-10	Revisión 09	26/02/2021

SYSTEM	PAGE NO.	REV. NO.	CURRENT DATE
26	26-1	Re-Edición	08/12/2014
	26-2	Re-Edición	08/12/2014
27	27-1	Re-Edición	08/12/2014
	27-2	Revisión 09	26/02/2021
28	28-1	Revisión 07	04/07/2017
	28-2	Re-Edición	08/12/2014
	28-3	Re-Edición	08/12/2014
	28-4	Re-Edición	08/12/2014
	28-5	Re-Edición	08/12/2014
29	29-1	Re-Edición	08/12/2014
	29-2	Re-Edición	08/12/2014
30	30-1	Re-Edición	08/12/2014
	30-2	Revisión 09	26/02/2021
	30-3	Revisión 09	26/02/2021
31	31-1	Revisión 03	01/09/2015
	31-2	Revisión 01	20/04/2014
32	32-1	Re-Edición	08/12/2014
	32-2	Re-Edición	08/12/2014
33	33-1	Re-Edición	08/12/2014
	33-2	Revisión 09	26/02/2021
	33-3	Revisión 07	04/07/2017
34	34-1	Revisión 03	01/09/2015
	34-2	Re-Edición	08/12/2014
	34-3	Re-Edición	08/12/2014
	34-4	Re-Edición	08/12/2014
	34-5	Revisión 07	04/07/2018
	34-6	Re-Edición	08/12/2014
	34-7	Revisión 09	26/02/2021
	34-8	Revisión 09	26/02/2021
	34-9	Revisión 09	26/02/2021
	34-10	Revisión 09	26/02/2021
35	35-1	Revisión 03	01/09/2015
	35-2	Revisión 09	26/02/2021
36	36-1	Re-Edición	08/12/2014
	36-2	Re-Edición	08/12/2014
38	38-1	Revisión 09	26/02/2021
45	45-1	Revisión 09	26/02/2021
46	46-1	Re-Edición	08/12/2014
49	49-1	Re-Edición	08/12/2014
52	52-1	Re-Edición	08/12/2014
56	56-1	Re-Edición	08/12/2014
73	73-1	Re-Edición	08/12/2014
	73-2	Re-Edición	08/12/2014

SYSTEM	PAGE NO.	REV. NO.	CURRENT DATE
74	74-1	Re-Edición	08/12/2014
76	76-1	Re-Edición	08/12/2014
77	77-1	Re-Edición	08/12/2014
78	78-1	Re-Edición	08/12/2014
79	79-1	Re-Edición	08/12/2014
80	80-1	Re-Edición	08/12/2014
Guideline (M) & (O)	M & O-1	Revisión 09	26/02/2021
	M & O-2	Re-Edición	08/12/2014
	M & O-3	Re-Edición	08/12/2014
	M & O-4	Re-Edición	08/12/2014
	M & O-5	Re-Edición	08/12/2014
	M & O-6	Revisión 09	08/12/2014
	M & O-7	Re-Edición	08/12/2014
	M & O-8	Revisión 09	26/02/2021
	M & O-9	Re-Edición	08/12/2014
	M & O-10	Re-Edición	08/12/2014
	M & O-11	Re-Edición	08/12/2014
	M & O-12	Re-Edición	08/12/2014
	M & O-13	Revisión 09	26/02/2021
	M & O-14	Re-Edición	08/12/2014
	M & O-15	Re-Edición	08/12/2014
	M & O-16	Revisión 09	26/02/2021
	M & O-17	Re-Edición	08/12/2014
	M & O-18	Revisión 09	26/02/2021
	M & O-19	Revisión 09	26/02/2021
	M & O-20	Revisión 09	26/02/2021
	M & O-21	Re-Edición	08/12/2014
	M & O-22	Re-Edición	08/12/2014
	M & O-23	Revision 04	28/01/2020
	M & O-24	Revision 09	26/02/2021
	M & O-25	Revision 04	28/01/2020
	M & O-26	Revision 04	28/01/2020
	M & O-27	Revision 04	28/01/2020
	M & O-28	Re-Edición	08/12/2014
	M & O-29	Re-Edición	08/12/2014
	M & O-30	Re-Edición	08/12/2014
	M & O-31	Re-Edición	08/12/2014
	M & O-32	Revision 09	26/02/2021
	M & O-33	Revision 09	26/02/2021
	M & O-34	Revision 04	28/01/2020
	M & O-35	Revision 04	28/01/2020
	M & O-36	Revision 04	28/01/2020
	M & O-37	Revision 04	28/01/2020

SYSTEM	PAGE NO.	REV. NO.	CURRENT DATE
Guideline (M) & (O)	M & O-38	Revision 04	28/01/2020
	M & O-39	Revision 04	28/01/2020
	M & O-40	Revision 04	28/01/2020
	M & O-41	Revision 04	28/01/2020
	M & O-42	Re-Edición	08/12/2014
	M & O-43	Re-Edición	08/12/2014
	M & O-44	Revision 09	26/02/2021
	M & O-45	Revision 09	26/02/2021
	M & O-46	Re-Edición	08/12/2014
	M & O-47	Revision 04	28/01/2020
	M & O-48	Revision 04	28/01/2020
	M & O-49	Revision 04	28/01/2020
	M & O-50	Revision 04	28/01/2020
	M & O-51	Revision 04	28/01/2020
	M & O-52	Re-Edición	08/12/2014
	M & O-53	Re-Edición	08/12/2014
	M & O-54	Re-Edición	08/12/2014
	M & O-55	Re-Edición	08/12/2014
	M & O-56	Re-Edición	08/12/2014
	M & O-57	Re-Edición	08/12/2014
	M & O-58	Re-Edición	08/12/2014
	M & O-59	Re-Edición	08/12/2014
	M & O-60	Re-Edición	08/12/2014
	M & O-61	Re-Edición	08/12/2014
	M & O-62	Re-Edición	08/12/2014
	M & O-63	Re-Edición	08/12/2014
	M & O-64	Re-Edición	08/12/2014
	M & O-65	Re-Edición	08/12/2014
	M & O-66	Re-Edición	08/12/2014
	M & O-67	Re-Edición	08/12/2014
	M & O-68	Revision 04	28/01/2020
	M & O-69	Revision 04	28/01/2020
	M & O-70	Revision 04	28/01/2020
	M & O-71	Revision 04	28/01/2020
	M & O-72	Revision 04	28/01/2020
	M & O-73	Revision 04	28/01/2020
	M & O-74	Revision 04	28/01/2020
	M & O-75	Revision 09	26/02/2021
	M & O-76	Revision 04	28/01/2020
	M & O-77	Revision 04	28/01/2020
	M & O-78	Re-Edición	08/12/2014
M & O-79	Re-Edición	08/12/2014	
M & O-80	Re-Edición	08/12/2014	
M & O-81	Re-Edición	08/12/2014	

SYSTEM	PAGE NO.	REV. NO.	CURRENT DATE
Guideline (M) & (O)	M & O-82	Re-Edición	08/12/2014
	M & O-83	Revision 04	28/01/2020
	M & O-84	Revision 04	28/01/2020
	M & O-85	Revision 04	28/01/2020
	M & O-86	Revision 04	28/01/2020
	M & O-87	Revision 04	28/01/2020
	M & O-88	Re-Edición	08/12/2014
	M & O-89	Revision 04	28/01/2020
	M & O-90	Revision 04	28/01/2020
	M & O-91	Revision 04	28/01/2020
	M & O-92	Revision 04	28/01/2020
	M & O-93	Revision 04	28/01/2020
	M & O-94	Revision 04	28/01/2020
	M & O-95	Revision 09	26/02/2021
	M & O-96	Re-Edición	08/12/2014
	M & O-97	Revision 04	28/01/2020
	M & O-98	Revision 07	04/07/2017
	M & O-99	Revision 09	26/02/2021
	M & O-100	Revision 07	04/07/2017
	M & O-101	Revision 07	04/07/2017
	M & O-102	Revision 07	04/07/2017
	M & O-103	Revision 07	04/07/2017
	M & O-104	Revision 04	28/01/2020
	M & O-105	Revision 09	26/02/2021
	M & O-106	Revision 09	26/02/2021
	M & O-107	Revision 04	28/01/2020
	M & O-108	Revision 04	28/01/2020
	M & O-109	Revision 04	28/01/2020
	M & O-110	Re-Edición	08/12/2014
	M & O-111	Revision 04	28/01/2020
	M & O-112	Revision 04	28/01/2020
	M & O-113	Re-Edición	08/12/2014
	M & O-114	Re-Edición	08/12/2014
M & O-115	Revision 09	26/02/2021	
M & O-116	Revision 09	26/02/2021	
M & O-117	Re-Edición	08/12/2014	
M & O-118	Re-Edición	08/12/2014	
M & O-119	Re-Edición	08/12/2014	
M & O-120	Re-Edición	08/12/2014	
M & O-121	Re-Edición	08/12/2014	
M & O-122	Revision 04	28/01/2020	
M & O-123	Revision 04	28/01/2020	

SYSTEM	PAGE NO.	REV. NO.	CURRENT DATE	
Guideline (M) & (O)	M & O-124	Revision 04	28/01/2020	
	M & O-125	Re-Edición	08/12/2014	
	M & O-126	Re-Edición	08/12/2014	
	M & O-127	Re-Edición	08/12/2014	
	M & O-128	Re-Edición	08/12/2014	
	M & O-129	Re-Edición	08/12/2014	
	M & O-130	Re-Edición	08/12/2014	
	M & O-131	Re-Edición	08/12/2014	
	M & O-132	Revision 09	26/02/2021	
	M & O-133	Re-Edición	08/12/2014	
	M & O-134	Re-Edición	08/12/2014	
	M & O-135	Re-Edición	08/12/2014	
	Configuration Desviation List	CDL-(1-8)	Re-Edición	08/12/2014
		CDL-9	Revisión 07	04/07/2017
		CDL-(10-18)	Re-Edición	08/12/2014
CDL-19		Revision 04	28/01/2020	
Nonessential Equipment List	CDL-(20-48)	Re-Edición	08/12/2014	
	NEF-(1-3)	Revisión 06	03/09/2016	
	NEF-4	Revision 09	26/02/2021	
ANEXO	NEF-(5-12)	Revisión 06	03/09/2016	
	ANEX (1-2)	Revisión 07	04/07/2017	

APPLICABILITY

This Minimum Equipment List (MEL) is applicable to the EMB-145 models. The procedures contained in this MEL have been developed by **LINK CONEXIÓN AÉREA, S.A. DE C.V.** for use during the operation of their EMB-145 models.

MARCA	MODELO	NÚMERO DE SERIE	MATRÍCULA
EMBRAER	145LR	145507	XA-BPK
EMBRAER	145LR	145568	XA-MFH
EMBRAER	145LR	145481	XA-RHF
EMBRAER	145LR	145063	XA-NFP
EMBRAER	145LR	145067	XA-SFH
EMBRAER	145LR	145075	XA-JFH
EMBRAER	145LR	145080	XA-MAF
EMBRAER	145LR	145078	XA-AFH
EMBRAER	145LR	145138	XA-PFL
EMBRAER	145LR	145071	XA-EFH
EMBRAER	145LR	145241	XA-IFP



MINIMUM EQUIPMENT LIST

EMBRAER 145LR

DEFINITIONS

1. System Definitions.

System numbers are based on the Air Transport Association (ATA) Specification Number 100 and items are numbered sequentially.

"Item" (Column 1) means the equipment, system, component, or function listed in the "Item" column.

"Number Installed" (Column 2) is the number (quantity) of items normally installed in the aircraft. This number represents the aircraft configuration considered in developing this MMEL. Should the number be a variable (e.g., passenger cabin items) a number is not required.

"Number Required for Dispatch" (Column 3) is the minimum number (quantity) of items required for operation provided the conditions specified in Column 4 are met.

NOTE: Where the MMEL shows a variable number required for dispatch, the MEL must reflect the actual number required for dispatch or an alternate means of configuration control approved by the Administrator.

"Remarks or Exceptions" (Column 4) in this column includes a statement either prohibiting or permitting operation with a specific number of items inoperative, provisos (conditions and limitations) for such operation, and appropriate notes.

A vertical bar (change bar) in the margin indicates a change, addition or deletion in the adjacent text for the current revision of that page only. The change bar is dropped at the next revision of that page.

2. "Airplane Flight Manual" (AFM) is the document required for type certification and approved by the responsible FAA Aircraft Certification Office. The FAA approved AFM for the specific aircraft is listed on the applicable Type Certificate Data Sheet.

3. "Airplane Operations Manual" (AOM) is the document required for type certification and approved by the responsible FAA Aircraft Certification Office. The FAA approved AOM for the specific aircraft is listed on the applicable Type Certificate Data Sheet.

4. "Automatic Dependent Surveillance Broadcast" (ADS-B) is a surveillance technology in which an aircraft determines its position via satellite navigation and periodically broadcasts it, enabling it to be tracked

5. "As required by MCAA (Mexican Civil Aviation Authority)" means that the listed item is subject to certain provisions (restrictive or permissive) expressed in the Ley de Aviación Civil, Reglamento de la Ley de Aviación Civil, operating rules. The number of items required by the AFAC must be operative. When the listed item is not required by AFAC it may be inoperative for the time specified by repair category.

6. Each inoperative item must be placarded to inform and remind the crewmembers and maintenance personnel of the equipment condition.



MINIMUM EQUIPMENT LIST

EMBRAER 145LR

NOTE: To the extent practical, placards should be located adjacent to the control or indicator for the item affected; however, unless otherwise specified, placard wording and location will be determined by the operator.

7. "Deleted" in the remarks column after a sequence item indicates that the item was previously listed but is now required to be operative if installed in the aircraft.

8. "NORMA OFICIAL MEXICANA" (NOM) means the applicable portions of Mexican Civil Aviation Authority Regulation.

9. "Flight Day" means a 24-hour period (from midnight to midnight) local time during which at least one flight is initiated for the affected aircraft.

10. "Icing Conditions" means an atmospheric environment that may cause ice to form on the aircraft or in the engine(s).

11. Alphabetical symbol in Column 4 indicates a proviso (condition or limitation) that must be complied with for operation with the listed item inoperative.

12. "Inoperative" means a system and/or component malfunction to the extent that it does not accomplish its intended purpose and/or is not consistently functioning normally within its approved operating limit(s) or tolerance(s).

13. "Notes:" in Column 4 provides additional information for crewmember or maintenance consideration. Notes are used to identify applicable material which is intended to assist with compliance, but do not relieve the operator of the responsibility for compliance with all applicable requirements. Notes are not a part of the provisos.

14. Inoperative components of an inoperative system: Inoperative items which are components of a system which is inoperative are usually considered components directly associated with and having no other function than to support that system. Warning/caution systems associated with the inoperative system must be operative unless relief is specifically authorized per the MMEL).

15. "(M)" symbol indicates a requirement for a specific maintenance procedure which must be accomplished prior to operation with the listed item inoperative. Normally these procedures are accomplished by maintenance personnel; however, other personnel may be qualified and authorized to perform certain functions. Procedures requiring specialized knowledge or skill, or requiring the use of tools or test equipment should be accomplished by maintenance personnel. The satisfactory accomplishment of all maintenance procedures, regardless of who performs them, is the responsibility of the operator. Appropriate procedures are required to be published as part of the operator's manual or MEL.

16. "(O)" symbol indicates a requirement for a specific operations procedure which must be accomplished in planning for and/or operating with the listed item inoperative. Normally these procedures are accomplished by the flight crew; however, other personnel may be qualified and authorized to perform certain functions. The satisfactory accomplishment of all procedures, regardless of who performs them,



MINIMUM EQUIPMENT LIST

EMBRAER 145LR

is the responsibility of the operator. Appropriate procedures are required to be published as a part of the operator's manual or MEL.

NOTE: The (M) and (O) symbols are required in the operator's MEL unless otherwise authorized by the Administrator.

17. "Deactivated" and "Secured" means that the specified component must be put into an acceptable condition for safe flight. An acceptable method of securing or deactivating will be established by the operator.

18. "Visual Flight Rules" (VFR) is as defined in Ley de Aviación Civil, Reglamento de la Ley de Aviación Civil. This precludes a pilot from filing an Instrument Flight Rules (IFR) flight plan.

19. "Visual Meteorological Conditions" (VMC) means the atmospheric environment is such that would allow a flight to proceed under the visual flight rules applicable to the flight. This does not preclude operating under Instrument Flight Rules.

20. "Visible Moisture" means an atmospheric environment containing water in any form that can be seen in natural or artificial light; for example, clouds, fog, rain, sleet, hail, or snow.

21. "Passenger Convenience Items" means those items related to passenger convenience, comfort or entertainment such as, but not limited to, galley equipment, movie equipment, ash trays, stereo equipment, overhead reading lamps, etc.

22. Repair Intervals: All users of a MEL approved under NOM-018-SCT3-2012, NOM-008-SCT3-2002 y NOM-002-SCT3-2001 effect repairs of inoperative systems or components, deferred in accordance with the MEL, at or prior to the repair times established by the following letter designators:

Category A. Items in this category shall be repaired within the time interval specified in the remarks column of the operator's approved MEL.

Category B. Items in this category shall be repaired within three (3) consecutive calendar days (72 hours, excluding the day the malfunction was recorded in the aircraft maintenance record/logbook. For example, if it were recorded at 10 a.m. on January 26th, the three-day interval would begin at midnight the 26th and end at midnight the 29th.

Category C. Items in this category shall be repaired within Ten (10) consecutive calendar days (240 hours), excluding the day the malfunction was recorded in the aircraft maintenance record/logbook. For example, if it were recorded at 10 a.m. on January 26th, the 10-day interval would begin at midnight the 26th and end at midnight February 5th.

Category D. Items in this category shall be repaired within one hundred and twenty (120) consecutive calendar days (2880 hours), excluding the day the malfunction was recorded in the aircraft maintenance log and/or record.



MINIMUM EQUIPMENT LIST

EMBRAER 145LR

The letter designators are inserted adjacent to Column 2.

23. Electronic fault alerting system – General - New generation aircraft display system fault indications to the flight crew by use of computerized display systems. Each aircraft manufacturer has incorporated individual design philosophies in determining the data that would be represented. The following are customized definitions (specific to each manufacturer) to help determine the level of messages affecting the aircraft's dispatch status. When preparing the MEL document, operators are to select the proper Definition No. 21 for their aircraft, if appropriate System conditions that result only in a maintenance level message, i.e. no correlation with a higher level EICAS message, do not affect dispatch and do not require action other than as addressed within an operator's standard maintenance program.

EMBRAER (EMB-145).

The EMB-145 is equipped with an Engine Indicating and Crew Alerting System (EICAS) that provides three different message levels: WARNING, CAUTION, and ADVISORY. Other failures may be presented only to the maintenance personnel on the Multi Function Display (MFD) maintenance pages or through the download of the Central Maintenance Computer (CMC). System conditions that result only in a maintenance level message, i.e. no correlation with a higher level EICAS message, do not affect dispatch and do not require action other than as addressed within an aircraft operator's standard maintenance program.

24. "Administrative control item" means an item listed by the operator in the MEL for tracking and informational purposes. It may be added to an operator's MEL by approval of the Principal Operations Inspector provided no relief is granted, or provided conditions and limitations are contained in an approved document (i.e. Structural Repair Manual, airworthiness directive, etc.). If relief other than that granted by an approved document is sought for an administrative control item, a request must be submitted to the Administrator.

25. "Excess Items" means those items that have been installed that are redundant to the requirements.

26. "Day of Discovery" is the calendar day an equipment/instrument malfunction was recorded in the aircraft maintenance logbook and or record. This day is excluded from the calendar days or flight days specified in the MMEL for the repair of an inoperative item of equipment. This provision is applicable to all MMEL items, i.e., categories "A, B, C, and D."

27. "NONESSENTIAL EQUIPMENT AND FURNISHINGS (NEF)" NEF are those items installed on the airplane as part of the original type certification, supplemental type certificate, or other form of alteration that have no effect on the safe operation of flight and would not be required by the applicable certification rules or operational rules. They are those items that, if inoperative, damaged, or missing, have no effect on the airplane's ability to be operated safely under all operational conditions.



MINIMUM EQUIPMENT LIST

EMBRAER 145LR

PREAMBLE

The following is applicable for authorized certificate holders operating under Ley de Aviación Civil require that all equipment installed on an aircraft in compliance with the Airworthiness Standards and the Operating rules must be operative. However, the Rules also permit the publication of Minimum Equipment List (MEL) where compliance with certain equipment requirements is not necessary in the interest of safety under all operating conditions. Experience has shown that with that various levels of redundancy designed into aircraft, operation of every system or installed component may not be necessary when the remaining operative equipment provide an acceptable level of safety. This Minimum Equipment List (MEL) is developed by **LINK CONEXIÓN AÉREA, S.A. DE C.V.**, to improve aircraft utilization and thereby provide more convenient and economic air transportation for the public. The authority approved MEL; includes those items of equipment related to Airworthiness and Operating regulations and other items of equipment which the AFAC finds may be inoperative and yet maintain an acceptable level of safety by appropriate conditions and limitations; it does not contain obviously required items such as wings, flaps, and rudders. The MMEL is the basis for development of individual operator operator MELs which take into consideration the operator's particular aircraft equipment configuration and operational conditions. **LINK CONEXIÓN AÉREA, S.A. DE C.V.**, MELs, for administrative control, may include items not contained in the MMEL; however, relief for administrative control items must be approved by the Administrator. **LINK CONEXIÓN AÉREA, S.A. DE C.V.**, MEL may differ in format from the MMEL, but cannot be less restrictive than the MMEL. The individual operator's MEL, when approved and authorized, permits operation of the aircraft with inoperative equipment.

Equipment no required by the operation being conducted and equipment in excess of Authorities are included in the MEL with appropriate conditions and limitations. The MEL must not deviate from the Aircraft Flight Manual Limitations, Emergency Procedures or with Airworthiness Directives. It is important to remember that all equipment related to the airworthiness and the operating regulations of the aircraft not listed on the MEL must be operative. Suitable conditions and limitations in the form of placards, maintenance procedures, crew operating procedures and other restrictions as necessary are specified in the MEL to ensure that an acceptable level of safety is maintained.

Complementing the MEL, the company edit the Nonessential Equipment and Furnishings List which contains the non-essential components, and furniture. These components may be inoperative, damaged, or missing as long as the component is deferred according with NEF list located in the NEF section of this MEL.

The MEL is intended to permit operation with inoperative items of equipment for a period of time until repairs can be accomplished. It is important that repairs be accomplished at the earliest opportunity. In order to maintain an acceptable level of safety and reliability the MEL establishes limitations on the duration of and conditions for operation with inoperative equipment. The MEL provides for release of the aircraft for flight with inoperative equipment. When an item of equipment is discovered to be inoperative, it is reporting by making an entry in the Aircraft Maintenance Record/Logbook as prescribed by Authorities. The item is the either repaired or may be deferred per the MEL or other approved means acceptable to the AFAC prior to further operation. MEL conditions and limitations do not relieve from determining that the aircraft is in condition for safe operation with items of equipment inoperative.



MINIMUM EQUIPMENT LIST

EMBRAER 145LR

When these requirements are met, an Airworthiness Release, Aircraft Maintenance Record/Logbook entry, or other approved documentation is issued as prescribed by AFAC. Such documentation is required prior to operation with any item of equipment inoperative.

LINK CONEXIÓN AÉREA, S.A. DE C.V., Is responsible for exercising the necessary operational control to ensure that an acceptable level of safety is maintained. When operating with multiple inoperative items the interrelationships between those items and the effect on aircraft operation and crew workload will be considered.

LINK CONEXIÓN AÉREA, S.A. DE C.V., is to establish a controlled and sound repair program including the parts, personnel, facilities procedures and schedules to ensure timely repair.

WHEN USING THIS MEL, COMPLIANCE WITH THE STATED INTENT OF THE PREAMBLE DEFINITIONS, AND THE CONDITIONS AND LIMITATIONS IS REQUIRED.

THE SECTION CDL "CONFIGURATION DEVIATION LIST" CAN BE FOUND ON SECTION OF GUIDELINES (M) & (O) PROCEDURES.

RVSM

En México, la SCT (AFAC) ha emitido el 23 de marzo de 2009 la NOM-091-SCT3-2004, que establece las operaciones en el espacio aéreo mexicano con Separación Vertical Mínima Reducida (RVSM).

El espacio aéreo mexicano RVSM solo puede ser operado con aeronaves que cuenten con la aprobación operacional RVSM.

El equipamiento mínimo para realizar operaciones RVSM se compone de:

A. Dos sistemas primarios independientes de medición de altitud. Cada Sistema debe de estar constituido:

- Fuente o Sistema estático de acoplamiento cruzado con protección contra hielo si se esta en zonas expuestas con formación de hielo
- Un equipo de medición de presión estática.
- Un equipo que proporcione una señal codificada digitalmente correspondiente a la latitud barométrica presentada para la generación automática de informes de altitud.
- Corrección del error de la toma de estática (SSEC).
- Señales referenciadas a la altitud seleccionada por el piloto para el control y avisos automáticos.

B. Un Sistema de alerta de altitud.

C. Un Sistema automático de control de altitud.

D. Un transpondedor de radar secundario dotado de un Sistema de reporte de altitud.

Los niveles de Crucero en el espacio RVSM van desde FL290 - FL410.

EICAS MESSAGE LIST

The main purpose of the EICAS Message List is to provide a quick means to cross-reference an EICAS Message with the possible associated MMEL/MEL item. This EICAS Message List is intended to assist operators in defining if the condition presented by the message is a deferrable one or not.

It is not the intent of this list to replace or disregard proper troubleshooting of the associated EICAS Messages.

Whenever an EICAS Message is displayed, its cause must be investigated by using the appropriate means, such as the Fault Isolation Manual (FIM) or associated maintenance procedures. Only after the proper identification of the failed component that an MMEL/MEL relief may be used.

The list presents all EICAS Messages that may be related to a system failure. Thus, EICAS Messages which has only status information is not contained in this list.

This list presents the EICAS Messages according to the following classification:

1. **TYPE:** Indicates whether the message is classified as Warning (W), Caution (C) or Advisory (A);
2. **MESSAGE:** Provide the EICAS Messages on alphabetical order;
3. **POSSIBLE FAILED COMPONENTS:** Among all possible failure causes related to the EICAS message, only those for which a relief is predicted upon the MMEL/MEL application is listed. For all remaining failure modes for which no MMEL/MEL relief is granted, a dash sign (“-”) is used;
4. **REFER TO:** Indicates the MMEL/MEL item number associated to the possible failed components, if applicable. When no relief is granted in the MMEL/MEL, the “NO DISP” inscription identifies a no dispatch condition. The “not applicable” (N/A) indicates that the EICAS message is not related to a system failure condition.
5. **REMARKS:** Presents further information on the cause of the EICAS message, whether it is an actual message or a spurious one. The spurious message is identified by a “false” inscription and means that the failure condition displayed by the EICAS message is not present, usually associated to a failure of a monitoring function.



MINIMUM EQUIPMENT LIST

EMBRAER 145LR

TYPE	MESSAGE	POSSIBLE FAILED COMPONENTS	REFER TO	REMARKS
A	AHRS 1(2) NO PPOS	-	N/A	Present position not entered
A	AHRS 1(2) ON BATT	-	NO DISP	-
C	AHRS 1(2) OVERHEAT	-	NO DISP	-
A	AIII NOT AVAIL	-	N/A	-
C	AIL SYS 1 INOP	-	NO DISP	-
C	AIL SYS 2 INOP	-	NO DISP	-
C	AOA 1(2) HEAT INOP	AOA Heater Sensor	MEL 30-32-01	-
C	AP AIL MISTRIM	Roll Trim Actuator	NO DISP	-
		Autopilot	MEL 22-10-00	-
C	AP ELEV MISTRIM	Elevator Actuator	NO DISP	-
		Autopilot	MEL 22-10-00	-
C	APU BLD VLV FAIL	APU Bleed System	MEL 36-12-01	-
C	APU CNTOR CLSD	APU Starter Contactor	MEL 24-34-01	-
C	APU EXTBTL INOP	APU EXTBTL INOP Message	MEL 26-22-00	Actual Caution
		APU EXTBTL INOP Message	MEL 26-22-01	False Caution
C	APU FAIL	APU	MEL 49-00-00	Actual Caution
		APU FAIL message	MEL 49-70-03	False Caution
C	APU FIREDET FAIL	APU Fire Detection System	MEL 26-12-00	-
C	APU FUEL LO PRESS	APU System	MEL 49-00-00	-
		APU Fuel Low Press Switch	MEL 28-45-02	-
		Other failures	NO DISP	-

TYPE	MESSAGE	POSSIBLE FAILED COMPONENTS	REFER TO	REMARKS
C	APU FUEL SOV INOP	APU Shut-off Valve	MEL 28-22-01	-
C	APU GEN OFF BUS	APU Starter Generator	MEL 24-34-01	-
C	APU GEN OVLD	APU Starter Generator	MEL 24-34-01	-
C	APU OIL HI TEMP	APU Oil System	MEL 49-70-02	False Caution
		APU	MEL 49-00-00	Actual Caution
C	APU OIL LO PRESS	APU Oil System	MEL 49-70-01	False Caution
		APU	MEL 49-00-00	Actual Caution
W	ATTCS FAIL	A, A1, A1/1 and A3	73-22-02	-
		Other engines	NO DISP	-
C	AURAL WARN FAIL	-	NO DISP	-
C	AUTO TRIM FAIL	Other failures	NO DISP	-
		Autopilot	MEL 22-10-00	-
W	AUTOPILOT FAIL	Autopilot	MEL 22-10-00	-
C	BAGG EXTBTL INOP	Baggage Compartment Fire Extinguisher System	MEL 26-23-00	-
C	BAGGAGE DOOR OPN	Door Warning Microswitches	MEL 52-70-00	False Warning
		Door Actuating and Locking Mechanism	NO DISP	Actual Warning
C	BATT 1(2) OFF BUS	-	NO DISP	-
W	BATT 1(2) OVTEMP	-	NO DISP	-
C	BKUP BATT OFF BUS	-	NO DISP	-
W	BLD 1(2) LEAK	Engine Bleed Systems	MEL 36-11-05	-
		Other failures	NO DISP	-



MINIMUM EQUIPMENT LIST

EMBRAER 145LR

TYPE	MESSAGE	POSSIBLE FAILED COMPONENTS	REFER TO	REMARKS
C	BLD 1(2) LOW TEMP	Engine Bleed Systems	MEL 36-11-05	-
		Other failures	NO DISP	-
W	BLD 1(2) OVTEMP	Engine Bleed Systems	MEL 36-11-05	-
		Other failures	NO DISP	-
A	BLD 1(2) VLV CLSD	Engine Bleed Valve	MEL 36-11-05	-
		Other failures	NO DISP	-
C	BLD 1(2) VLV FAIL	Engine Bleed Valve	MEL 36-11-05	-
		Other failures	NO DISP	-
W	BLD APU LEAK	APU Bleed System	MEL 36-12-01	Actual Warning
		BLD APU LEAK message	MEL 36-20-00	False Warning
C	BRAKE DEGRADED	Brake Pressure Transducer	MEL 32-41-08	-
		Other failures	NO DISP	-
C	BRAKE OVERHEAT	-	NO DISP	-
C	BRK INBD INOP	-	NO DISP	-
C	BRK OUTBD INOP	-	NO DISP	-
W	CHECK ACFT LOAD	CHECK ACFT LOAD message	MEL 28-45-06	False Warning
C	CHECK IC 1 SW	-	NO DISP	-
C	CHECK IC 2 SW	-	NO DISP	-
C	CHECK PFD 1 (2)	Main Panel Display	MEL 34-22-01	Perform Display swap
		Other failures	NO DISP	-
A	CHECKLST MISMATCH	-	NO DISP	-
C	CHK IC CONFIG	-	NO DISP	-
A	CONFIG MISMATCH	-	NO DISP	-
C	CROSS BLD FAIL	-	NO DISP	-

TYPE	MESSAGE	POSSIBLE FAILED COMPONENTS	REFER TO	REMARKS
C	CROSS BLD SW OFF	-	N/A	Cross Bleed is OFF
		Cross Bleed Switch	NO DISP	-
C	DAU 1 A FAIL	-	NO DISP	-
A	DAU 1 B FAIL	-	NO DISP	-
C	DAU 1 ENG MISCOMP	-	NO DISP	-
A	DAU 1 REVERSION	-	NO DISP	-
C	DAU 1 SYS MISCOMP	-	NO DISP	-
C	DAU 1 WRN MISCOMP	-	NO DISP	-
C	DAU 2 A FAIL	-	NO DISP	-
A	DAU 2 B FAIL	-	NO DISP	-
C	DAU 2 ENG MISCOMP	-	NO DISP	-
A	DAU 2 REVERSION	-	NO DISP	-
C	DAU 2 SYS MISCOMP	-	NO DISP	-
C	DAU 2 WRN MISCOMP	-	NO DISP	-
C	DAU AC ID MISCMP	-	NO DISP	-
C	DC BUS 1(2) OFF	-	NO DISP	-
C	DFDR FAIL	Failure of Flight Data Recorder (FDR)	MEL 31-30-01	-
		Other failures	NO DISP	-
A	DU 1(2,3,4,5) FAN FAIL	Display Unit Fan	MEL 34-22-01	DU is deactivated
A	DU 1(2,3,4,5) OVHT	Display Unit	MEL 34-22-01	DU is deactivated
A	E1 HYD PUMP FAIL	Pressure Switch of EDP	MEL 29-10-19	-
		Engine Driven Pump	NO DISP	-
C	E1(2) NO DISP	-	NO DISP	-
C	E1(2) A/ICE FAIL	ENG 1 A/ICE System	MEL 30-21-00	-
		ENG 1 A/ICE Valve	MEL 30-21-01	-

TYPE	MESSAGE	POSSIBLE FAILED COMPONENTS	REFER TO	REMARKS
C	E1(2) ATS SOV OPN	Starter Control Valve	MEL 80-10-02	-
		Other failures	NO DISP	-
W	E1(2) ATTCS NO MRGN	-	NO DISP	-
C	E1(2) CTL FAIL	-	NO DISP	-
C	E1(2) EXCEEDANCE	-	NO DISP	-
C	E1(2) EXBTBLA(B) INOP	E1(2) EXBTBLA(B) INOP Message	MEL 26-21-02	False Caution
		Other failures	NO DISP	-
C	E1(2) FIREDET FAIL	-	NO DISP	-
C	E1(2) FPMU NO DISP	-	NO DISP	-
A	E1(2) FUEL IMP BYP	Electrical/Mechanical Impending Bypass Indicator	MEL 73-33-01	False Advisory
		Fuel Imp Bypass	MEL 73-33-02	Actual Advisory
C	E1(2) FUEL LO PRESS	Wing Tank Electric Fuel Booster Pumps	MEL 28-21-01	Actual Caution
		E1(2) FUEL LO PRESS message	MEL 28-45-01	False Caution
C	E1(2) FUEL LO TEMP	-	NO DISP	-
C	E1(2) FUEL SOV INOP	-	NO DISP	-
A	E1(2) IDL STP FAIL	Engine Idle Lock Solenoid	MEL 78-34-05	-
W	E1(2) LOW N1	-	NO DISP	-
C	E1(2) NO DISP	FADEC fault	MEL 73-22-01	-
A	E1(2) OIL IMP BYP	Oil Filter Element	MEL 73-35-02	Actual Advisory
		Oil-Filter Impending-Bypass Switch	MEL 73-35-01	False Advisory
W	E1(2) OIL LOW PRESS	Low-Oil-Pressure Sensor (Switch)	MEL 79-32-01	False Warning
		Actual Low Oil Press	NO DISP	-
A	E1(2) SHORT DISP	FADEC fault	MEL 73-22-01	-
A	E1(2) HYD PUMP FAIL	-	NO DISP	-

TYPE	MESSAGE	POSSIBLE FAILED COMPONENTS	REFER TO	REMARKS
C	ELEC EMERG ABNORMAL	-	NO DISP	-
W	ELEC ESS XFR FAIL	-	NO DISP	-
C	ELEKBAY OVTEMP	-	NO DISP	-
C	EMERG EXIT OPN	Hatch Microswitches	MEL 52-70-00	False Caution
		Hatch Locking Mechanism	NO DISP	Actual Caution
C	EMERG LT NOT ARMD	-	N/A	-
C	EMRG BRK LO PRES	Accumulator Low Pressure Switch	MEL 32-44-05	-
		Other failures	NO DISP	-
C	ENG 1(2) REV DISAGREE	Thrust Reverser System	MEL 78-30-00	-
C	ENG 1(2) REV FAIL	Other failures	MEL 78-30-00	-
		FADEC TR Interface	NO DISP	-
A	ENG A/ICE OVERPRES	ENG 1 A/ICE System	MEL 30-21-00	-
		ENG 1 A/ICE Valve	MEL 30-21-01	-
W	ENG ATTCS FAIL	ATTCS	MEL 73-22-02	-
C	ENG NO TO DATA	FADEC fault	MEL 73-22-01	-
C	ENG REF A/I DISAG	-	N/A	-
W	ENG1 (2) OUT	-	NO DISP	-
C	ENG1(2) OUT	-	NO DISP	-
C	ENG1(2) TLA FAIL	-	NO DISP	-
C	ESS BUS 1(2) OFF	-	NO DISP	-
C	FADEC ID NO DISP	-	NO DISP	-



MINIMUM EQUIPMENT LIST

EMBRAER 145LR

TYPE	MESSAGE	POSSIBLE FAILED COMPONENTS	REFER TO	REMARKS
A	FDAU FAIL	Flight Data Acquisition Unit/Auxiliary Flight Data Acquisition and Management Unit (AFDAU/AFDAMU)	MEL 31-30-00	-
C	FLAP FAIL	-	NO DISP	-
A	FLAP LOW SPEED	Flap Channel	MEL 27-53-00	-
W	FUEL LO LEVEL	FUEL LO LEVEL message	MEL 28-44-00	False Warning
C	FUEL TK VENT OPEN	FUEL TK VENT OPEN message	MEL 28-14-00	False Caution
		Forward Auxiliary Tank Vent Valve	MEL 28-45-10	Actual Caution
		Aft Auxiliary Tank Vent Valve	MEL 28-45-16	Actual Caution
		Ventral Tank Vent Valve	MEL 28-45-17	Actual Caution
C	FUEL XFEED FAIL	-	NO DISP	-
C	FUEL XFER 1(2) INOP	FUEL XFER 1(2) message	MEL 28-45-12	False Caution
W	FUEL XFER CRITICAL	FUEL XFER CRITICAL message	MEL 28-45-13	False Warning
C	FUEL XFR VTR INOP	FUEL XFR VTR INOP message	MEL 28-45-15	False Caution
C	FUELING DOOR OPN	Panel Switch Electrical Circuit	MEL 52-70-00	False Caution
		Panel Locking Mechanism	NO DISP	Actual Caution
C	FUSELAGE FUEL IMB	FUSELAGE FUEL IMB message	MEL 28-45-05	False Caution
A	GEN 1(2,3,4) BRG FAIL	Engine Driven Generator Bearings	MEL 24-31-02	-
		Engine Driven Generator	MEL 24-31-01	-

TYPE	MESSAGE	POSSIBLE FAILED COMPONENTS	REFER TO	REMARKS
C	GEN 1(2,3,4) OFF BUS	Engine Driven Generator	MEL 24-31-01	-
C	GEN 1(2,3,4) OVLD	Engine Driven Generator	MEL 24-31-01	-
		APU Starter Generator	MEL 24-34-01	-
C	GPWS INOP	GPWS/Windshear Computer	MEL 34-41-00	-
C	HGS FAIL	HGS	MEL 34-25-00	-
C	HS VLV 1(2) FAIL	High Stage Valve	MEL 36-11-05	-
		High Stage Pressure Switch	MEL 36-11-05	-
A	HYD 1(2) LO QTY	Level in the reservoir of hydraulic system 1 is low	NO DISP	-
		Reservoir Quantity Indicator	MEL 29-30-00	-
A	HYD PUMP SELEC OFF	-	N/A	-
C	HYD SYS 1(2) FAIL	-	NO DISP	-
C	HYD SYS 1(2) OVHT	-	NO DISP	-
A	IC 1 FAN FAIL	-	NO DISP	-
C	IC 1 OVERHEAT	-	NO DISP	-
A	IC 1(2) CONFIG FAIL	IC-600 Configuration Module (IM-600)	MEL 31-42-02	-
		Other failures	NO DISP	-
C	IC 1(2) WOW INOP	-	NO DISP	-
A	IC 2 FAN FAIL	-	NO DISP	-
C	IC 2 OVERHEAT	-	NO DISP	-
C	IC BUS FAIL	-	NO DISP	-
W	ICE COND - A/I INOP	Eng Start Aux Relay or Air/Ground Relay	NO DISP	-
C	ICE DET 1(2) FAIL	Ice Detector	MEL 30-80-00	-
		Other failures	NO DISP	-

TYPE	MESSAGE	POSSIBLE FAILED COMPONENTS	REFER TO	REMARKS
C	ICE DETECTORS FAIL	Ice Detector	MEL 30-80-00	-
		Other failures	NO DISP	-
A	ICE/SPS ADVANCED, SPS/ICE SPEEDS	ICE/SPS ADVANCED, SPS/ICE SPEEDS message	MEL 27-36-01	-
A	IRS 1(2) ALN	-	N/A	IRS in the alignment mode
C	IRS 1(2) ALN FAULT	-	MEL 34-27-00	-
A	IRS 1(2) ATT MODE	-	MEL 34-27-00	-
A	IRS 1(2) EXC MOTION	-	N/A	A/C not stationary during IRS alignment
C	IRS 1(2) FAIL	-	MEL 34-27-00	-
A	IRS 1(2) NO MAG HDG	-	N/A	-
A	IRS 1(2) NO PPOS	-	N/A	-
A	IRS 1(2) ON BATT	-	N/A	-
C	IRS 1(2) OVERHEAT	-	NO DISP	-
W	LG / LEVER DISAGREE	-	NO DISP	-
C	LG AIR/GND FAIL	-	NO DISP	-
W	MAIN DOOR OPN	Door Warning Microswitches	MEL 52-70-00	False Warning
		Door Actuating and Locking Mechanism	NO DISP	Actual Warning
C	NLG UP/DOOR OPN	-	NO DISP	-

TYPE	MESSAGE	POSSIBLE FAILED COMPONENTS	REFER TO	REMARKS
C	NO ICE - A/ICE ON	-	N/A	Actual Caution
		Wing anti-icing valve	MEL 30-11-01	False Caution
		Stab anti-icing valve	MEL 30-12-01	False Caution
		Engine air inlet anti-icing valve	MEL 30-21-01	False Caution
W	NO TAKEOFF CONFIG	-	NO DISP	-
C	OXYGEN LO PRESS	Oxygen Pressure Transducer	MEL 35-11-00	-
		Other failures	NO DISP	-
C	PACK 1(2) OVHT	Air Conditioning Pack Systems	MEL 21-51-00	-
		Other failures	NO DISP	-
C	PACK 1(2) OVLD	Air Conditioning Pack Systems	MEL 21-51-00	-
		Other failures	NO DISP	-
A	PACK 1(2) VLV CLSD	Air Conditioning Pack Systems	MEL 21-51-00	False Advisory
		-	N/A	Actual Advisory
C	PACK 1(2) VLV FAIL	Engine Bleed Valve	MEL 36-11-05	In case Pack Valve Fails Open
		Pack Valve	MEL 21-51-00	-
W	PIT TRIM 1 INOP, PTRIM MAIN INOP	-	NO DISP	-
W	PIT TRIM 2 INOP, PTRIM BACKUP INOP	-	NO DISP	-
C	PITOT 1(2) INOP		MEL 30-31-00	-
C	PITOT 3 INOP	-	NO DISP	-

TYPE	MESSAGE	POSSIBLE FAILED COMPONENTS	REFER TO	REMARKS
C	PRESN AUTO FAIL	Pressurization Control System	MEL 21-30-00	-
		Electropneumatic Outflow Valve	MEL 21-31-03	-
		Other failures	NO DISP	-
C	PTRIM BKP SW FAIL	-	NO DISP	-
C	PTRIM CPT SWITCH	-	NO DISP	-
C	PTRIM F/O SW FAIL	-	NO DISP	-
A	RAD ALT 1(2) FAIL	Radio Altimeter	MEL 34-31-00	-
A	RAD ALT FAIL	Radio Altimeter	MEL 34-31-00	-
C	RAM AIR VLV FAIL	Ram Air Valves	MEL 21-25-01	-
		RH (LH) Pack Valve	MEL 21-51-00	-
C	ROLL LEFT(RIGHT) MISTRIM	Roll Trim Actuator	NO DISP	-
		Autopilot	MEL 22-10-00	-
C	RUDDER HARDOVER PROT FAIL	-	NO DISP	-
C	RUDDER OVERBOOST	-	NO DISP	-
C	RUDDER SYS 1 INOP	-	NO DISP	-
C	RUDDER SYS 1-2 INOP	-	NO DISP	-
C	RUDDER SYS 2 INOP	-	NO DISP	-
W	SERVICE DOOR OPN	Door Warning Microswitches	MEL 52-70-00	False Warning
		Door Actuating and Locking Mechanism	NO DISP	Actual Warning
C	SHED BUS 1(2) OFF	-	NO DISP	-
C	SPBK LVR DISAGREE	-	NO DISP	-
C	SPOILER FAIL	-	NO DISP	-
W	SPS 1 INOP	-	NO DISP	-

TYPE	MESSAGE	POSSIBLE FAILED COMPONENTS	REFER TO	REMARKS
W	SPS 1-2 INOP	-	NO DISP	-
W	SPS 2 INOP	-	NO DISP	-
C	SPS ADVANCED	-	NO DISP	-
C	STAB A/ICE FAIL	STAB A/ICE System	MEL 30-12-00	-
		STAB A/ICE VLV	MEL 30-12-01	-
C	STEER INOP	External disengagement switch	MEL 32-50-00	-
		-	NO DISP	-
C	STICK PUSHER FAIL	-	NO DISP	-
C	TAT 1(2) HEAT INOP	TAT Heater System	MEL 30-33-01	-
C	TERR INOP	FMS	MEL 34-60-00	-
		GPWS/Windshear Computer	MEL 34-41-00	-
		Other failures	NO DISP	-
C	W/S 1(2) HEAT FAIL	W/S Heating System	MEL 30-42-02	-
C	WG 1(2) A/ICE FAIL	Wing A/ICE System	MEL 30-11-00	-
		Wing A/ICE Valve	MEL 30-11-01	-
C	WG A/ICE ASYMETRY	Wing A/ICE Valve	MEL 30-11-01	-
C	WG A/ICE FAIL	WING A/ICE System	MEL 30-11-00	-
		Wing A/ICE Valve	MEL 30-11-01	-
C	WINDSHEAR INOP	GPWS/Windshear Computer	MEL 34-41-00	-
		Other failures	NO DISP	-
C	YAW DAMPER FAIL	Yaw Damper	MEL 22-10-00	-



MINIMUM EQUIPMENT LIST

EMBRAER 145LR

AIRCRAFT: EMB-145			REVISION NO: Re-Edición DATE: 08/12/2014		PAGE: 21-1	
SYSTEM & SEQUENCE NUMBERS	ITEM	1. CAT	2. NUMBER INSTALLED			4. REMARKS OR EXCEPTIONS
			3. NUMBER REQUIRED FOR DISPATCH			
21 AIR CONDITIONING						
22-04	External Ground Connector Check Valve	B	1	0	(M) (O) May be inoperative open provided flight is conducted in an unpressurized configuration.	
		C	1	0	May be inoperative closed.	
22-06	Baggage Compartment Ventilation System	C	1	0	(M) May be inoperative provided: a) Ventilation system remains closed, and b) Live animals are not carried in the cargo compartment.	
23-03	Gasper Fan	C	1	0	(M) May be inoperative on ground with the avionics busses energized provided: a) If doors are open: Both packs operate normally and remain in continuous operation, and ambient temperature is below ISA + 25 degrees C, b) If doors are closed: At least one pack operates normally and remains in continuous operation, and ambient temperature is below ISA + 32 degrees C, and c) Gasper fan is deactivated. NOTE 1: Avionics buses energized on the ground are limited to 10 minutes if doors are open and both packs are not operating. NOTE 2: Conditions above are applicable to ground operation only. There is no restriction to in-flight operation with gasper fan inoperative. NOTE 3: Doors referred to above include main, service and cargo compartment doors.	

AIRCRAFT:		REVISION NO: Re-Edición		PAGE:	
EMB-145		DATE: 08/12/2014		21-2	
SYSTEM & SEQUENCE NUMBERS	ITEM	1. CAT	2. NUMBER INSTALLED		
			3. NUMBER REQUIRED FOR DISPATCH		
21 AIR CONDITIONING		4. REMARKS OR EXCEPTIONS			
24-01	Recirculation Fans				
	1) Airplanes equipped with conventional electromechanical standby instruments	C	2	0	(M) May be inoperative provided failed fan is deactivated.
	2) Airplanes equipped with Integrated Standby Instrument System (ISIS)				Not Installed.
24-02	Recirculation Fan Valves				
		C	2	0	(M) May be inoperative open provided associated recirculation fan is verified to operate normal
		C	2	0	(M) May be inoperative closed provided associated recirculation fan is deactivated and considered inoperative.
24-03	Air Distribution Valves	C	2	1	(M) One may be inoperative provided remaining valve is deactivated in open position.
25-01	Ram Air Valves				
	1) Airplanes equipped with conventional electro-mechanical standby instruments	C	2	1	(M) (O) One may be inoperative provided: <ul style="list-style-type: none"> a) Associated air conditioning pack remains off, b) Affected ram air valve is verified to be in emergency ram air position, and c) Flight is conducted at or below FL 250.
		C	2	0	(M) (O) May be inoperative provided: <ul style="list-style-type: none"> a) Both packs remain off, b) Flight is conducted in an unpressurized configuration, c) Ram air valves are verified to be in emergency ram air position, and d) Ambient temperature on the ground is below ISA +21degrees C.

AIRCRAFT:		REVISION NO: Revisión 09		PAGE:		
EMB-145		DATE: 26/02/2021		21-3		
SYSTEM & SEQUENCE NUMBERS	ITEM	1. CAT	2. NUMBER INSTALLED			4. REMARKS OR EXCEPTIONS
			3. NUMBER REQUIRED FOR DISPATCH			
21 AIR CONDITIONING						
25-01	Ram Air Valves (Cont'd)					
	2) Airplanes equipped with Integrated Standby Instrument System (ISIS)					Not installed.
25-02	Ram Air Check Valves	C	2	0		(M) (O) May be inoperative open provided flight is conducted in an unpressurized configuration.
26-00	Forward Electronic Compartment Ventilation System					
	1) Exhaust Fan/Air Shutoff Valves	C	2	1		One exhaust fan or one shutoff valve may be inoperative.
	2) Exhaust Fan/NACA Cover Linear Actuators	C	2	1		Not Applicable
30-00	Pressurization Control System					
	1) Automatic Mode	C	1	0		(M) (O) May be inoperative provided: a) Manual mode is verified operative, b) Electropneumatic outflow valve is secured closed, and c) Cabin differential pressure indication, cabin rate of change indication, and cabin altitude indication operate normally.
	2) Manual Mode	C	1	0		(M) (O) May be inoperative provided: a) Flight is conducted in an unpressurized configuration, and b) Both outflow valves are secured open.
	3) Automatic and Manual Modes	C	2	0		(M) (O) May be inoperative provided: a) Flight is conducted in an unpressurized configuration, and b) Both outflow valves are secured open.

AIRCRAFT:		REVISION NO: Revisión 09		PAGE:	
EMB-145		DATE: 26/02/2021		21-4	
SYSTEM & SEQUENCE NUMBERS	ITEM	1. CAT	2. NUMBER INSTALLED		
			3. NUMBER REQUIRED FOR DISPATCH		
21 AIR CONDITIONING		4. REMARKS OR EXCEPTIONS			
31-03	Outflow Valves.				
1)	Electropneumatic	C	1	0	(M) (O) May be inoperative provided: a) Valve is secured closed, b) Manual pressurization control mode operates normally, and c) Cabin differential pressure indication, cabin rate of change indication, and cabin altitude indication operate normally.
2)	Pneumatic	C	1	0	(M) (O) May be inoperative provided: a) Flight is conducted in an unpressurized configuration and b) Both outflow valves are secured open.
3)	Electropneumatic and Pneumatic	C	2	0	(M) (O) May be inoperative provided: a) Flight is conducted in an unpressurized configuration, and b) Both outflow valves are secured open.

AIRCRAFT:		REVISION NO: Re-Edición		PAGE:	
EMB-145		DATE: 08/12/2014		21-5	
SYSTEM & SEQUENCE NUMBERS	ITEM	1. CAT	2. NUMBER INSTALLED		
			3. NUMBER REQUIRED FOR DISPATCH		
21 AIR CONDITIONING			4. REMARKS OR EXCEPTIONS		
32-01	Cabin Pressure Acquisition Module (CPAM).	C	1	0	(M) (O) May be inoperative provided flight is conducted in an unpressurized configuration.
	1) 10000 FT Warning	C	1	0	(O) May be inoperative provided flight is conducted at or below 10000 ft MSL.
	2) Cabin Differential Pressure Indication	C	1	0	(O) May be inoperative provided: <ul style="list-style-type: none"> a) Cabin altitude and cabin rate of change indication operates normally, and b) A chart is provided to convert cabin altitude into differential pressure.
	3) Cabin Rate of Change Indication	C	1	0	May be inoperative provided: <ul style="list-style-type: none"> a) Automatic pressurization control mode operates normally, and b) Cabin differential pressure indication and cabin altitude indication are operating normally.
	4) Cabin Altitude Indication	C	1	0	(O) May be inoperative provided: <ul style="list-style-type: none"> a) Cabin differential pressure indication operates normally, b) A chart is provided to convert cabin differential pressure into cabin altitude indication, and c) Automatic pressurization control mode operates normally.



MINIMUM EQUIPMENT LIST

EMBRAER 145LR

AIRCRAFT:		REVISION NO: Re-Edición		PAGE:	
EMB-145		DATE: 08/12/2014		21-6	
SYSTEM & SEQUENCE NUMBERS		1. CAT	2. NUMBER INSTALLED		
ITEM			3. NUMBER REQUIRED FOR DISPATCH		
21 AIR CONDITIONING			4. REMARKS OR EXCEPTIONS		
32-02	Cabin Pressure Control System High Altitude Mode	D	1	0	May be inoperative provided takeoff and landing is limited to airports below 10000 feet MSL.
51-00	Air Conditioning Pack Systems.				
1)	Airplanes equipped with conventional electro-mechanical standby instruments.	C	2	1	One may be inoperative provided flight is conducted at or below FL250.
		C	2	0	(M) (O) May be inoperative provided: 1) Both ram air valves operate normally, 2) Flight is conducted in an unpressurized configuration, and 3) Ambient temperature on the ground is below ISA +21degrees C.
2)	Airplanes equipped with Integrated Standby Instrument System (ISIS)				Not installed.



MINIMUM EQUIPMENT LIST

EMBRAER 145LR

AIRCRAFT:		REVISION NO: Re-Edición		PAGE:	
EMB-145		DATE: 08/12/2014		21-7	
SYSTEM & SEQUENCE NUMBERS	ITEM	1. CAT	2. NUMBER INSTALLED		
			3. NUMBER REQUIRED FOR DISPATCH		
21 AIR CONDITIONING		4. REMARKS OR EXCEPTIONS			
60-04	Cockpit Automatic and Manual Temperature Control Systems.				
1)	Automatic System	C	1	0	(O) May be inoperative provided associated manual temperature control mode operates normally.
2)	Manual System	C	1	0	May be inoperative provided associated automatic temperature control mode operates normally.
3)	Both Systems (Airplanes equipped with conventional electro-mechanical standby instruments).	C	2	0	May be inoperative provided associated automatic temperature control mode operates normally. (O) May be inoperative provided: a) Pack 1 remains off, and b) Flight is conducted at or below FL 250.
4)	Both Systems (Airplanes equipped with Integrated Standby Instrument System (ISIS)).	-	-	-	Not installed

AIRCRAFT:		REVISION NO: Re-Edición		PAGE:	
EMB-145		DATE: 08/12/2014		21-8	
SYSTEM & SEQUENCE NUMBERS		1. CAT	2. NUMBER INSTALLED		
ITEM		3. NUMBER REQUIRED FOR DISPATCH			
21 AIR CONDITIONING		4. REMARKS OR EXCEPTIONS			
60-05	Cabin Automatic and Manual Temperature Control Systems.				
1)	Automatic System.	C	1	0	(O) May be inoperative provided associated manual temperature control mode operates normally.
2)	Manual System.	C	1	0	May be inoperative provided associated automatic temperature control mode operates normally.
3)	Both Systems (Airplanes equipped with conventional electro-mechanical standby instruments).	C	2	0	(O) May be inoperative provided: a) Pack 2 remains off, and b) Flight is conducted at or below FL 250.
4)	Both Systems (Airplanes equipped with Integrated Standby Instrument System (ISIS)).				Not installed.
60-06	Attendant's Temperature Control	C	1	0	May be inoperative provided Passenger Cabin Temperature and Mode Selector Knob operates normally.
61-02	Cockpit and Cabin Temperature Indication	C	2	0	

AIRCRAFT:		REVISION NO: Revisión 09			PAGE:	
EMB-145		DATE: 26/02/2021			22-1	
SYSTEM & SEQUENCE NUMBERS		1. CAT	2. NUMBER INSTALLED			
ITEM			3. NUMBER REQUIRED FOR DISPATCH			
			4. REMARKS OR EXCEPTIONS			
22 AUTO FLIGHT						
10-00	Autopilot/Flight Director Functions					
1)	Autopilot Function	B	1	0	May be inoperative provided enroute or approach procedures do not require its use.	
2)	Flight Director Function	C	1	0	Note: If not have this equipment Aircraft is not Allowed to fly into RVSM according to NOM-091-SCT3-2004.	
3)	Yaw Damper Function	B	1	0	May be inoperative provided enroute or approach procedures do not require its use.	
					NOTE: Autopilot will not engage with yaw damper inoperative.	
11-01	Flight Guidance Controller Panel					
1)	Flight Director (FD)Buttons	C	2	0	(O) Both may be inoperative.	
2)	Course Synchronization (CRS PUSH SYNC) Buttons	C	2	0		
3)	Autopilot (AP)Engage Button	C	1	0	May be inoperative provided autopilot function is considered inoperative.	
					Note: If not have this equipment Aircraft is not Allowed to fly into RVSM according to NOM-091-SCT3-2004.	
4)	Autopilot Couple (CPL)Button	C	1	0		
5)	Yaw Damper (YD) Engage Button	C	1	0	(O) May be inoperative provided yaw damper is verified to operate normally.	
6)	Heading (HDG)Mode Button	B	1	0	May be inoperative provided procedures do not require its use.	
7)	Navigation (NAV) Mode Button	C	1	0	May be inoperative provided procedures do not require its use.	
8)	Approach (APP)Mode Button	C	1	0	May be inoperative provided procedures do not require its use.	
					(Continued)	

AIRCRAFT:		REVISION NO: Revisión 09			PAGE:	
EMB-145		DATE: 26/02/2021			22-2	
SYSTEM & SEQUENCE NUMBERS		1. CAT	2. NUMBER INSTALLED			
ITEM		3. NUMBER REQUIRED FOR DISPATCH				
22 AUTO FLIGHT		4. REMARKS OR EXCEPTIONS				
11-01	Flight Guidance Controller Panel (Cont'd)					
9)	Low Bank (BNK) Mode Button	C	1	0	May be inoperative provided procedures do not require its use.	
10)	Heading Select Knob	B	1	0	May be inoperative provided procedures do not require its use.	
11)	Heading Synchronization (HDG PUSH SYNC) Button	C	1	0	May be inoperative provided procedures do not require its use.	
12)	Speed Hold (SPD) Mode Button	C	1	0	May be inoperative provided procedures do not require its use.	
13)	Flight Level Change (FLC) Mode Button	C	1	0	May be inoperative provided procedures do not require its use.	
14)	Vertical Speed Hold (VS) Mode Button	C	1	0	May be inoperative provided procedures do not require its use.	
15)	Speed Selector Control Knob	C	1	0	May be inoperative provided procedures do not require its use.	
16) ***	Autothrottle	C	2	0	Not installed.	
17)	IAS/M Selector (PUSH IAS/M) Button	C	1	0		
18)	Altitude Hold (ALT) Mode Button	C	1	0	(O) May be inoperative provided: a) Altitude Preselect knob operates normally, and b) Procedures do not require its use.	
19)	Altitude Preselect Knob (ASEL)	A	1	0	May be inoperative provided: a) Altitude Preselect function is considered inoperative, b) Procedures do not require its use, and c) Repairs are made within three flight days.	
20) ***	Autothrottle (A/T) Button	C	1	0	Not installed.	



MINIMUM EQUIPMENT LIST

EMBRAER 145LR

AIRCRAFT:		REVISION NO: Re-Edición		PAGE:	
EMB-145		DATE: 08/12/2014		22-3	
SYSTEM & SEQUENCE NUMBERS	ITEM	1. CAT	2. NUMBER INSTALLED		
			3. NUMBER REQUIRED FOR DISPATCH		
22 AUTO FLIGHT				4. REMARKS OR EXCEPTIONS	
11-08	Touch Control Steering Button (TCS Sync Buttons)	C	2	0	May be inoperative in the deactivated condition.
11-09	Go-Around Buttons	C	2	0	May be inoperative provided: <ul style="list-style-type: none"> a) Enroute or approach procedures do not require its use, and b) Affected button is failed in the deactivated condition. NOTE: In case of dual failure, only automatic engagement of Windshear Escape Guidance Mode by positioning TLA above 78 degrees operates normally.



MINIMUM EQUIPMENT LIST

EMBRAER 145LR

AIRCRAFT:		REVISION NO: Re-Edición		PAGE:	
EMB-145		DATE: 08/12/2014		23-1	
SYSTEM & SEQUENCE NUMBERS	ITEM	1. CAT	2. NUMBER INSTALLED		
			3. NUMBER REQUIRED FOR DISPATCH		
23 COMMUNICATIONS		4. REMARKS OR EXCEPTIONS			
00-00	Communications System (VHF, HF, UHF)				
1)	Very High Frequency (VHF) Communication System	D	2	1	Any in excess of those required by national authority may be inoperative provided it is not powered by an essential bus and not required for emergency procedures.
2)	High Frequency (HF) Communication System				Not installed.
3)	Ultra High Frequency (UHF) Communication System				Not installed.
15-00	Satellite Communication System (SATCOM)				Disable.
20-01	ACARS System				Not installed.
21-01	Selective Call System (SELCAL)				Not installed.
24-00	Controller to Pilot Data Link (CPDLC)				Not Installed.



MINIMUM EQUIPMENT LIST

EMBRAER 145LR

AIRCRAFT:		REVISION NO: Revisión 03		PAGE:	
EMB-145		DATE: 01/09/2015		23-2	
SYSTEM & SEQUENCE NUMBERS	ITEM	1. CAT	2. NUMBER INSTALLED		
			3. NUMBER REQUIRED FOR DISPATCH		
23 COMMUNICATIONS			4. REMARKS OR EXCEPTIONS		
30-01	Passenger Address System				
1)	Passenger Configuration	B	1	0	(O) May be inoperative provided: a) Alternate, normal and emergency procedures and/or operating restrictions are established and used, and b) Flight attendant alerting system (chime and pilot attendant call light) operates normally. NOTE: Any station function(s) that operate normally may be used.
		C	1	0	(O) May be inoperative provided: a) PA not required by local Authority, and b) Alternate, normal and emergency procedures and/or operating restrictions are established and used. NOTE: Any station function(s) that operate normally may be used.
	a) Lavatory Speakers	C	1	0	(O) May be inoperative provided alternate procedures are established and used.



MINIMUM EQUIPMENT LIST

EMBRAER 145LR

AIRCRAFT:		REVISION NO: Re-Edición		PAGE:	
EMB-145		DATE: 08/12/2014		23-3	
SYSTEM & SEQUENCE NUMBERS	ITEM	1. CAT	2. NUMBER INSTALLED		
			3. NUMBER REQUIRED FOR DISPATCH		
23 COMMUNICATIONS			4. REMARKS OR EXCEPTIONS		
31-01	Crewmember Interphone System(s)				
1)	Passenger Configuration				
	a) Flight Deck to Cabin, Cabin to Flight Deck Functions	B	1	0	(O) May be inoperative provided: <ul style="list-style-type: none"> a) Flight deck to cabin and cabin to flight deck interphone functions operate normally on at least fifty percent of the cabin handsets, and b) Alternate communication procedures between the affected flight attendant stations are established and used. NOTE: Any station function(s) that operate normally may be used.
	b) Cabin to Cabin Function	B	2	0	(O) May be inoperative provided alternate communication procedures between the affected flight attendant stations are established and used. NOTE: Any station function(s) that operate normally may be used.
	c) Flight Deck to Ground Function				
	ii) All Other Aircraft/Operations	C	2	0	(O) May be inoperative provided alternate procedures are established and used.
		D	2	0	May be inoperative provided procedures do not require its use.



MINIMUM EQUIPMENT LIST

EMBRAER 145LR

AIRCRAFT:		REVISION NO: Re-Edición		PAGE:	
EMB-145		DATE: 08/12/2014		23-4	
SYSTEM & SEQUENCE NUMBERS	ITEM	1. CAT	2. NUMBER INSTALLED		
			3. NUMBER REQUIRED FOR DISPATCH		
23 COMMUNICATIONS		4. REMARKS OR EXCEPTIONS			
31-02	Alerting Systems (Audio/Visual)				
	1) Passenger Configuration				
	a) Flight Deck Call Visual Alerting System	B	1	0	May be inoperative provided the flight deck audio alerting system operates normally. NOTE: The flight deck audio alerting must always be operative.
	b) Flight Attendant Visual Alerting System	B	1	0	(O) May be inoperative provided: a) PA system operates normally, b) If affected light is used for lavatory smoke detector alerting, an alternate lavatory smoke alert (audio or visual) is installed and operates normally, and c) Alternate procedures for contacting flight attendants are established and used. NOTE 1: Passenger to Attendant Call System is considered Non-Essential Equipment and Furnishing (NEF).
	c) Flight Attendant Audio Alerting System	B	-	0	(O) May be inoperative provided: a) PA system operates normally, b) If affected chime is used for lavatory smoke detector alerting, an alternate lavatory smoke alert (audio or visual) is installed and operates normally, and c) Alternate procedures for contacting flight attendants are established and used. NOTE 1: Passenger to Attendant Call System is considered Non-Essential Equipment and Furnishing (NEF). NOTE 2: Any audio alerting system function(s) that operates normally may be used.



MINIMUM EQUIPMENT LIST

EMBRAER 145LR

AIRCRAFT:		REVISION NO: Revisión 09		PAGE:	
EMB-145		DATE: 26/02/2021		23-5	
SYSTEM & SEQUENCE NUMBERS	ITEM	1. CAT	2. NUMBER INSTALLED		
			3. NUMBER REQUIRED FOR DISPATCH		
23 COMMUNICATIONS		4. REMARKS OR EXCEPTIONS			
31-03	Handset Systems 1) Passenger Configuration a) Cabin Attendant Handsets	B	2	1	(O) May be inoperative provided: a) Fifty percent of cabin handsets operate normally, and b) Alternate communication procedures between the affected Flight Attendants station(s) are established and used. NOTE 1: An operative handset at an inoperative flight attendant seat shall not be counted to satisfy the fifty percent requirement. NOTE 2: Any handset function(s) that operate normally may bemused.
32-02 ***	Prerecorded Passenger Announcement System	D	1	0	(O) May be inoperative provided alternate procedures are established and used.
33-01	Passenger Cabin Speakers	C	-	-	May be inoperative provided any seat from which a passenger cannot clearly hear a passenger address announcement is not occupied.
		C	-	0	May be inoperative provided Passenger Address System is considered inoperative.
51-03	Push To Talk (PTT) (Button on Glareshield Panel Control Wheel)	C	4	2	Two may be inoperative provided one button at each pilot's station operates normally.
51-04	Flight Deck Speakers	C	2	0	May be inoperative provided headsets operate normally.
51-05	Flight Deck Headsets	D	3	2	Any in excess of those required for each person on flight deck duty maybe inoperative or missing.



MINIMUM EQUIPMENT LIST

EMBRAER 145LR

AIRCRAFT:		REVISION NO: Revisión 03		PAGE:		
EMB-145		DATE: 01/09/2015		23-6		
SYSTEM & SEQUENCE NUMBERS	ITEM	1. CAT	2. NUMBER INSTALLED			4. REMARKS OR EXCEPTIONS
			3. NUMBER REQUIRED FOR DISPATCH			
23 COMMUNICATIONS						
51-07	Flight Deck Handheld Microphones	C	2	0	May be inoperative provided associated boom microphones operate normally.	
51-10	Interphone System (Flight Deck to Ramp)/(Ramp to Flight Deck)				Deleted, Rev 9a.	
51-12	Boom Microphones				Deleted, Rev 13.	
70-00	Flight deck Door Monitoring System				Not installed.	
71-00	Cockpit Voice Recorder System	A	1	1		
73-00	Video Surveillance System (VSS)				Not installed.	
80-00	Radio Management Units (RMU's)					
	1) NAV/Comm Tuning Function	C	2	1		
	2) Memory Function	C	2	0	May be inoperative provided tuning function operates normally.	
81-02	Tuning Backup Control Head	C	1	0	May be inoperative provided both Radio Management Units operate normally	



MINIMUM EQUIPMENT LIST

EMBRAER 145LR

AIRCRAFT:		REVISION NO: Revisión 09		PAGE:	
EMB-145		DATE: 26/02/2021		24-1	
SYSTEM & SEQUENCE NUMBERS	ITEM	1. CAT	2. NUMBER INSTALLED		
			3. NUMBER REQUIRED FOR DISPATCH		
24 ELECTRICAL POWER			4. REMARKS OR EXCEPTIONS		
20-01	Generator Current Indications	C	4	2	(O) One may be inoperative on each side provided: <ul style="list-style-type: none"> a) Associated voltage indication operates normally, and b) Remaining generator on the same side operates normally.
20-02	Generator Voltage Indications	C	4	2	One may be inoperative on each side provided associated current indication operates normally.
20-03 ***	Inverter	A	1	0	May be inoperative provided: <ul style="list-style-type: none"> a) GPWS/Windshear powered by 115V AC is considered inoperative, b) TCAS powered by 115V AC is considered inoperative, and c) Repairs are made within one flight days.
31-01	Engine Driven Generators				
1)	Airplanes equipped with conventional electro-mechanical standby instruments	B	4	3	(M) (O) Except for ER operations beyond 120 minutes, one may be inoperative provided APU generator operates normally and is operated during takeoff and landing.
2)	Airplanes equipped With Integrated Standby Instrument System (ISIS)	-	-	-	Not installed



MINIMUM EQUIPMENT LIST

EMBRAER 145LR

AIRCRAFT:		REVISION NO: Re-Edición		PAGE:	
EMB-145		DATE: 08/12/2014		24-2	
SYSTEM & SEQUENCE NUMBERS	ITEM	1. CAT	2. NUMBER INSTALLED		
			3. NUMBER REQUIRED FOR DISPATCH		
24 ELECTRICAL POWER			4. REMARKS OR EXCEPTIONS		
31-02	Engine Driven Generator Bearings (Only for Generator Model 30086-011)	A	4	3	Advisory message GEN BRG FAIL may be present for one generator provided: a) EICAS Caution messages GEN OFF BUS for the affected generator was not displayed during the previous flight, and b) Repairs are made within 20 flight hours.
34-01	APU Starter Generator				
1)	Starter Function	C	1	0	May be inoperative provided APU is considered inoperative.
2)	Generator Function	C	1	0	May be inoperative provided engine driven generators operate normally.
37-00	DC/DC Power Conversion System				Not installed.
40-00	External Power System	C	1	0	
1)	GPU AVAIL Lights	C	2	0	



MINIMUM EQUIPMENT LIST

EMBRAER 145LR

AIRCRAFT: EMB-145			REVISION NO: Re-Edición DATE: 08/12/2014		PAGE: 25-1
SYSTEM & SEQUENCE NUMBERS			1. CAT	2. NUMBER INSTALLED	
ITEM			3. NUMBER REQUIRED FOR DISPATCH		
25 EQUIPMENT/FURNISHINGS			4. REMARKS OR EXCEPTIONS		
11-00	Eye Locator	C	1	0	
11-01	Flight Crew Seats				
1)	Vertical Power Seat Adjustment Systems	C	2	0	(M) (O) May be inoperative provided: a) System is deactivated, and b) Manual seat adjustment operates normally.
2)	Manual Vertical Adjustments	C	2	0	(M) May be inoperative provided: a) Seat(s) are locked in a position that permits normal pilots visibility, b) Full flight control movement is available, and c) Position of seat is acceptable to flight crew.
3)	Lumbar Supports	C	2	0	May be inoperative provided seat is acceptable to affected crewmember.
4)	Armrests	C	4	0	
5)	Recline Functions	C	2	0	May be inoperative provided seat is acceptable to affected crewmember.
6)	Lateral Adjustments	C	2	0	May be inoperative with the seat at the central position provided fore/aft adjustments are operative and seat is acceptable to affected crewmember.
7)	Aft/Fore Adjustment Levers (Airplanes equipped with 2 adjustment levers per seat)	D	4	2	One lever per seat may be inoperative or broken provided: a) The remaining lever on seat operates normally, and b) The inoperative or broken lever on affected seat does not pose a hazard to the crew or interfere with proper seat operation.
8)	Thigh Support	C	2	0	May be inoperative provided seat is acceptable to affected crewmember.



MINIMUM EQUIPMENT LIST

EMBRAER 145LR

AIRCRAFT:		REVISION NO: Re-Edición		PAGE:	
EMB-145		DATE: 08/12/2014		25-2	
SYSTEM & SEQUENCE NUMBERS	ITEM	1. CAT	2. NUMBER INSTALLED		
			3. NUMBER REQUIRED FOR DISPATCH		
25 EQUIPMENT/FURNISHINGS			4. REMARKS OR EXCEPTIONS		
11-02	Primary Observer Seat (Including associated equipment)	A	1	0	<p>May be inoperative provided:</p> <ul style="list-style-type: none"> a) A passenger seat in the passenger cabin is made available to an AFAC inspector for the performance of official duties, and b) Repairs are made within two flight days.
		A	1	0	<p>May be inoperative provided:</p> <ul style="list-style-type: none"> a) Required minimum safety equipment (safety belt and oxygen) is available, b) Seat is acceptable to an AFAC inspector for the performance of official duties, and c) Repairs are made within two flight days. <p>NOTE 1: These provisos are intended to provide for occupancy of the above seat by an AFAC inspector when the minimum safety equipment (oxygen and safety belt) is functional and the inspector determines the conditions to be acceptable.</p> <p>NOTE 2: The pilot-in-command will determine if the minimum safety equipment is functional for other persons authorized to occupy observer seat.</p>



MINIMUM EQUIPMENT LIST

EMBRAER 145LR

AIRCRAFT:		REVISION NO: Re-Edición		PAGE:	
EMB-145		DATE: 08/12/2014		25-3	
SYSTEM & SEQUENCE NUMBERS		1. CAT	2. NUMBER INSTALLED		
ITEM		3. NUMBER REQUIRED FOR DISPATCH			
25 EQUIPMENT/FURNISHINGS		4. REMARKS OR EXCEPTIONS			
11-04	Flight Attendant Seat Assembly				
1)	Aircraft with Only One Flight Attendant Seat				
	a) Forward Seat Assembly	A	1	0	(M) (O) May be inoperative provided: a) Affected seat is not occupied, b) Flight attendant(s) displaced by inoperative seat occupies the passenger seat most accessible to the inoperative seat, c) Alternate procedures are established and used as published in crewmember manuals, d) Folding type seat is stowed or is secured in the retracted position, e) Passenger seat assigned to flight attendant is placarded "FOR FLIGHT ATTENDANT USE ONLY" f) Repairs are made within two flight days. NOTE 1: An automatic folding seat that will not stow automatically is considered inoperative. NOTE 2: A seat position with an inoperative or missing restraint system is considered inoperative. NOTE 3: The above provisos apply to flight attendant seats. Individual operators, when operating with inoperative seats, will consider the locations and combinations of seats to ensure that the proximity to exits and distribution requirements of the applicable regulations are met.
	b) Aft Flight attendant seat	C	1	0	Not used
12-01	Sunvisors	C	2	0	May be inoperative or missing provided there are no visual restrictions to flight crew.



MINIMUM EQUIPMENT LIST

EMBRAER 145LR

AIRCRAFT:		REVISION NO: Revisión 09			PAGE:
EMB-145		DATE: 26/02/2021			25-4
SYSTEM & SEQUENCE NUMBERS	ITEM	1. CAT	2. NUMBER INSTALLED		
			3. NUMBER REQUIRED FOR DISPATCH		
25 EQUIPMENT/FURNISHINGS		4. REMARKS OR EXCEPTIONS			
12-02	Cockpit Convenience Item(s)	C	-	0	Cockpit convenience items are those items related to crewmember convenience or comfort such as, but not limited to: cap holders, ashtrays, footrests, etc. Items addressed elsewhere in this document shall not be included.
12-03	Lighted/Mechanical Checklist	C	-	0	
12-04	Chart Holders	C	4	2	May be inoperative or missing provided one is available at each pilot station.
21-05	Passenger Seat(s)	D	50	-	<p>May be inoperative provided:</p> <ul style="list-style-type: none"> a) Seat does not restrict access to any emergency exit, egress route, or main aisle and, b) The affected seat(s) are blocked and placarded "DO NOT OCCUPY". <p>NOTE 1: A seat with an inoperative seat belt or shoulder harness is considered inoperative.</p> <p>NOTE 2: Inoperative seats do not affect the required number of Flight Attendants.</p> <p>NOTE 3: Affected seat(s) may include the seat(s) behind and/or adjacent outboard seats.</p>
***	1) Positioning Controls for Taxi, Takeoff, and Landing (TTL) (Mechanical and/or electric).	D	-	-	(M) May be inoperative and seat occupied provided seat is secured in the taxi, takeoff, and landing (TTL) position.
		D	-	-	May be inoperative and seat occupied provided seat is immovable in the taxi, takeoff, and landing (TTL) position.
	2) Underseat Baggage Restraining Bars	C	50	0	<p>(O) May be inoperative provided:</p> <ul style="list-style-type: none"> a) Baggage is not stowed under seat with inoperative restraining bar, b) Associated seat is placarded "DO NOT STOW BAGGAGE UNDER THIS SEAT", and c) Procedures are established to alert Cabin Crew of inoperative restraining bar.



MINIMUM EQUIPMENT LIST

EMBRAER 145LR

AIRCRAFT:		REVISION NO: Revisión 09		PAGE:	
EMB-145		DATE: 26/02/2021		25-5	
SYSTEM & SEQUENCE NUMBERS		1. CAT	2. NUMBER INSTALLED		
ITEM		3. NUMBER REQUIRED FOR DISPATCH			
25 EQUIPMENT/FURNISHINGS		4. REMARKS OR EXCEPTIONS			
21-05	Passenger Seat(s) (Cont'd)				
	3) Armrests				
***	a) With Seat Positioning Controls for Taxi, Takeoff and Landing (TTL) and/or Other Controls	D	-	-	(M) May be inoperative or missing and seat occupied provided: a) Armrest does not restrict access to any emergency exit, egress route, or main aisle, and, b) If armrest with seat control is missing or removed, seat is secured in taxi, takeoff and landing (TTL) position.
	b) Without Seat Positioning Controls for Taxi, Takeoff, and Landing (TTL) and/or other controls	D	-	-	May be inoperative or missing and seat occupied provided: a) Armrest does not block an emergency exit, and b) Armrest does not restrict any passenger from access to the main aircraft aisle.
22-00	Overhead Storage Bin(s)/Cabin and Galley Storage Compartment/Closets	C	-	-	(M) May be inoperative provided: a) Procedures are established to secure compartment CLOSED, b) Associated bin or compartment is prominently placarded DO NOT USE, c) Compartment is not used for storage of emergency equipment, and d) Affected compartment is not used for storage of any item(s) except for those permanently affixed. NOTE: If no partitions are installed, the entire overhead storage compartment is considered one bin or compartment.



MINIMUM EQUIPMENT LIST

EMBRAER 145LR

AIRCRAFT: EMB-145		REVISION NO: Revisión 09 DATE: 26/02/2021		PAGE: 25-6	
SYSTEM & SEQUENCE NUMBERS		1. CAT	2. NUMBER INSTALLED		
ITEM		3. NUMBER REQUIRED FOR DISPATCH			
		4. REMARKS OR EXCEPTIONS			
25 EQUIPMENT/FURNISHINGS					
22-00	Overhead Storage Bin(s)/Cabin and Galley Storage Compartment/Closets (Cont'd)				
1)	Hinged door (s)	C	-	-	<p>(M) (O) May be inoperative provided:</p> <p>a) Affected door (s) is removed,</p> <p>b) Associated bin or compartment is not use for storage of any items, except those permanently affixed,</p> <p>c) Procedures bin or compartment is prominently placarded DO NOT USE,</p> <p>d) Procedures are stablished and used to alert crew members and passengers of inoperative bins, and</p> <p>e) Passengers are briefed that associated bin or compartment is not used.</p> <p>NOTE 1: If no partitions are installed, the entire overhead storage compartment is considered one bin or compartment.</p> <p>NOTE 2: Any emergency equipment located in the associated compartment (permanently affixed) is available for use.</p>
2)	Retractable Door (s)	C	-	-	<p>(M) (O) May be inoperative provided:</p> <p>a) Affected door (s) is removed or secured in the retracted (fully open) position,</p> <p>b) Associated bin or compartment is not use for storage of any items, except those permanently affixed,</p> <p>c) Associated bin or compartment is permanently placarded DO NOT USE,</p> <p>d) Procedures are stablished and used to alert crew members and passengers of inoperative bins, and</p> <p>e) Passengers are briefed that associated bin or compartment is not used.</p> <p>NOTE 1: If no partitions are installed, the entire overhead storage compartment is considered one bin or compartment.</p> <p>NOTE 2: Any emergency equipment located in the associated compartment (permanently affixed) is available for use.</p>



MINIMUM EQUIPMENT LIST

EMBRAER 145LR

AIRCRAFT:		REVISION NO: Revision 03		PAGE:	
EMB-145		DATE: 01/09/2015		25-7	
SYSTEM & SEQUENCE NUMBERS	ITEM	1. CAT	2. NUMBER INSTALLED		
			3. NUMBER REQUIRED FOR DISPATCH		
25 EQUIPMENT/FURNISHINGS			4. REMARKS OR EXCEPTIONS		
27-02	Lavatory Bulkhead Peephole	D	1	0	May be inoperative provided: a) Only the view capability is obstructed, and b) Bulkhead peephole is in place and not broken.
		D	1	0	(M)May be broken, missing or removed provided the hole is blocked by an acceptable means.
27-09	Forward Attendant Control Panel Cover	D	1	0	(M) May be inoperative provided the cover is removed.
30-01	Galley Waste Receptacles Access Doors/Covers	C	1	0	(M) (O) May be inoperative provided: a) The container is empty and the access is secured to prevent waste introduction into the compartment, and b) Procedures are established to ensure that sufficient galley waste receptacles are available to accommodate all waste that may be generated on a flight.
32-01	Main Door Acoustic Curtain				Deleted, Rev 2a.
40-00	Exterior Lavatory Door Ashtrays				
	1) Airplanes with only one exterior lavatory door ashtray installed	A	1	0	May be inoperative or missing for 10 calendar days.



MINIMUM EQUIPMENT LIST

EMBRAER 145LR

AIRCRAFT:		REVISION NO: Revisión 09		PAGE:	
EMB-145		DATE: 26/02/2021		25-8	
SYSTEM & SEQUENCE NUMBERS		1. CAT	2. NUMBER INSTALLED		
ITEM			3. NUMBER REQUIRED FOR DISPATCH		
			4. REMARKS OR EXCEPTIONS		
25 EQUIPMENT/FURNISHINGS					
50-01	Cargo Restraint Systems	C	1	0	May be inoperative or missing provided approved cargo loading limits are observed. The source documents are only the Type Certificate (TC)/Supplemental Type Certificate (STC)/Airplane Flight Manual (AFM) or the separate TC/STC Weight and Balance Manual (WBM).
		C	1	0	May be inoperative or missing provided baggage compartment remains empty.
	1) Horizontal Net	C	1	0	May be inoperative or missing provided approved cargo loading limits are observed. The source documents are only the Type Certificate (TC)/Supplemental Type Certificate (STC)/Airplane Flight Manual (AFM) or the separate TC/STC Weight and Balance Manual (WBM). NOTE 1: Baggage compartment loaded up to 2182 lb does not require the use of horizontal net. NOTE 2: Baggage compartment equipped with reinforced liners (airplanes Post-Mod. SB 145-25-0261 or equipped with an equivalent factory modification incorporated) does not require the use of horizontal net.
	2) Vertical Net	D	2	0	NOTE: The vertical net(s) and attachments are optional and may be removed or installed by the operator at their discretion.
	3) Door Safety Net	C	1	0	May be inoperative or missing provided cargo restraint net (horizontal net) is available and used.



MINIMUM EQUIPMENT LIST

EMBRAER 145LR

AIRCRAFT:		REVISION NO: Revisión 07			PAGE:
EMB-145		DATE: 04/07/2017			25-9
SYSTEM & SEQUENCE NUMBERS	ITEM	1. CAT	2. NUMBER INSTALLED		
			3. NUMBER REQUIRED FOR DISPATCH		
25 EQUIPMENT/FURNISHINGS			4. REMARKS OR EXCEPTIONS		
60-02	Non-Essential Equipment & Furnishings (NEF)	D	-	0	May be inoperative, damaged or missing as long as the component is deferred according with NEF list located in the NEF section of this MEL
60-04	Life Raft				Not installed.
60-05	Flight Deck/ Attendant Flashlight and Holder Assemblies	C	4	3	May be inoperative or missing provided affected crewmember has a flashlight of equivalent characteristics readily available. Note: One for each crewmember is required by the NOM-012-SCT3-2012.
60-06	Megaphones				Not installed
60-07	Pyrotechnic Signal Devices				Not installed.
60-09	Emergency Medical Equipment				Not installed.
1)	Automatic External Defibrillator (AED) and/or Associated Equipment				Not installed.
2)	Emergency Medical Kit (EMK) and/or Associated Equipment				Not installed.
3)	First Aid Kit (FAK) and/or Associated Equipment	A	1	1	(O) If more than one is required by NOM-012-SCT3-2012, only one of the required first aid kits may be incomplete, missing or inoperative provided: a) FAK is resealed in a manner that will identify it as a unit that cannot be mistaken for a fully serviceable unit, and: b) Repairs or replacement are made within 1 flight
		D	1	0	Any in excess of those required by NOM-012-SCT3-2012 may be incomplete, missing or inoperative.



MINIMUM EQUIPMENT LIST

EMBRAER 145LR

AIRCRAFT:		REVISION NO: Revisión 09		PAGE:	
EMB-145		DATE: 26/02/2021		25-10	
SYSTEM & SEQUENCE NUMBERS		1. CAT	2. NUMBER INSTALLED		
ITEM		3. NUMBER REQUIRED FOR DISPATCH			
25 EQUIPMENT/FURNISHINGS		4. REMARKS OR EXCEPTIONS			
60-10	Fasten Seat Belt While Seated" Sign or Placard	C	36	-	One or more signs or placards may be illegible or missing provided a legible sign or placard is readable from each occupied passenger seat.
61-01	Emergency Locator Transmitter (ELT)				
1) ***	Survival Type ELT	D	1	0	May be inoperative, according to state legislation, NOM-012-SCT3-2012, provided: a) Fixed Type ELT is fully operative.
		D	-	0	Any in excess of those required by the state legislation may be inoperative or missing.
2)	Fixed Type ELT	A	1	0	(M) May be inoperative, according to state legislation, provided: a) Survival Type ELT is fully operative, b) Until a place where repairs can be made within 90 days, c) Until a place where repairs can be made if the operator conducts a long ferry flight over the sea or designated areas as difficult rescue by the state within 90 days.
		A	-	0	May be missing provided: a) Placarding "ELT deactivated" is placed in view of the pilot, and b) Repairs are made within 90 days.
		D	-	-	(M) Any in excess of those required by the state legislation may be inoperative provided system is deactivated.
		D	-	-	Any in excess of those required by state legislation may be missing.
64-02	Floating Equipment (Crew and Passenger)	D	64	59	Must be provided in case that the flight will be in routes over water, according to state legislation, NOM-012-SCT3-2012. NOTE: One flotation equipment is required for each passenger.
		D	-	-	Any in excess of that required by state legislation may be inoperative or missing.



MINIMUM EQUIPMENT LIST

EMBRAER 145LR

AIRCRAFT: EMB-145			REVISION NO: Re-Edición DATE: 08/12/2014		PAGE: 26-1
SYSTEM & SEQUENCE NUMBERS	ITEM	1. CAT	2. NUMBER INSTALLED		
			3. NUMBER REQUIRED FOR DISPATCH		
26 FIRE PROTECTION			4. REMARKS OR EXCEPTIONS		
12-00	APU Fire Detection System	C	1	0	May be inoperative provided APU is considered inoperative.
14-00	Lavatory Smoke Detection System	C	1	0	(M) (O) For each lavatory, the lavatory smoke detection system maybe inoperative provided: <ul style="list-style-type: none"> a) Lavatory waste receptacle is empty, b) Lavatory door is locked closed and placarded "INOPERATIVE - DO NOT ENTER", and c) Lavatory is used only by crewmembers. <p>NOTE 1: These provisos are not intended to prohibit lavatory use or inspections by crewmembers.</p> <p>NOTE 2: Lavatory smoke detection system is not required for all-cargo operations.</p>
15-00	Baggage Compartment Smoke Detection System	C	1	0	(O) May be inoperative provided procedures are established and used to ensure the associated compartment remains empty, or is verified to contain only empty cargo handling equipment, ballast, (ballast may be loaded in ULDs), and/or Fly Away Kits. NOTE: Operator MELs must define which items are approved for inclusion in the Fly Away Kits, and which materials can be used as ballast.
	1) Airplanes Equipped with Class C or D Baggage Compartment				
15-10	Baggage Compartment Smoke Detector Protective Bar	B	2	0	May be inoperative provided: <ul style="list-style-type: none"> a) Protective bar does not contact the smoke detector, b) Baggage compartment smoke detector is checked before each flight, and c) The higher horizontal net is installed and no load is over the net.



MINIMUM EQUIPMENT LIST

EMBRAER 145LR

AIRCRAFT: EMB-145		REVISION NO: Revisión 07 DATE: 04/07/2017		PAGE: 26-2		
SYSTEM & SEQUENCE NUMBERS		ITEM	1. CAT	2. NUMBER INSTALLED	3. NUMBER REQUIRED FOR DISPATCH	4. REMARKS OR EXCEPTIONS
26 FIRE PROTECTION						
21-02	E1(2) EXTBTLA(B) INOP Caution Messages		B	4	2	(M) One or two messages may be inoperative provided engine fire protection systems A and B are verified operational once each flight day.
22-00	APU Fire Extinguishing System		C	1	0	May be inoperative provided APU is considered inoperative.
22-01	APU EXTBTL INOP Caution Message		C	1	0	(M) May be inoperative provided APU fire protection system is verified operational once each flight day.
			C	1	0	May be inoperative provided APU is considered inoperative.
23-00	Baggage Compartment Fire Extinguisher System		C	1	0	May be inoperative provided cargo compartment remains empty.
23-01	Portable Fire Extinguishers		D	3	2	NOTE: Does not preclude the carriage of empty cargo containers, pallets, ballets, etc. Any in excess of those required by NOM-012-SCT3-2012 may be inoperative or missing provided: a) The inoperative fire extinguisher is tagged inoperative, removed from the installed location, and placed out of sight so it cannot be mistaken for a functional unit, and b) Required distribution is maintained.
25-00	Lavatory Fire Extinguisher Systems		C	1	0	For each lavatory, the lavatory fire extinguisher system may be inoperative provided Lavatory Smoke Detector system operates normally.
			C	1	0	(M) (O) For each lavatory, the lavatory fire extinguisher system may be inoperative provided: a) Lavatory waste receptacle is empty, b) Lavatory door is locked closed and placarded, "INOPERATIVE - DO NOT ENTER", and c) Lavatory is used only by crewmembers. NOTE 1: These provisos are not intended to prohibit lavatory use or inspections by crewmembers. NOTE 2: A lavatory fire extinguisher system is not required for all-cargo operations.
25-01	Galley Fire Extinguisher					Not Installed



MINIMUM EQUIPMENT LIST

EMBRAER 145LR

AIRCRAFT: EMB-145			REVISION NO: Re-Edición DATE: 08/12/2014		PAGE: 27-1
SYSTEM & SEQUENCE NUMBERS			1. CAT	2. NUMBER INSTALLED	
ITEM			3. NUMBER REQUIRED FOR DISPATCH		
27 FLIGHT CONTROLS			4. REMARKS OR EXCEPTIONS		
10-01	Aileron Dampers	C	2	0	(M) May be inoperative provided: a) The affected damper(s) is deactivated, and b) Visual inspection of the affected PCA rod ends and fittings are performed according to the latest approved revision of AD 99-05-04.
14-00	Roll Trim Position Indication	C	1	0	(O) May be inoperative provided: a) Roll trim is verified to be centered before each departure, and b) Yaw trim position indication operates normally.
15-00	Aileron Disconnection Light	C	1	0	(O) May be inoperative provided a check is made before each takeoff to verify that both ailerons are connected.
21-03	Pedal Adjustment Mechanisms	C	2	0	(M) (O) May be inoperative provided rudder pedals can be adjusted to suit individual pilot requirements and is acceptable to the flight crewmember.
24-01	Yaw Trim Position Indications	C	1	0	(O) May be inoperative provided: a) Yaw trim is verified to be centered before each departure, and b) Roll trim position indication operates normally.
35-00	Elevator Disconnection Light	C	1	0	(O) May be inoperative provided a check is made before each takeoff to verify that both elevators are connected.
36-01	SPS/ICE SPEEDS Advisory Message	C	1	0	May be inoperative provided airplane is not operated in known or forecast icing conditions.
		C	1	0	May be inoperative provided AFM abnormal procedure "ADVANCED STALLPROTECTION" is followed.



MINIMUM EQUIPMENT LIST

EMBRAER 145LR

AIRCRAFT: EMB-145			REVISION NO: Revisión 09 DATE: 26/02/2021		PAGE: 27-2
SYSTEM & SEQUENCE NUMBERS			1. CAT	2. NUMBER INSTALLED	
				3. NUMBER REQUIRED FOR DISPATCH	
				4. REMARKS OR EXCEPTIONS	
27 FLIGHT CONTROLS					
36-03	Stick Shakers	B	2	1	
40-00	Main Pitch Trim Switches	C	2	1	One may be inoperative on non-flying pilot's side provided stabilizer trim system operates normally on flying pilot's side.
40-01	Pitch Trim Position Indication	B	1	0	(O) May be inoperative provided stabilizer is set by means of markings on vertical stabilizer prior to each departure.
53-00	Flap Channels	B	2	1	M) (O) One may be inoperative with FLAP LOW SPEED advisory message present provided: a) There are no obstacles in the Takeoff Flight Path above Level Off Height, and b) Motor and brakes of failed channel are deactivated. NOTE: Flaps will operate at half speed
70-00	Electro-mechanical Gust Lock System	C	1	0	M) (O) May be inoperative provided: a) System is deactivated unlocked such that locking pins can not engage the elevator, and b) GUST LOCK amber lights are masked. NOTE: Appropriate measures should be taken to prevent damage from gusts while on the ground.
	1) GUST LOCK Amber Lights	C	2	1	
	2) Gust Lock Lever Movable Stop (Airplanes with SB 145-27-0126)	C	1	0	(M) May be inoperative provided it is secured immovable in one of the edges of the crossbar.
	NOTE: Only applicable for XA-NFP, XA-SFH, XA-EFH, XA-JFH, XA-AFH, XA-MAF & XA-PFL.	C	1	0	May be inoperative provided it has failed immovable in one of the edges of the crossbar.



MINIMUM EQUIPMENT LIST

EMBRAER 145LR

AIRCRAFT:		REVISION NO: Revisión 07		PAGE:	
EMB-145		DATE: 04/07/2017		28-1	
SYSTEM & SEQUENCE NUMBERS	ITEM	1. CAT	2. NUMBER INSTALLED		
			3. NUMBER REQUIRED FOR DISPATCH		
28 FUEL			4. REMARKS OR EXCEPTIONS		
11-02	Sump Drain Valves	C	4	2	(M) One may be inoperative provided: a) There is no evidence of leakage, and b) No water contamination in the other tank is verified before the first departure of each flight day.
11-05	Fueling Receptacle Cap	C	1	0	(M) May be inoperative (missing) provided: a) Refueling receptacle is visually checked for contamination before each refueling, and b) No leakage can be detected after refueling is completed.
14-00	FUEL TK VENT OPEN Message				Not applicable
21-01	Wing Tank Electric Fuel Booster Pumps	C	6	4	(M) (O) One pump per tank may be inoperative provided: a) Remaining two pumps operate normally, b) If the pumps 1C and 2C are inoperative, the message ELECEMERG ABNORMAL must be verified to operate normally before departure, c) Affected electric fuel booster pump is deactivated, and d) AFM limitations regarding unusable fuel are accounted for.
21-02	Wing Tank Electric Fuel Booster Pump Operating Indications	C	6	4	(M) One per side may be inoperative provided associated pump is verified to operate normally before departure.
21-03	Forward Auxiliary Tank Electric Fuel Transfer Pumps				Not applicable.
21-04	Forward Auxiliary Tank Electric Fuel Transfer Pumps Operating Indications				Not applicable.
21-05	Aft Auxiliary Tank Electric Fuel Transfer Pumps				Not applicable.
21-06	Aft Auxiliary Tank Electric Fuel Transfer Pumps Operating Indications				Not applicable.



MINIMUM EQUIPMENT LIST

EMBRAER 145LR

AIRCRAFT:		REVISION NO: Re-Edición		PAGE:	
EMB-145		DATE: 08/12/2014		28-2	
SYSTEM & SEQUENCE NUMBERS		1. CAT	2. NUMBER INSTALLED		
ITEM		3. NUMBER REQUIRED FOR DISPATCH			
28 FUEL		4. REMARKS OR EXCEPTIONS			
21-07	Aft Auxiliary Tank Pressurized Fuel Transfer Systems				Not applicable.
21-08	Aft Auxiliary Tank Pressurized Fuel Transfer System Operating Indications				Not applicable.
21-09	Forward Auxiliary Tank Pressurized Fuel Transfer System Operating Indications				Not applicable.
21-10	Aft Auxiliary Tank Fuel Transfer Operating Indications				Not applicable.
21-11	Ventral Tank Electric Fuel Transfer Pumps				Not applicable.
21-12	Ventral Tank Electric Fuel Transfer Pumps Operating Indications				Not applicable.
22-01	APU FUEL Shutoff Valve	C	1	0	(M) (O) May be inoperative provided: a) APU is not used, and b) Valve is secured closed.
23-00	Pressure Defueling/Refueling System	C	1	0	(M) May be inoperative provided airplane is defueled/refueled by gravity. NOTE 1: If an overfill condition occurs, it must be corrected prior to departure. NOTE 2: Does not preclude ventral or auxiliary tanks refueling by fuel transfer procedures on the ground. NOTE 3: Any fuel leakage at the refueling/defueling adapter must be corrected before departure.



MINIMUM EQUIPMENT LIST

EMBRAER 145LR

AIRCRAFT:		REVISION NO: Re-Edición		PAGE:	
EMB-145		DATE: 08/12/2014		28-3	
SYSTEM & SEQUENCE NUMBERS		1. CAT	2. NUMBER INSTALLED		
ITEM			3. NUMBER REQUIRED FOR DISPATCH		
28 FUEL			4. REMARKS OR EXCEPTIONS		
23-07	Defueling Shutoff Valve(s)	C	1	0	(M) May be inoperative provided valve is secured closed.
23-08	Fuel Quantity Indicator (Refueling panel)	C	1	0	(M) May be inoperative provided airplane is refueled by gravity. NOTE: Does not preclude ventral or auxiliary tanks refueling by fuel transfer procedures on the ground.
40-00	Wing Tank Fuel Quantity Indications (EICAS and MFD)	B	4	2	(O) Indications for one tank may be inoperative provided: a) Fuel quantity in associated tank is verified by an alternate means, and b) Both fuel flow indications and fuel used indications are available, and are monitored throughout flight.
40-01	Forward Auxiliary Tanks Fuel Quantity Indication (EICAS)				Not applicable
40-02	Aft Auxiliary Tank Fuel Quantity Indications (EICAS and MFD)				Not applicable.
40-03	Ventral Tank Fuel Quantity Indications (EICAS and MFD)				Not applicable.
41-01	Ventral Tank Fuel Conditioning Unit(FCU)				Not applicable.
42-01	Direct Quantity Measuring Sticks	C	6	0	(O) May be inoperative provided fuel quantity is determined by other means.
43-00	Fuel Tank Temperature Indication System	C	1	0	May be inoperative provided Total Air Temperature (TAT) is used as an indication of fuel temperature and is limited to -40 degrees C.



MINIMUM EQUIPMENT LIST

EMBRAER 145LR

AIRCRAFT:		REVISION NO: Re-Edición			PAGE:
EMB-145		DATE: 08/12/2014			28-4
SYSTEM & SEQUENCE NUMBERS		1. CAT	2. NUMBER INSTALLED		
ITEM		3. NUMBER REQUIRED FOR DISPATCH			
28 FUEL		4. REMARKS OR EXCEPTIONS			
44-00	FUEL 1 (or 2) LO LEVEL Messages	B	2	0	May be inoperative provided fuel quantity indication is available and is monitored throughout flight.
45-01	E1 (or 2) FUELLO PRESS Messages	B	2	0	(O) May be inoperative provided associated fuel pump automatic function operates normally.
45-02	APU Fuel Low Press Switch	C	1	0	(O) May be inoperative provided APU is not used.
		C	1	0	(O) May be inoperative provided engine 2 fuel low pressure indication is operating normally and is used to check APU fuel pressure.
45-03	FUEL XFER 1(or 2) INOP messages				Not applicable.
45-04	Aft Auxiliary Tank Relief Valves				Not applicable.
45-05	FUSELAGE FUEL IMB Message				Not applicable.
45-06	CHECK ACFT LOAD Message				Not applicable.
45-07	Aft Auxiliary Tank Transfer Isolation Valves				Not applicable.
45-08	Forward Auxiliary Tank Refueling Isolation Valve				Not applicable.
45-09	Aft Auxiliary Tank Refueling Isolation Valve				Not applicable.
45-10	Forward Auxiliary Tank Refueling Ventilation Electrical Shutoff Valves				Not applicable.
45-11	Cross Transfer Shutoff Valve				Not applicable.



MINIMUM EQUIPMENT LIST

EMBRAER 145LR

AIRCRAFT: EMB-145		REVISION NO: Re-Edición DATE: 08/12/2014		PAGE: 28-5	
SYSTEM & SEQUENCE NUMBERS		1. CAT	2. NUMBER INSTALLED		
ITEM		3. NUMBER REQUIRED FOR DISPATCH			
		4. REMARKS OR EXCEPTIONS			
28 FUEL					
45-12	FUEL XFER INOP Message				Not applicable.
45-13	FUEL XFER CRITICAL Message				Not applicable.
45-14	Ventral Tank Fuel Isolation Valve				Not applicable.
45-15	FUEL XFR VTR INOP message				Not applicable.
45-16	Aft Auxiliary Tank Vent Valve				Not applicable.
45-17	Ventral Tank Vent Valve				Not applicable.



MINIMUM EQUIPMENT LIST

EMBRAER 145LR

AIRCRAFT: EMB-145			REVISION NO: Re-Edición DATE: 08/12/2014		PAGE: 29-1
SYSTEM & SEQUENCE NUMBERS			1. CAT	2. NUMBER INSTALLED	
ITEM			3. NUMBER REQUIRED FOR DISPATCH		
29 HYDRAULIC POWER			4. REMARKS OR EXCEPTIONS		
10-02	GSE Couplings (External)	C	4	0	(M) May be inoperative open provided the failed external coupling (or the associated plumbing) is isolated from the hydraulic system.
10-05	Electric Hydraulic Pump Systems				
	1) AUTO Functions	C	2	0	(O) May be inoperative provided: a) Manual function operates normally, and b) Associated electric pump is selected ON for takeoff and landing, and OFF during flight.
	2) Manual Functions	C	2	0	(O) May be inoperative provided AUTO and OFF positions for associated pump selector are verified to operate normally.
10-14	Reservoir Refilling Check Valves	C	2	0	(M) May be inoperative open provided failed valve is removed and plumbing plugged.
		C	2	0	May be inoperative closed.
10-16	Pressure Ground Connection Check Valves	C	2	0	(M) May be inoperative open provided the failed valve is removed and plumbing plugged.
		C	2	0	May be inoperative closed.



MINIMUM EQUIPMENT LIST

EMBRAER 145LR

AIRCRAFT:		REVISION NO: Re-Edición		PAGE:	
EMB-145		DATE: 08/12/2014		29-2	
SYSTEM & SEQUENCE NUMBERS		1. CAT	2. NUMBER INSTALLED		
ITEM			3. NUMBER REQUIRED FOR DISPATCH		
			4. REMARKS OR EXCEPTIONS		
29 HYDRAULIC POWER					
10-19	Engine-driven Pump Pressure Switch (Hydraulic System 1)	C	1	0	(M) (O) May be inoperative provided: a) Pressure indication and electric pump switch operate normally, b) Electric pump is selected ON for takeoff and landing, and OFF during flight, and c) Pressure switch is removed and pressure switch port is plugged in case of fluid leakage.
30-00	Hydraulic Fluid Quantity Indications (including low level warning)	C	2	1	(M) One may be inoperative provided: a) Associated fluid quantity is verified to be normal before each departure, and b) Hydraulic pressure indication is available and is monitored throughout flight.
30-01	Reservoir Quantity Gages	C	2	0	(M) May be inoperative provided: a) Fluid quantity is verified by other means before each departure, and b) Pressure indication is operating normally.
30-02	Hydraulic Pressure Indications	C	2	1	(O) One may be inoperative provided associated hydraulic fluid quantity indication operates normally.
30-04	Electric Pump Pressure Switch (Hydraulic System1)	C	1	0	(M) (O) May be inoperative provided: a) Pressure indication and engine-driven pump switch operate normally, and b) Pressure switch is removed and pressure switch port is plugged in case of fluid leakage.



MINIMUM EQUIPMENT LIST

EMBRAER 145LR

AIRCRAFT: EMB-145			REVISION NO: Re-Edición DATE: 08/12/2014		PAGE: 30-1
SYSTEM & SEQUENCE NUMBERS			1. CAT	2. NUMBER INSTALLED	
ITEM				3. NUMBER REQUIRED FOR DISPATCH	
30 ICE AND RAIN PROTECTION				4. REMARKS OR EXCEPTIONS	
11-00	Wing Anti-icing System	C	1	0	May be inoperative provided airplane is not operated in known or forecast icing conditions.
11-01	Wing Anti-icing Valves	C	2	0	(M) May be inoperative provided: a) Valve is secured closed, and b) Airplane is not operated in known or forecast icing conditions.
11-02	Wing Anti-icing Valve OPEN Light	C	1	0	(M) May be inoperative provided system is verified to operate normally.
		C	1	0	May be inoperative provided airplane is not operated in known or forecast icing conditions.
12-00	Stabilizer Anti-icing System	C	1	0	May be inoperative provided airplane is not operated in known or forecast icing conditions.
12-01	Stabilizer Anti-icing Valve	C	1	0	(M) May be inoperative provided: a) Valve is secured closed, and b) Airplane is not operated in known or forecast icing conditions.
12-02	Stabilizer Anti-icing Valve OPEN Light	C	1	0	(M) May be inoperative provided system is verified to operate normally.
		C	1	0	May be inoperative provided airplane is not operated in known or forecast icing conditions.

AIRCRAFT:		REVISION NO: Revisión 09		PAGE:	
EMB-145		DATE: 26/02/2021		30-2	
SYSTEM & SEQUENCE NUMBERS	ITEM	1. CAT	2. NUMBER INSTALLED		
			3. NUMBER REQUIRED FOR DISPATCH		
			4. REMARKS OR EXCEPTIONS		
30 ICE AND RAIN PROTECTION					
21-00	Engine Anti-icing Systems	B	2	1	<p>May be inoperative for operation in VMC from sunrise to sunset provided:</p> <ul style="list-style-type: none"> a) Affected A/I pushbutton is positioned to OFF prior to departure, and b) Airplane is not operated in known or forecast icing conditions. <p>NOTE: The message ENG A/ICE OVERPRES may be present.</p>
		B	2	0	<p>May be inoperative for day VMC provided:</p> <ul style="list-style-type: none"> a) Affected A/I pushbutton is positioned to OFF prior to departure, and b) Airplane is not operated in known or forecast icing conditions. <p>NOTE: The message ENG A/ICE OVERPRES may be present.</p>
21-01	Engine Anti-icing Valves	C	2	0	<p>(M) (O) May be inoperative provided:</p> <ul style="list-style-type: none"> a) Valve is secured open, and b) AFM performance penalties are applied. <p>NOTE: On airplanes equipped with EICAS version 16.5 or subsequent, the message ENGA/ICE OVERPRES may be present.</p>
		C	2	1	<p>One may be inoperative provided airplane is not operated in known or forecast icing conditions.</p>
21-02	Engine Anti-icing Valve OPEN Light	C	2	1	<p>(M) One may be inoperative provided system is verified to operate normally.</p>
		C	2	1	<p>One may be inoperative provided airplane is not operated in known or forecast icing conditions.</p>
31-00	Pitot/Static Heating Systems	C	3	2	<p>(M) One may be inoperative provided:</p> <ul style="list-style-type: none"> a) Standby and remaining pitot/static heating systems operate normally, and b) Airplane is not operated in visible moisture or in known or forecast icing conditions. <p>Note: If not have this equipment Aircraft is not Allowed to fly into RVSM according to NOM-091-SCT3-2004.</p>
31-03	Pitot Lines Heater	C	2	1	
32-01	AOA Sensor Heating Systems	B	2	1	<p>One may be inoperative provided airplane is not operated in known or forecast icing conditions.</p>

AIRCRAFT: EMB-145			REVISION NO: Revisión 09 DATE: 26/02/2021		PAGE: 30-3
SYSTEM & SEQUENCE NUMBERS			1. CAT	2. NUMBER INSTALLED	
ITEM			3. NUMBER REQUIRED FOR DISPATCH		
			4. REMARKS OR EXCEPTIONS		
30 ICE AND RAIN PROTECTION					
33-01	TAT Probe Heating Systems	C	2	1	One may be inoperative provided airplane is not operated known or forecast icing conditions.
41-00	Windshield Wipers	C	2	0	May be inoperative provided airplane is not operated in precipitation within 5 nautical miles of the airport of takeoff or intended landing.
1)	Low Speed	C	2	0	May be inoperative provided high speed operates normally.
2)	High Speed	C	2	0	May be inoperative provided low speed operates normally.
3)	Parking Mode	C	2	0	(O) May be inoperative provided blades can be positioned providing an acceptable field of vision to flight crew.
4)	Timer Mode	C	2	0	
41-04	Rain Repellent Coating	C	2	0	May be inoperative provided: <ul style="list-style-type: none"> a) No precipitation is forecasted during a period from 1 hour before until 1 hour after the estimated time of departure and arrival at the takeoff and destination airports, and b) Affected system is not part of the equipment required for the intended operation.
		B	2	1	One may be degraded on pilot monitoring side provided: <ul style="list-style-type: none"> a) Visibility for the flightcrew is acceptable, and b) Affected system is not part of the equipment required for the intended operation.
42-02	Windshield Heating Systems	C	2	1	(M) One may be inoperative provided: <ul style="list-style-type: none"> a) Affected windshield heating system is deactivated, and b) Airplane is not operated in known or forecast icing conditions.
80-00	Ice Detectors	C	2	1	
		B	2	0	(O) May be inoperative provided alternate procedures are established and used.
81-01	Clear Ice Detector System	C	1	0	May be inoperative provided wing upper surface is verified to be free of clear ice prior to departure.
	1) Clear Ice Indication	C	2	0	(O) May be inoperative provided the EICAS clear ice messages operate normally.



MINIMUM EQUIPMENT LIST

EMBRAER 145LR

AIRCRAFT:		REVISION NO: Revisión 07		PAGE:	
EMB-145		DATE: 04/07/2017		31-1	
SYSTEM & SEQUENCE NUMBERS		1. CAT	2. NUMBER INSTALLED		
ITEM		3. NUMBER REQUIRED FOR DISPATCH			
31 INDICATING/RECORDING SYSTEMS		4. REMARKS OR EXCEPTIONS			
21-01	Clocks				
	1) Copilot's Clock	C	1	0	May be inoperative provided pilot's clock operate normally
	2) Pilot's clock	A	1	1	Note: Requirement complied as demanded in NOM-012-SCT3-2012
30-01	Flight Data Recorder (FDR) System	A	1	1	Note: Requirement complied as demanded in NOM-022-SCT3-2011 may be inoperative provided the MiniQAR operates normally (only in case of airplanes XA-RHF, XA-BPK, XA-MFH).
	1) FDR Recording Parameters required by NOM-022-SCT3-2011	A	1	0	May be inoperative provided: a) Cockpit Voice Recorder (CVR) operates normally, and b) Repairs are made within 20 calendar days.
	2) FDR Recording Parameters not required by NOM-022-SCT3-2011	A	1	0	May be inoperative provided repairs are made prior to the completion of the next heavy maintenance visit.



MINIMUM EQUIPMENT LIST

EMBRAER 145LR

AIRCRAFT:		REVISION NO: 01		PAGE:	
EMB-145		DATE: 20/04/2015		31-2	
SYSTEM & SEQUENCE NUMBERS	ITEM	1. CAT	2. NUMBER INSTALLED		
			3. NUMBER REQUIRED FOR DISPATCH		
31 INDICATING/RECORDING SYSTEMS			4. REMARKS OR EXCEPTIONS		
33-02	Quick Access Recorder (QAR)	D	1	0	According with Supplemental Type Certificate ST02472AT EMB 145 miniQAR
42-02	Integrated Computer Configuration Modules (IM-600)	B	2	1	One may be inoperative with the EICAS message IC 1(2) CONFIG FAIL displayed provided the EICAS messages CONFIG MISMATCH or CHK ICONFIG are not displayed.
51-00	Aural Warning Unit 1) Channels	C	2	1	
51-02	MASTER Warning Lights/Buttons 1) Lights	C	2	1	One may be inoperative provided master warning aural alert operates normally.
	2) Alarm Cancel Functions	C	2	1	
51-03	MASTER Caution Lights/Buttons 1) Lights	C	2	1	One may be inoperative provided master caution aural alert operates normally.
	2) Alarm Cancel Functions	C	2	1	



MINIMUM EQUIPMENT LIST

EMBRAER 145LR

AIRCRAFT:		REVISION NO: Re-Edición		PAGE:	
EMB-145		DATE: 08/12/2014		32-1	
SYSTEM & SEQUENCE NUMBERS		1. CAT	2. NUMBER INSTALLED		
ITEM			3. NUMBER REQUIRED FOR DISPATCH		
			4. REMARKS OR EXCEPTIONS		
32 LANDING GEAR					
33-02	Landing Gear Control Lever Latch System	B	1	0	(M) (O) May be inoperative in the latched position provided: a) Downlock release mechanism operates normally, and b) LG AIR/GND FAIL message is not present.
40-01	Brake Temperature Indications	C	4	3	(M) One may be inoperative provided the affected Brake Temperature Sensor is deactivated.
		C	4	0	(M) (O) May be inoperative provided: a) Affected Brake Temperature Sensors are deactivated, and b) Quick Turnaround Chart in AFM is complied with.
41-08	Brake Pressure Transducers	B	4	3	(M) One may be inoperative with the BRAKE DEGRADED caution message present provided: a) Only the respective PRESS TRANSDUCER FAIL message is present on the brake system portion of the CMC, b) External leakage is not present, and c) Affected brake pressure transducer is deactivated.
44-05	Accumulator Low Pressure Switch	C	1	0	(M) May be inoperative provided accumulator charge is verified to be normal once each flight day.



MINIMUM EQUIPMENT LIST

EMBRAER 145LR

AIRCRAFT:		REVISION NO: Re-Edición		PAGE:	
EMB-145		DATE: 08/12/2014		32-2	
SYSTEM & SEQUENCE NUMBERS		1. CAT	2. NUMBER INSTALLED		
ITEM			3. NUMBER REQUIRED FOR DISPATCH		
			4. REMARKS OR EXCEPTIONS		
32 LANDING GEAR					
44-07	BRAKE ON Lights				
	1) Cockpit Light	B	1	0	(M) May be inoperative provided emergency/parking brake system operates normally.
	2) Ramp Light	C	1	0	
49-00	Brake Assembly Wear Indicator	C	8	4	(M) One per brake assembly may be inoperative.
50-00	External Steering Disengagement Switch				Not installed.
50-02	Control Wheel Steering Disengage Buttons	C	2	1	(M) Pilot Flying's disengage button may be inoperative provided Pilot Not Flying's disengage button operates normally.
60-00	Landing Gear Proximity Switches	B	19	13	(M) One up lock proximity switch and one down lock proximity switch maybe inoperative in each landing gear leg.
					NOTE: Proximity switches include: air/ground, up lock, downlock, 7-degree steering, and nose landing gear door sequence.



MINIMUM EQUIPMENT LIST

EMBRAER 145LR

AIRCRAFT:		REVISION NO: Revisión 07		PAGE:	
EMB-145		DATE: 04/07/2017		33-1	
SYSTEM & SEQUENCE NUMBERS		1. CAT	2. NUMBER INSTALLED		
ITEM			3. NUMBER REQUIRED FOR DISPATCH		
33 LIGHTS			4. REMARKS OR EXCEPTIONS		
10-00	Cockpit/Flight Deck/Flight Compartment and Instrument Lighting Systems	C	-	-	Individual lights may be inoperative provided remaining lights are: <ul style="list-style-type: none"> a) Sufficient to clearly illuminate all required instruments, controls, another devices for which they are provided, b) Positioned so that direct rays are shielded from flight crewmembers' eyes, and c) Lighting configuration and intensity is acceptable to the flight crew.
20-00	Cabin Interior Illumination System 1) Aircraft Without Photoluminescent Emergency Escape Path Marking System	C	-	-	Individual lights may be inoperative provided remaining lighting is sufficient for cabin attendant to perform assigned duties.
21-02	Cockpit Sterile Light	C	1	0	(O) May be inoperative provided alternate procedures are established and used
23-00	Passenger Lighted Information Signs	C	36	-	(M) May be inoperative provided: <ul style="list-style-type: none"> a) Associated passenger seat or lavatory is not occupied from which a passenger lighted information sign is not readily legible, and b) Associated seat or lavatory must be blocked and placarded "DO NOT OCCUPY". NOTE: These provisos are not intended to prohibit lavatory use or inspections by crewmembers.
		C	36	-	(O) May be inoperative and associated passenger seat or lavatory may be occupied provided: <ul style="list-style-type: none"> a) PA system operates normally, and b) PA system is used to notify passengers and cabin crew when associated sign(s) are placed on or off.
26-00	Courtesy and Stairs Lighting System	C	1	0	May be inoperative provided sufficient light is available at the stairs region.



MINIMUM EQUIPMENT LIST

EMBRAER 145LR

AIRCRAFT:		REVISION NO: Revisión 09			PAGE:	
EMB-145		DATE: 26/02/2021			33-2	
SYSTEM & SEQUENCE NUMBERS		1. CAT	2. NUMBER INSTALLED			
ITEM			3. NUMBER REQUIRED FOR DISPATCH			
			4. REMARKS OR EXCEPTIONS			
33 LIGHTS						
30-00	Compartment Lights (Nose, Tail, etc.)	C	1	0		
41-00	Landing Lights	C	3	2	One may be inoperative for night operations.	
		C	3	0	May be inoperative for operations from sunrise to sunset .	
	1) Nose Landing Gear Automatic Extinguishing Function	C	1	0	(O) May be inoperative provided light is manually turned off after gear retraction.	
42-00	Taxi Light	C	2	1		
		C	2	0	May be inoperative provided nose landing light is operating normally.	
		C	2	0	May be inoperative for operations from sunrise to sunset .	
	1) Automatic Extinguishing Function	C	1	0	(O) May be inoperative provided light is manually turned off after gear retraction.	
43-00	Navigation Lights	C	6	4	(M) Any light may be inoperative provided one green light, one red light and two white lights operate normally.	
		C	6	0	May be inoperative for operations from sunrise to sunset .	
	1) Tail Boom White Nav Light				Deleted Rev.18	
44-00	Wing Inspection Lights	C	2	0	May be inoperative provided ground deicing procedures do not require their use.	
46-00	Logo Lights	D	2	0		

47-03	Strobe Lights	C	3	0	May be inoperative provided red beacon operates normally .	



MINIMUM EQUIPMENT LIST

EMBRAER 145LR

AIRCRAFT:		REVISION NO: Revisión 09		PAGE:	
EMB-145		DATE: 26/02/2021		33-3	
SYSTEM & SEQUENCE NUMBERS		1. CAT	2. NUMBER INSTALLED		
ITEM		3. NUMBER REQUIRED FOR DISPATCH			
33 LIGHTS		4. REMARKS OR EXCEPTIONS			
47-05	Red Beacons Lights	C	2	0	(O) May be inoperative provided: a) Beacon switch is positioned to ON prior to engine start, and b) Strobe lights operate normally.
48-00	Baggage Door External Light	C	1	0	NOTE: The rotating beacon switch should be positioned to ON before engine start to turn the FDR on.
50-00	Emergency Lighting System (Battery-Powered)				
	1) External Lights	C	6	0	May be inoperative for operations from sunrise to sunset .
	2) Floor Proximity Strips	C	8	0	Up to two individual strips may be inoperative provided: a) They are not adjacent, and b) They are not used as an exit locator (amber light).
50-01	Photoluminescent Floor Proximity Emergency Escape Path Marking				Not Installed



MINIMUM EQUIPMENT LIST

EMBRAER 145LR

AIRCRAFT: EMB-145			REVISION NO: 03 DATE: 01/09/2015		PAGE: 34-1
SYSTEM & SEQUENCE NUMBERS			1. CAT	2. NUMBER INSTALLED	
ITEM			3. NUMBER REQUIRED FOR DISPATCH		
			4. REMARKS OR EXCEPTIONS		
34 NAVIGATION					
22-01	Main Panel Displays	B	5	4	(M) Non-flying pilot's MFD (inboard display unit) may be inoperative.
	1) MFD Bezel	C	2	1	One may be inoperative provided opposite MFD works normally.
22-02	TAT Indications	C	2	1	
22-03	SAT Indications	C	2	1	
24-01	Standby Attitude Indication (on Integrated Standby Instrument (ISIS) or on dedicated instrument)				Not installed.
24-02	Standby Barometric pressure (STD) Button on ISIS				Not installed
25-00	Head-Up Guidance System (HGS)				Not installed.



MINIMUM EQUIPMENT LIST

EMBRAER 145LR

AIRCRAFT:		REVISION NO: Re-Edición		PAGE:	
EMB-145		DATE: 08/12/2014		34-2	
SYSTEM & SEQUENCE NUMBERS		1. CAT	2. NUMBER INSTALLED		
ITEM		3. NUMBER REQUIRED FOR DISPATCH			
34 NAVIGATION		4. REMARKS OR EXCEPTIONS			
25-01	Standby Magnetic Compass	B	1	0	(O) May be inoperative provided any combination of three gyro or INS (IRU) stabilized Compass Systems are operative.
		B	1	0	Note: Requirement complied as demanded in NOM-012-SCT3-2012. (O) May be inoperative provided: a) Any combination of two gyro or INS (IRU) stabilized Compass Systems operate normally, and b) Airplane is operated with Dual Independent Navigation Capability and under Positive Radar Control by ATC on the enroute portion of the flight.
		B	1	0	(O) May be inoperative for flights that are entirely within areas of magnetic unreliability provided at least two Stabilized Directional Gyro Systems are installed, operate normally, and used in conjunction with approved Free Gyro Navigation Techniques.
27-00	Inertial Reference System (IRS)				Not installed.
27-05	IRS MSU Annunciators Lights				
	1) ALIGN Annunciator				Not installed.
	2) FAULT Annunciator				Not installed.
	3) ON BATT Annunciator				Not installed.
	4) NO AIR Annunciator				Not installed.
	5) NAV RDY Annunciator				Not installed.
	6) BATT FAIL Annunciator				Not installed.



MINIMUM EQUIPMENT LIST

EMBRAER 145LR

AIRCRAFT:		REVISION NO: Re-Edición		PAGE:	
EMB-145		DATE: 08/12/2014		34-3	
SYSTEM & SEQUENCE NUMBERS		1. CAT	2. NUMBER INSTALLED		
ITEM		3. NUMBER REQUIRED FOR DISPATCH			
34 NAVIGATION		4. REMARKS OR EXCEPTIONS			
31-00	Radio Altimeter System				
	1) Single Radio Altimeter Installation	A	1	0	M) (O) May be inoperative provided: a) Approach minimums or operating procedures do not require its use, b) GPWS/EGPWS is considered inoperative, c) TCAS is considered inoperative, d) Radio altimeter is deactivated, and e) Repairs are made within two flight days.
	2) Dual Radio Altimeter Installation	C	2	1	(M) (O) Radio altimeter 2 may be inoperative provided: a) Approach minimums or operating procedures do not require its use, and b) Radio altimeter 2 is deactivated.
		A	2	0	(M) (O) Radio altimeter 1 or both maybe inoperative provided: a) Approach minimums or operating procedures do not require its use, b) GPWS/EGPWS is considered inoperative, c) TCAS is considered inoperative if both radio altimeters are inoperative, d) Affected radio altimeter(s) is deactivated, and e) Repairs are made within two flight days.
	3) Dual Radio Altimeter Installation (With SB145-34-0083 or SB145LEG-34-0010 Incorporated	C	2	1	(M)(O) May be inoperative provided: a) Approach minimums or operating procedures do not require its use, and b) Affected Radio Altimeter is deactivated.
		A	2	0	M)(O)Both may be inoperative provided: a) Approach minimums or operating procedures do not require their use, b) GPWS/EGPWS is considered inoperative, c) TCAS is considered inoperative, d) Radio Altimeters are deactivated, and e) Repairs are made within two flight days



MINIMUM EQUIPMENT LIST

EMBRAER 145LR

AIRCRAFT:		REVISION NO: Re-Edición		PAGE:	
EMB-145		DATE: 08/12/2014		34-4	
SYSTEM & SEQUENCE NUMBERS		1. CAT	2. NUMBER INSTALLED		
ITEM			3. NUMBER REQUIRED FOR DISPATCH		
34 NAVIGATION			4. REMARKS OR EXCEPTIONS		
31-01	Altitude Alerter Function	A	1	0	(O) May be inoperative provided: a) Autopilot with Altitude Hold and Altitude Capture operates normally, b) Enroute operations, i.e, RVSM, do not require its use, c) Airplane does not depart from a designated airport (as listed in the operator's MEL) where repair or replacement can be made, and d) Repairs are made within 3 flight days. Note: If not have this equipment Aircraft is not Allowed to fly into RVSM according to NOM-091-SCT3-2004.
31-02	Altitude Preselect Function	A	1	0	(O) may be inoperative provided: a) Autopilot with Altitude Hold and Altitude Capture operates Normally, b) Enroute operations, i.e, RVSM, do not require its use, c) Alternate procedures are established and used, d) Flight Level Change (FLC)Mode is not used, e) Go Around buttons on the Thrust levers are not used, f) Altitude alerter function is not used, g) Airplane does not depart from a designated airport (as listed in the operator's MEL) where repair or replacement can be made, and h) Repairs are made within 3 flight days. Note: If not have this equipment not be fly in RVSM. As required by NOM-091-SCT3-2004.
32-00	VOR/ILS Systems	C	2	1	As required by NOM-012-SCT3-2012.
	1) Instrument Landing System (ILS)	C	2	1	May be inoperative provided approach minimums do not require its use.
	2) Marker Beacon	C	2	0	May be inoperative provided approach minimums do not require its use.



MINIMUM EQUIPMENT LIST

EMBRAER 145LR

AIRCRAFT:		REVISION NO: Revisión 07		PAGE:	
EMB-145		DATE: 04/07/2017		34-5	
SYSTEM & SEQUENCE NUMBERS		1. CAT	2. NUMBER INSTALLED		
ITEM		3. NUMBER REQUIRED FOR DISPATCH			
34 NAVIGATION		4. REMARKS OR EXCEPTIONS			
41-00	Enhanced Ground Proximity Warning System (EGPWS)				
	1) GPWS	A	1	0	(O) May be inoperative provided: a) Alternate procedures are established and used, and b) Repairs are made within one flight days.
	a) Modes 1-4	A	4	0	Note: Requirement complied as demanded in NOM-070-SCT3-2010. (O) May be inoperative provided: a) Alternate procedures are established and used, and b) Repairs are made within one flight days.
	b) Test Mode	A	1	0	May be inoperative provided: a) GPWS is considered inoperative, and b) Repairs are made within one flight days.
	c) Glideslope Deviation(s) (Mode 5)	C	2	1	
		B	2	0	
	d) Advisory Callouts	B	1	0	(O) May be inoperative provided alternate procedures are established and used.
		C	1	0	(O) May be inoperative provided: a) Advisory callout not required by local authorities, and b) Alternate procedures are established and used.
					(Continued)



MINIMUM EQUIPMENT LIST

EMBRAER 145LR

AIRCRAFT:		REVISION NO: Re-Edición		PAGE:	
EMB-145		DATE: 08/12/2014		34-6	
SYSTEM & SEQUENCE NUMBERS		1. CAT	2. NUMBER INSTALLED		
ITEM			3. NUMBER REQUIRED FOR DISPATCH		
			4. REMARKS OR EXCEPTIONS		
34 NAVIGATION					
41-00	Enhanced Ground Proximity Warning System (EGPWS)				
	1) GPWS (Cont'd)				
	e) Windshear Mode (Reactive)	B	1	0	(O) May be inoperative provided alternate procedures are established and used.
		C	1	0	NOTE: Operator's alternate procedures should include reviewing windshear avoidance and windshear recovery procedures. (O) May be inoperative provided: a) Alternate procedures are established and used, and b) Windshear Detection and Avoidance System (Predictive) operates normally.
	2) Terrain System – Forward Looking Terrain Avoidance (FLTA And Premature Descent Alert (PDA)Functions	B	1	0	(O) May be inoperative provided alternate procedures are established and used.
	3) Terrain Displays	C	2	1	
		B	2	0	Not Installed.
	4) Runway Awareness & Advisory System (RAAS)				
41-01	Windshear Detection and Guidance Systems				Deleted, Rev 5. (Included in item41-00.)
41-02	Steep Approach Function	C	1	0	(M) May be inoperative provided: a) Steep approach is deactivated, and b) Steep approach procedure is not performed.



MINIMUM EQUIPMENT LIST

EMBRAER 145LR

AIRCRAFT:		REVISION NO: Revisión 09		PAGE:	
EMB-145		DATE: 26/02/2021		34-7	
SYSTEM & SEQUENCE NUMBERS		1. CAT	2. NUMBER INSTALLED		
ITEM			3. NUMBER REQUIRED FOR DISPATCH		
			4. REMARKS OR EXCEPTIONS		
34 NAVIGATION					
42-00	Weather Radar System	C	1	0	As required by NOM-012-SCT3-2012.
	1) Stabilization Function	B	1	0	(M) May be inoperative provided: <ul style="list-style-type: none"> a) Antenna sweep is parallel to aircraft pitch axis, and b) Antenna tilt operates normally. Not installed.
	2) Lightning Sensor System				Not installed.
	3) Control Panels (Only airplanes equipped with two panels)				Not installed.
42-01	Stormscope				Not installed.
43-00	Traffic Alert and Collision Avoidance System (TCAS II)	B	1	0	(M) May be inoperative provided: <ul style="list-style-type: none"> a) System is deactivated and secured, and b) Enroute or approach procedures do not require its use.
		C	1	0	(M) (O) May be inoperative provided: <ul style="list-style-type: none"> a) Not required by the national aviation authority, b) System is deactivated and secured, and c) Enroute or approach procedures do not require its use.
	1) Combined Traffic Alert (TA) and Resolution Alert (RA)Dual Display System(s)	C	2	1	May be inoperative on the non-flying pilot side provided: <ul style="list-style-type: none"> a) TA and RA visual display is operative on flying pilot side, and b) TA and RA audio function is operative on flying pilot side.
(Continued)					

AIRCRAFT:		REVISION NO: Revisión 09			PAGE:
EMB-145		DATE: 26/02/2021			34-8
SYSTEM & SEQUENCE NUMBERS	ITEM	1. CAT	2. NUMBER INSTALLED		
			3. NUMBER REQUIRED FOR DISPATCH		
34 NAVIGATION			4. REMARKS OR EXCEPTIONS		
43-00	Traffic Alert and Collision Avoidance System (Cont'd)	C	2	1	May be inoperative on non-flying pilot side.
	2) Resolution Advisory (RA) Display System(s)	C	2	0	(O) May be inoperative provided: a) Traffic Alert (TA) visual display and audio functions are operative, b) TA only mode is selected by the crew, and c) Enroute or approach procedures do not require its use.
	3) Traffic Alert Display System(s)	C	2	0	NOTE: Normal ADS-B function may be effected by above relief. (O) May be inoperative provided: a) RA visual display and audio functions are operative, and b) Enroute or approach procedures do not require its use.
51-00	Distance Measuring Equipment (DME)	D	2	0	Any in excess of those required by NOM-012-SCT3-2012 may be inoperative.
52-00	ATC Transponders and Automatic Altitude Reporting Systems	B	2	0	May be inoperative provided: a) Enroute operations do not require its use, and b) Prior to flight, approval is obtained from ATC facilities having jurisdiction over the planned route of flight.
		D	2	1	NOTE 1: If not have this equipment Aircraft is not Allowed to fly into RVSM according to NOM-091-SCT3-2004. NOTE 2: Normal ADS-B function may be effected by above relief. Any in excess of those required by NOM-003-SCT3-2010 may be inoperative.
1) ***	Elementary and Enhanced Downlink Aircraft Reportable Parameters Not Required by state legislation.	A	-	0	May be inoperative provided: a) Operations do not require its use, and b) Repairs are made prior to completion of the next heavy maintenance visit.



MINIMUM EQUIPMENT LIST

EMBRAER 145LR

AIRCRAFT:		REVISION NO: Revision 09		PAGE:	
EMB-145		DATE: 26/02/2021		34-9	
SYSTEM & SEQUENCE NUMBERS	ITEM	1. CAT	2. NUMBER INSTALLED		
			3. NUMBER REQUIRED FOR DISPATCH		
34 NAVIGATION			4. REMARKS OR EXCEPTIONS		
2) ***	ADS-B Out Extended Squitter Transmissions NOTE: only for XA-NFP, XA-AFH and XA-SFH aircrafts. (Cont'd)	C	-	0	(O) May be inoperative provided: a) Alternate procedures are established and used, b) Authorization is obtained from ATC facilities having jurisdiction over planned route of flight, and c) It is not required by the territory's national aviation authority. NOTE 1: for operational procedure refers AOM 2-18-95 p. 1thru 6. NOTE 2: NOTE: Any ADS-B function that operates normally may be used.
		C	-	1	One must be operative as required by jurisdictional national authority. NOTE: Any ADS-B function that operates normally may be used.
53-00	ADF System	C	2	0	As required by NOM-012-SCT3-2012.
54-00	XM Weather System				Not installed
56-00	Global Positioning System	C	1	0	(O) May be inoperative provided alternate procedures are established and used. NOTE: Normal ADS-B function may be effected by above relief.
		C	1	0	May be inoperative provided procedures do not require its use. NOTE: Normal ADS-B function may be effected by above relief.

(Continued)



MINIMUM EQUIPMENT LIST

EMBRAER 145LR

AIRCRAFT: EMB-145		REVISION NO: Revision 09 DATE: 26/02/2021		PAGE: 34-10	
SYSTEM & SEQUENCE NUMBERS		1. CAT	2. NUMBER INSTALLED		
ITEM			3. NUMBER REQUIRED FOR DISPATCH		
			4. REMARKS OR EXCEPTIONS		
34 NAVIGATION					
60-00	Flight Management System	C	1	1	One is required if IRS is used as primary navigation or attitude source.
		C	1	0	(O) May be inoperative provided alternate procedures are established and used.
		D	1	0	NOTE: Normal ADS-B function may be effected by above relief. May be inoperative provided procedures do not require its use. NOTE 1: Airplanes equipped with EGPWS and operating without FMS will lose the Terrain Clearance Floor mode. A TERRAIN INOP message will be presented on the EICAS.
	1) Navigation Databases	A	1	0	NOTE 2: Normal ADS-B function may be effected by above relief. (O) May be out of currency provided: a) Operations do not require its use, b) It is not used in a primary navigation system required by national aviation legislation c) Alternate procedures are developed and used, d) The ICAO flight plan is updated (as required), to notify ATC of the navigation equipment status of the aircraft and, e) It is repaired within 10 flight-days.
	2) Joystick Controller	C	1	0	NOTE 1: Normal ADS-B function may be effected by above relief. NOTE 2: An out-of-currency or out-of-date navigation database is not authorized MMEL relief per national aviation legislation.

0



MINIMUM EQUIPMENT LIST

EMBRAER 145LR

AIRCRAFT:		REVISION NO: Revisión 03			PAGE:
EMB-145		DATE: 01/09/2015			35-1
SYSTEM & SEQUENCE NUMBERS		1. CAT	2. NUMBER INSTALLED		
ITEM		3. NUMBER REQUIRED FOR DISPATCH			
		4. REMARKS OR EXCEPTIONS			
35 OXYGEN					
11-01	Crew Mask Stowage Boxes				Deleted, Rev 8.
11-00	Oxygen Pressure Indication Systems	B	2	1	(O) One may be inoperative provided an approved procedure is used before each departure to ensure that oxygen supply is at or above minimum required for flight.
11-03	Oxygen Cylinder Pressure Relief Disc (Green Disc)	C	1	0	May be missing or broken provided flight crew oxygen system operates normally
20-00	Passenger Oxygen System	B	1	0	(O) May be inoperative provided: <ul style="list-style-type: none"> a) Altitude limitations and portable oxygen supplies comply with regulations requirements, b) All air conditioning packs operate normally, c) Pressurization system operates normally, and d) Passengers are appropriately briefed.
		B	1	0	May be inoperative provided flight is conducted at or below 10,000 ft. MSL.
	1) Automatic Presentation System	C	1	0	(M) (O) May be inoperative provided: <ul style="list-style-type: none"> a) Manual deployment system operates normally, and b) Flight is conducted at or below FL 300.
	2) Passenger Dispensing Units	C	37	0	(M) (O) May be inoperative without flight altitude restriction provided: <ul style="list-style-type: none"> a) Affected seats are placarded and blocked to prevent occupancy, and b) Units operate normally at all usable lavatory and flight attendant locations.
20-05	Passenger Oxygen System Door -Manual Opening Tool	C	2	1	
		C	2	0	(O) May be inoperative or missing provided alternate procedures are established and used.



MINIMUM EQUIPMENT LIST

EMBRAER 145LR

AIRCRAFT:		REVISION NO: Revisión 09		PAGE:	
EMB-145		DATE: 26/02/2021		35-2	
SYSTEM & SEQUENCE NUMBERS	ITEM	1. CAT	2. NUMBER INSTALLED		
			3. NUMBER REQUIRED FOR DISPATCH		
35 OXYGEN			4. REMARKS OR EXCEPTIONS		
30-01	Portable Oxygen Units (Bottle and Mask)	C	2	1	(M) Any in excess of those required by NOM-012-SCT3-2012 may be unserviceable or missing provided: <ul style="list-style-type: none"> a) Required distribution of serviceable bottles is maintained throughout airplane, and b) Bottles not properly serviced are replaced, serviced, or removed at the next available maintenance facility.
30-03	Protective Breathing Equipment (PBE)	D	3	2	Any in excess of those required by 14 CFR may be inoperative or missing provided: <ul style="list-style-type: none"> a) Inoperative PBE remains in a certified location or is removed from the aircraft, a) Location placarding is removed or obscured, and a) Required distribution is maintained. <p>NOTE: Inoperative PBE units removed from a certified location, or removed from the aircraft, are subject to CO AV-17.5/07 dangerous goods regulations.</p>



MINIMUM EQUIPMENT LIST

EMBRAER 145LR

AIRCRAFT:		REVISION NO: Re-Edición		PAGE:	
EMB-145		DATE: 08/12/2014		36-1	
SYSTEM & SEQUENCE NUMBERS	ITEM	1. CAT	2. NUMBER INSTALLED		
			3. NUMBER REQUIRED FOR DISPATCH		
36 PNEUMATIC			4. REMARKS OR EXCEPTIONS		
11-05	Engine Bleed Systems	C	2	1	(M) (O) Left engine bleed system maybe inoperative provided: a) Left engine bleed valve is secured closed, b) APU bleed is operating normally and supplying bleed air, c) Crossbleed valve is closed and d) Airplane is not operated in known or forecast icing conditions.
		C	2	1	(M) (O) Left engine bleed system maybe inoperative provided: a) Left engine bleed valve is secured closed, b) When APU is not supplying bleed air, flight is conducted at or below FL 250, and c) Airplane is not operated in known or forecast icing conditions.
		C	2	1	(M) (O) Right engine bleed system maybe inoperative provided: a) Right engine bleed valve is secured closed, b) Flight is conducted at or below FL 250, and c) Airplane is not operated in known or forecast icing conditions.
		C	2	0	(M) (O) May be inoperative provided: a) Engine bleed valves are secured closed, c) APU bleed is operating normally and supplying bleed air, d) Flight is conducted at or below 18000 ft MSL, and e) Airplane is not operated in known or forecast icing conditions.
NOTE: For airplanes equipped with ISIS, at least Pack 2 and Recirculation Fan 2 must be operative or Pack 1 must be operative.					
(Continued)					



MINIMUM EQUIPMENT LIST

EMBRAER 145LR

AIRCRAFT:		REVISION NO: Revisión 07		PAGE:	
EMB-145		DATE: 04/07/2017		36-2	
SYSTEM & SEQUENCE NUMBERS		1. CAT	2. NUMBER INSTALLED		
ITEM		3. NUMBER REQUIRED FOR DISPATCH			
		4. REMARKS OR EXCEPTIONS			
36 PNEUMATIC					
11-05	Engine Bleed Systems (Cont'd)	C	2	0	(M) (O) May be inoperative provided: a) Engine bleed valves are secured closed, b) Flight is conducted at or below 10000 ft MSL, c) Flight is conducted in an unpressurized configuration, d) Airplane is not operated in known or forecast icing conditions, and e) Ambient temperature on the ground is below ISA +21degrees C. NOTE: This configuration is not applicable for airplanes equipped with ISIS.
11-10	Air Conditioning Panel Air Button Red Leak Indication	B	2	0	(M)May be inoperative provided associated BLD LEAK EICAS message operates normally.
12-01	APU Bleed System	C	1	0	(M) May be inoperative provided: a) APU bleed shutoff valve is secured closed, and b) APU Bleed is selected off and not used.
20-00	BLD APU LEAK Warning Message	C	1	0	May be inoperative provided APU is considered inoperative.



MINIMUM EQUIPMENT LIST

EMBRAER 145LR

AIRCRAFT:		REVISION NO: Revisión 09		PAGE:	
EMB-145		DATE: 26/02/2021		38-1	
SYSTEM & SEQUENCE NUMBERS		1. CAT	2. NUMBER INSTALLED		
ITEM		3. NUMBER REQUIRED FOR DISPATCH			
38 WATER/WASTE		4. REMARKS OR EXCEPTIONS			
10-00	Water Systems	C	1	0	(M) Individual components may be inoperative provided: a) Associated components are deactivated or isolated, and b) Associated components are verified not to have leaks. NOTE: Any portion of the system which operates normally may be used.
		C	1	0	(M) May be inoperative provided: a) System is drained, and b) Procedures are established to ensure that system is not serviced.
30-00	Lavatory Waste Systems	C	1	0	(M) Individual components may be inoperative provided: a) Associated components are deactivated or isolated, and b) Associated components are verified not to have leaks. NOTE: Any portion of the system which operates normally may be used.
		C	1	0	(M) Associated lavatory system(s) maybe inoperative provided: a) Associated components are deactivated or isolated to prevent leaks, and b) Associated lavatory door(s) is secured closed and placarded "INOPERATIVE" or "DO NO ENTER" NOTE: These provisions are not intended to prohibit inspections by crewmembers.



MINIMUM EQUIPMENT LIST

EMBRAER 145LR

AIRCRAFT:		REVISION NO: 09		PAGE:	
EMB-145		DATE: 26/02/2021		45-1	
SYSTEM & SEQUENCE NUMBERS		1. CAT	2. NUMBER INSTALLED		
ITEM			3. NUMBER REQUIRED FOR DISPATCH		
			4. REMARKS OR EXCEPTIONS		
45 CENTRAL MAINTENANCE COMPUTER					
45-01	Central Maintenance Computer (CMC)	C	1	0	May be inoperative provided maintenance procedures do not require its use.



MINIMUM EQUIPMENT LIST

EMBRAER 145LR

AIRCRAFT: EMB-145		REVISION NO: Re-Edición DATE: 08/12/2014	PAGE: 46-1		
SYSTEM & SEQUENCE NUMBERS	ITEM	1. CAT	2. NUMBER INSTALLED	3. NUMBER REQUIRED FOR DISPATCH	4. REMARKS OR EXCEPTIONS
		46 INFORMATION SYSTEMS			
20-01	Electronic Flight Bag Systems (EFB)				Not installed.



MINIMUM EQUIPMENT LIST

EMBRAER 145LR

AIRCRAFT: EMB-145			REVISION NO: Re-Edición DATE: 08/12/2014		PAGE: 49-1
SYSTEM & SEQUENCE NUMBERS			1. CAT	2. NUMBER INSTALLED	
ITEM				3. NUMBER REQUIRED FOR DISPATCH	
49 AIRBORNE AUXILIARY POWER				4. REMARKS OR EXCEPTIONS	
00-00	Auxiliary Power Unit (APU)	C	1	0	(M) (O) May be inoperative provided: a) APU is deactivated, and b) Procedures are not dependent upon its use.
52-02	APU Bleed Air System				Deleted, Rev 11.
70-01	APU OIL LO PRESS Caution Message	C	1	0	May be inoperative provided APU is used on ground only.
70-02	APU OIL HI TEMP Caution Message	C	1	0	May be inoperative provided APU is used on ground only.
70-03	APU FAIL Caution Message	C	1	0	May be inoperative provided APU is used on ground only.
74-01	APU Hourmeter Function	C	1	0	(M) May be inoperative provided alternate procedures are used to accomplish hourmeter function.

AIRCRAFT:		REVISION NO: Revisión 07		PAGE:	
EMB-145		DATE: 04/07/2017		52-1	
SYSTEM & SEQUENCE NUMBERS	ITEM	1. CAT	2. NUMBER INSTALLED		
			3. NUMBER REQUIRED FOR DISPATCH		
52 DOORS		4. REMARKS OR EXCEPTIONS			
12-00	Main Door Hydraulic Actuation System	B	-	-	Not installed.
51-00	C&D Aerospace Flight Deck Security Door				
	1) Door Latch	A	1	0	May be inoperative provided: <ul style="list-style-type: none"> a) Door Dead Bolt is operative, b) Door Dead Bolt is used to lock and unlock the door, and c) Repairs are made within two flight days.
	2) Flight Deck Door Panel Pressure Relief Latch	A	1	0	May be inoperative in the latched position provided repairs are made within two flight days.
	3) Dead Bolt	C	1	0	
70-00	Doors Warning System (Door Position Indication On MFD and EICAS)				
	1) Main/Service Doors	B	2	0	(O) May be inoperative provided affected door is verified closed and latched before each departure.
	2) Baggage Door	C	1	0	(O) May be inoperative provided door is verified closed and latched before each departure.
	3) Emergency Access Hatches	C	2	0	(M) May be inoperative provided affected hatch is verified closed and latched before each departure.
	4) Access Hatches	C	3	0	(M) May be inoperative provided affected hatch is verified closed and latched before each departure.
	5) Fueling Door	C	1	0	(M) May be inoperative provided door is verified closed and latched before each departure.
	6) Internal Baggage Access Door				Not applicable.



MINIMUM EQUIPMENT LIST

EMBRAER 145LR

AIRCRAFT:		REVISION NO: Re-Edición		PAGE:	
EMB-145		DATE: 08/12/2014		56-1	
SYSTEM & SEQUENCE NUMBERS	ITEM	1. CAT	2. NUMBER INSTALLED		
			3. NUMBER REQUIRED FOR DISPATCH		
56 WINDOWS			4. REMARKS OR EXCEPTIONS		
10-01	Windshield				Deleted, Rev 14. NOTE: Refer to Aircraft Maintenance Manual (AMM) or Structural Repair Manual (SRM).



MINIMUM EQUIPMENT LIST

EMBRAER 145LR

AIRCRAFT:		REVISION NO: Revisión 07		PAGE:	
EMB-145		DATE: 04/07/2017		73-1	
SYSTEM & SEQUENCE NUMBERS		1. CAT	2. NUMBER INSTALLED		
ITEM		3. NUMBER REQUIRED FOR DISPATCH			
		4. REMARKS OR EXCEPTIONS			
73 ENGINE FUEL & CONTROL					
22-01	Engine Full Authority Digital Electronic Control (FADEC) System 1) System Faults	A	4	-	May be dispatched with FADEC faults provided repairs are made in accordance with times established by the engine manufacturer (refer to Rolls-Royce Maintenance Manual CSP340022). No Extensions are authorized.
22-02	Automatic Takeoff Thrust Control System (ATTCS)(Airplanes equipped with A,A1/1, A1, and A3 engines only)	C	1	0	(O) May be inoperative provided T/O-1 thrust mode can be selected and used through the Takeoff Data Setting.
32-01	Engine Fuel Temperature Sensors	C	2	0	(O) May be inoperative provided temperature of fuel in the tank remains above 4 degrees C throughout the flight.
		C	2	0	(O) May be inoperative with fuel tank temperature below 4 degrees C provided icing inhibitor is added to the fuel.



MINIMUM EQUIPMENT LIST

EMBRAER 145LR

AIRCRAFT:		REVISION NO: Re-Edición		PAGE:	
EMB-145		DATE: 08/12/2014		73-2	
SYSTEM & SEQUENCE NUMBERS		1. CAT	2. NUMBER INSTALLED		
ITEM		3. NUMBER REQUIRED FOR DISPATCH			
		4. REMARKS OR EXCEPTIONS			
73 ENGINE FUEL & CONTROL					
33-01	E1 (2) FUEL IMP BYP Advisory Messages	C	2	1	(M) One may be inoperative provided: <ul style="list-style-type: none"> a) Associated engine fuel temperature sensor is operative, b) Malfunction is verified to be in the fuel filter electrical/mechanical impending-bypass indicator or its associated wiring, c) Fuel filter electrical/mechanical impending-bypass indicator is checked not extended at least every 10 flight hours, and d) Fuel filter mechanical actual-bypass indicator is checked not extended at least every 10flight hours.
33-02	Fuel Filters	A	2	1	(M) One E1 (2) FUEL IMP BYP advisory message may be displayed per engine provided: <ul style="list-style-type: none"> a) Associated fuel-filter mechanical actual-bypass indicator is checked not extended before each departure, and b) Fuel filter is replaced within10 flight hours.
40-03	Fuel Flow Indications	C	2	1	(O) One may be inoperative provided: <ul style="list-style-type: none"> a) Associated engine parameters are monitored throughout the flight, and b) Both fuel quantity indications operate normally.



MINIMUM EQUIPMENT LIST

EMBRAER 145LR

AIRCRAFT:		REVISION NO: Re-Edición		PAGE:	
EMB-145		DATE: 08/12/2014		74-1	
SYSTEM & SEQUENCE NUMBERS		1. CAT	2. NUMBER INSTALLED		
ITEM		3. NUMBER REQUIRED FOR DISPATCH			
74 IGNITION		4. REMARKS OR EXCEPTIONS			
20-00	Ignition System Channels	B	4	3	(O) One may be inoperative provided engine is started by positioning the ignition selector knob to ON.



MINIMUM EQUIPMENT LIST

EMBRAER 145LR

AIRCRAFT:		REVISION NO: Re-Edición		PAGE:	
EMB-145		DATE: 08/12/2014		76-1	
SYSTEM & SEQUENCE NUMBERS		1. CAT	2. NUMBER INSTALLED		
ITEM			3. NUMBER REQUIRED FOR DISPATCH		
			4. REMARKS OR EXCEPTIONS		
76 ENGINE CONTROLS					
12-00	Engine takeoff Data Setting Knob	B	1	0	(O) May be inoperative provided flight crewmember check MFD takeoff data before takeoff.



MINIMUM EQUIPMENT LIST

EMBRAER 145LR

AIRCRAFT: EMB-145		REVISION NO: Re-Edición DATE: 08/12/2014		PAGE: 77-1	
SYSTEM & SEQUENCE NUMBERS		1. CAT	2. NUMBER INSTALLED		
ITEM		3. NUMBER REQUIRED FOR DISPATCH			
77 ENGINE INDICATING		4. REMARKS OR EXCEPTIONS			
41-02	HP Vibration Indication	C	2	1	One may be inoperative provided tactile or audible indications allow the vibrating engine to be identified.

AIRCRAFT:		REVISION NO: Re-Edición		PAGE:	
EMB-145		DATE: 08/12/2014		78-1	
SYSTEM & SEQUENCE NUMBERS	ITEM	1. CAT	2. NUMBER INSTALLED		
			3. NUMBER REQUIRED FOR DISPATCH		
78 ENGINE EXHAUST			4. REMARKS OR EXCEPTIONS		
30-00	Thrust Reversers	C	2	1	(M) (O) Any door actuation, lock or control on one thrust reverser maybe inoperative provided: a) Thrust Reverser is not used, and b) System is deactivated and secured stowed. NOTE: Reverse thrust operation with one thrust reverser secured closed will be accomplished only if the operative thrust lever is set to the reverse range and the thrust lever of the affected side is set to idle.
34-00	ENG 1 (2) REV DISAGREE Messages	C	2	1	(M) (O) May be inoperative on one thrust reverser provided: a) Thrust reverser is not used, and b) System is deactivated and secured stowed. NOTE: Reverse thrust operation with one thrust reverser secured closed will be accomplished only if the operative thrust lever is set to the reverse range and the thrust lever of the affected side is set to idle.
34-05	Idle Stop (Solenoid)	C	2	1	(M) (O) May be inoperative provided: a) Thrust reverser is considered inoperative, and b) System is deactivated and secured stowed.

AIRCRAFT:		REVISION NO: Re-Edición		PAGE:	
EMB-145		DATE: 08/12/2014		79-1	
SYSTEM & SEQUENCE NUMBERS	ITEM	1. CAT	2. NUMBER INSTALLED		
			3. NUMBER REQUIRED FOR DISPATCH		
79 ENGINE OIL		4. REMARKS OR EXCEPTIONS			
32-01	Low Oil Pressure Switches	C	2	0	(M) May be inoperative provided: <ul style="list-style-type: none"> a) Oil pressure indication is available and is monitored throughout the flight, and b) Engine oil quantity is serviced each flight day.
33-01	Oil Level Indication Systems	C	2	0	(M) May be inoperative provided engine oil quantity is serviced each flight day.
34-01	Oil Particle Sensors	C	2	0	(M) May be inoperative provided the oil tank mag plug is visually checked each flight day.
35-01	E1 (2) OIL IMP BYP Messages	C	2	0	(M) May be inoperative provided: <ul style="list-style-type: none"> a) Visual indicator(s) are checked each flight day and neither is found extended, and b) The CMC is checked each flight day and the ENG OIL DEBRIS maintenance message is not present. NOTE: The affected E1 (2) OIL IMP BYP advisory message may be displayed.
35-02	Oil Filters	A	2	1	(M) One E1 (2) OIL IMP BYP advisory message may be displayed for one engine provided: <ul style="list-style-type: none"> a) Maintenance procedures do not require its replacement, and b) Oil filter element is replaced in less than 20 flight hours.



MINIMUM EQUIPMENT LIST

EMBRAER 145LR

AIRCRAFT: EMB-145			REVISION NO: Re-Edición DATE: 08/12/2014		PAGE: 80-1
SYSTEM & SEQUENCE NUMBERS			1. CAT	2. NUMBER INSTALLED	
ITEM				3. NUMBER REQUIRED FOR DISPATCH	
80 STARTING				4. REMARKS OR EXCEPTIONS	
00-00	Engine Start/Stop Switch Protection Guards	C	2	0	
10-02	Starter Control Valves	B	2	1	(M) (O) One may be inoperative closed provided: a) Associated EICAS Caution message E1(2) ATS SOV OPN operates normally, and b) Manual override start procedures are used.



MINIMUM EQUIPMENT LIST

EMBRAER 145LR

GUIDELINES (M) & (O) PROCEDURES

LINK CONEXIÓN AÉREA, S.A. DE C.V. has identified a need for certain procedures to provide an adequate level of safety while providing relief for the following items. These procedures must be established by the operator. A letter (M) indicates Maintenance Procedure is required and a letter (O) indicates that an Operational procedure is required.

The following guidelines are to help establish these required procedures:

ATA CHAPTER 21 AIR CONDITIONING**21-22-04 EXTERNAL GROUND CONNECTOR CHECK VALVE**

Placard Air Conditioning/Pneumatic Panel "GROUND CONNECTION

CHECK VALVE OPEN".

OPERATIONAL PROCEDURES

Refer to item 21-31-03 for unpressurized configuration.

MAINTENANCE PROCEDURES

Refer to item 21-31-03 for outflow valves secured open, if required.

21-22-06 BAGGAGE COMPARTMENT VENTILATION SYSTEM

Placard Fire Detection/Extinguishing Panel "VENTILATION SYSTEM INOP".

OPERATIONAL PROCEDURES

None.

MAINTENANCE PROCEDURES

Alternate method (below) may be flight crewmember accomplished.

Deactivate Baggage Recirculation Fan as follows:

- On the circuit breaker panel, open the MISCELLANEOUS/ BAGGAGE RECIRC FAN circuit breaker and attach a do-not-close tag on it.
- Open access 272DR, Rear Electronic Compartment Access Hatch. Gain access to the rear electronic compartment and locate the baggage recirculation fan (See Figure on AMM PART I 21-27-00).
- Disconnect and stow electrical connector of the fan.
- Close BAGGAGE RECIRC FAN circuit breaker.

An alternate method to deactivate baggage compartment fan is pulling and collaring BAGGAGE RECIRC FAN circuit breaker. The Baggage Fire Extinguishing Button will not illuminate during system test, however EICAS message BAGG SMOKE and extinguishing system will remain operate normally.



MINIMUM EQUIPMENT LIST

EMBRAER 145LR

21-23-03 GASPER FAN

Placard Gasper Fan Button "INOP".

OPERATIONAL PROCEDURES

None.

MAINTENANCE PROCEDURES

May be flight crewmember accomplished. Pull and safety gasper fan circuit breaker (F25).

21-24-01 RECIRCULATION FANS

Placard Recirculation Button "INOP".

OPERATIONAL PROCEDURES

None.

MAINTENANCE PROCEDURES

Recirculation Fan deactivated:

May be flight crewmember accomplished. Pull and safety the affected recirculation fan circuit breaker, COCKPIT RECIRC (J14) and/or CABIN RECIRC (J21).

21-24-02 RECIRCULATION FAN VALVES

Placard Air Conditioning/Pneumatic Control Panel "RECIRCULATION FAN VALVE OPEN".

OPERATIONAL PROCEDURES

None.

MAINTENANCE PROCEDURES

- Perform SUBTASK 21-20-00-710-001-A00 (AMM) for recirculation fan operational check.
- Refer to Item 21-24-01 for recirculation fan deactivation.



MINIMUM EQUIPMENT LIST

EMBRAER 145LR

21-24-03 AIR DISTRIBUTION VALVES

Placard Air Conditioning/Pneumatic Control Panel "AIR DISTRIBUTION VALVE STUCK CLOSED".

OPERATIONAL PROCEDURES

None.

MAINTENANCE PROCEDURES

May be flight crewmember accomplished.

Perform TASK 21-22-01-040-801-A (AMM) for air distribution valve deactivation.



MINIMUM EQUIPMENT LIST

EMBRAER 145LR

21-25-01 RAM AIR VALVES

Placard affected Air Conditioning Pack Button "INOP".

OPERATIONAL PROCEDURES

Failure of One Ram Air Valve:

Conduct flight at or below 25000 ft. Associated Air Conditioning Pack must be OFF.

Failure of Both Ram Air Valves:

Conduct flight at or below 10000 ft. Both Air Conditioning Packs must be OFF. Refer to Item 21-31-03 for unpressurized configuration.

MAINTENANCE PROCEDURES

Perform Task 21-25-01-040-801-A (AMM) for ram air valve deactivation.

21-25-02 RAM AIR CHECK VALVES

Placard Air Conditioning/Pneumatic Control Panel "RAM AIR INOP OPEN".

OPERATIONAL PROCEDURES

Refer to Item 21-31-03 for unpressurized configuration.

MAINTENANCE PROCEDURES

Refer to Item 21-31-03 for outflow valves secured open, if required.

21-26-00 FORWARD ELECTRONIC COMPARTMENT VENTILATION SYSTEM

Placard Air Conditioning/Pneumatic Control Panel "FWD ELEC COMPT VENT INOP".

OPERATIONAL PROCEDURES

None.

MAINTENANCE PROCEDURES

None.



MINIMUM EQUIPMENT LIST

EMBRAER 145LR

21-30-00 PRESSURIZATION CONTROL SYSTEM

Placard Pressurization Mode Selector Button "MAN INOP", or "AUTO INOP", or "AUTO/MAN INOP".

OPERATIONAL PROCEDURES

Operation in Manual Mode:

To verify that the manual mode is operative:

Pressurization Manual ControllerFULL UP

Pressurization Mode Selector Button.....MANUAL

Check that MAN inscription illuminates inside the button.

If automatic control of the pressurization system is not possible, manual control of cabin pressure can be maintained via the pneumatic outflow valve using the following procedures:

- Rotate the Manual Pressurization knob clockwise to FULL UP position.
- Select MAN with the guarded pressurization mode selector button.
- Rotate the knob clockwise to increase cabin altitude, rotate it counter-clockwise to decrease cabin altitude.
- Monitor cabin differential pressure to ensure it remains within limits.

Operation in Automatic Mode:

If manual control of the pressurization system is not possible, automatic control of cabin pressure can be maintained via the electropneumatic outflow valve monitoring cabin differential pressure to ensure it remains within limits.

Unpressurized Configuration:

Refer to either the Operational or Maintenance procedure under Item 21-31-03 for electropneumatic/pneumatic outflow valves secured open.

MAINTENANCE PROCEDURES

Refer to Item 21-31-03 for electropneumatic/pneumatic outflow valves secured closed or secured open.

NOTE: For outflow valves secured open procedure on item 21-31-03, the airplane may be dispatched after either the operational procedure or the maintenance procedure is accomplished (only one of both is required to be performed).



MINIMUM EQUIPMENT LIST

EMBRAER 145LR

21-31-03 OUTFLOW VALVES

Placard Pressurization Mode Selector Button "MAN INOP" if pneumatic outflow valve is inoperative, or "AUTO INOP" if electropneumatic outflow valve is inoperative, or "AUTO/MAN INOP" if both outflow valves are inoperative.

NOTE: In case of pressurization static port heating inoperative, the airplane may be dispatched by this item.

OPERATIONAL PROCEDURES

Unpressurized Configuration:

-Outflow Valves..... OPEN

-Outflow valves may be kept open through one of the following ways:

-Pressurization Dump Button..... PRESSED

OR

-Pressurization Mode Selector Button PRESSED

-Manual Controller Knob..... UP

OR

-Using the Opening Tool Kit (refer to maintenance procedures).

OR

-Removing the valves.

NOTE: For flight in unpressurized configuration, the airplane may be dispatched after either the operational procedure or the maintenance procedure to secure both outflow valves open is accomplished (only one of both is required to be performed).

Bleed Air Buttons AS REQUIRED

If air conditioning packs are going to be used, maintain the Bleed Air Buttons at pressed position (bleed open), otherwise, set them to released position (bleed closed).

Pack Buttons..... AS REQUIRED

If air conditioning packs are going to be used, maintain the Pack Buttons at pressed position (pack valve open), otherwise, set them to released position (pack valve closed).

Recirculation Fans..... AS REQUIRED

Altitude..... 10000 FT



MINIMUM EQUIPMENT LIST

EMBRAER 145LR

MAINTENANCE PROCEDURES

Electropneumatic Outflow Valve Secured Closed:

- Gain access to the electropneumatic outflow valve located in the rear pressure bulkhead.
- Perform AMM TASK 21-31-03-000-801-A to remove the electropneumatic outflow valve.
- Safety the valve in the closed position, as shown in outflow valves figure.
- Open fitting 1 (see outflow valves figure) and plug tube and valve with plugs P/N AN 806-D5 and P/N AN 929-5.
- Perform AMM TASK 21-31-03-400-801-A to install the electropneumatic outflow valve.
- Install removed access panel.

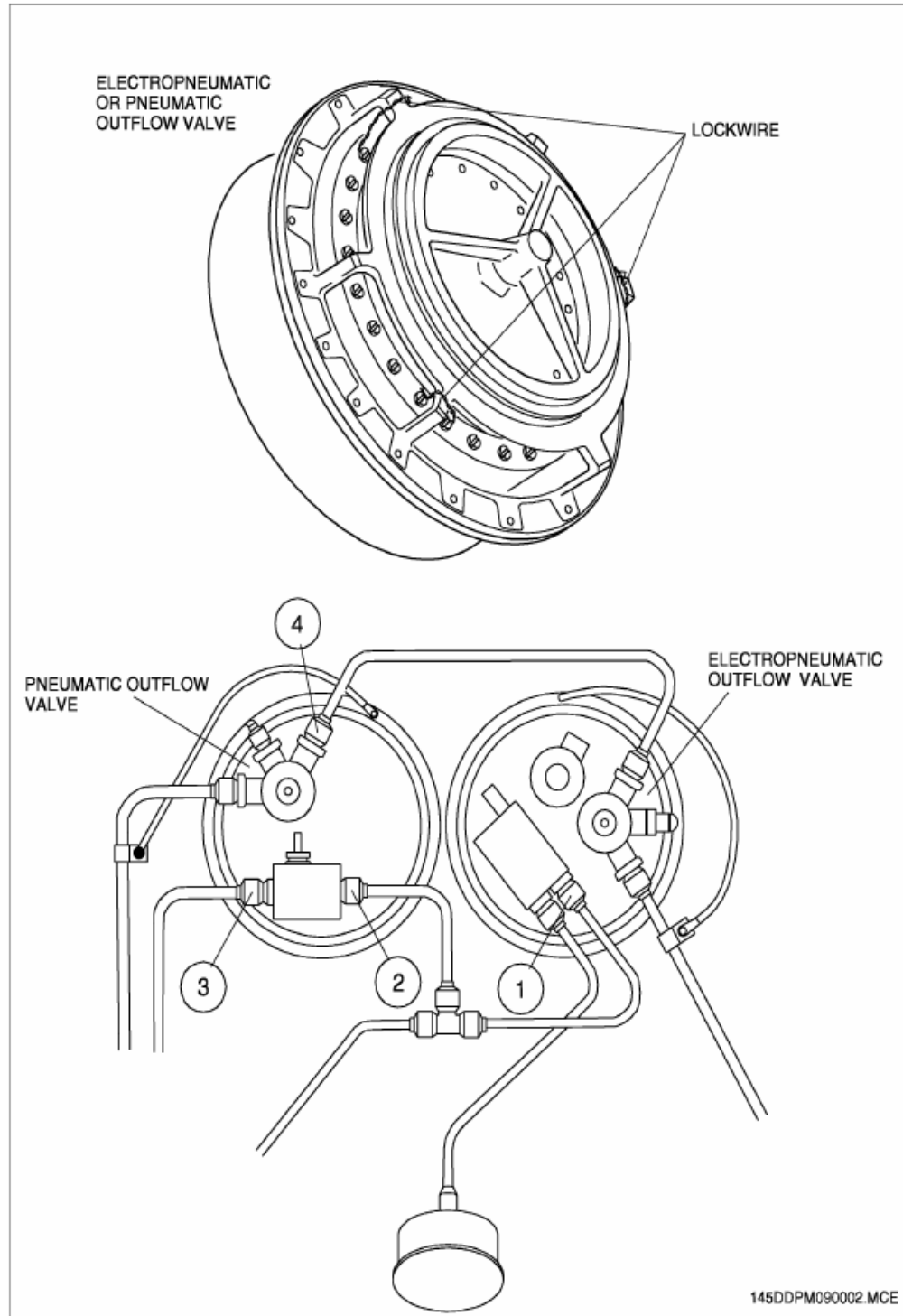

OUTFLOW VALVES



MINIMUM EQUIPMENT LIST

EMBRAER 145LR

Both Outflow Valves Secured Open (if applicable):

- Gain access to the both outflow valves located in the rear pressure bulkhead.
- Using both hands, open one of the valves by pressing the poppet and insert the opening tool (GSE 282) so as to fit it in the valve axle guide (see Outflow Valve Secured Open figure).
- Assure the opening tool is fitted on the axle in order to avoid valve closing.
- Repeat the procedure for the remaining outflow valve.

NOTE: To remove the Opening Tool from the valve assembly, just pull it out.

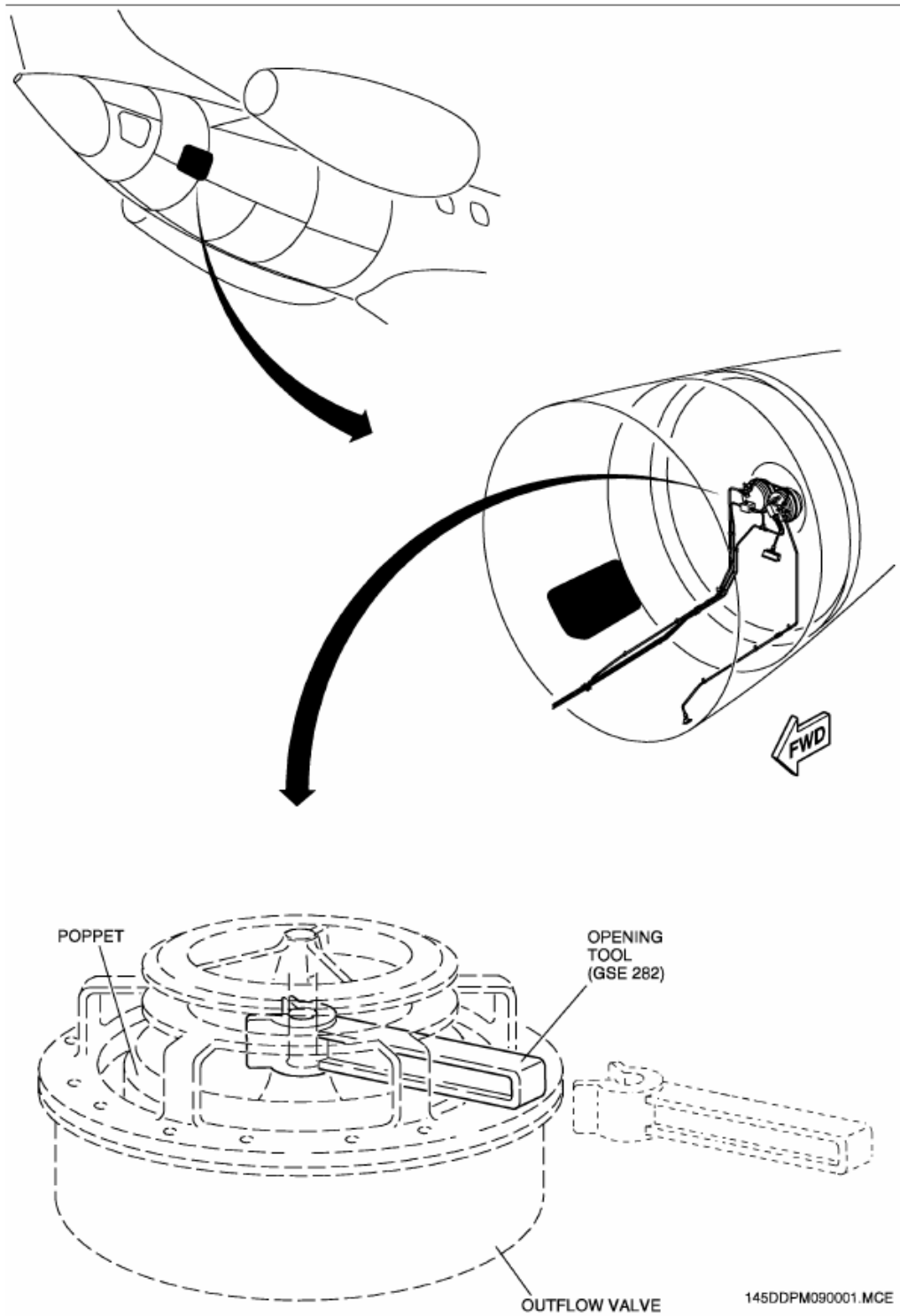

OUTFLOW VALVE SECURED OPEN

21-32-01 CABIN PRESSURE ACQUISITION MODULE

Placard Digital Controller "CABIN ALT WARN INOP", or "CABIN DIFF PRESS IND INOP", or "CABIN ALT IND INOP", or "CABIN RATE OF CHANGE IND INOP".

OPERATIONAL PROCEDURES

Refer to Item 21-31-03 for unpressurized configuration.

Use to convert cabin differential pressure into cabin altitude:

AIRPLANE ALTITUDE (ft)	CABIN ALTITUDE (ft)	DIFFERENTIAL PRESSURE (psi)
10000	300	4.4
11000	500	4.7
12000	700	5
13000	900	5.2
14000	1100	5.5
15000	1300	5.7
16000	1500	5.9
17000	1700	6.1
18000	1900	6.3
19000	2200	6.5
20000	2400	6.7
21000	2700	6.8
22000	2900	7
23000	3200	7.1
24000	3400	7.2
25000	3800	7.3
26000	4100	7.4
27000	4400	7.5
28000	4700	7.6
29000	5000	7.6
30000	5400	7.7
31000	5700	7.7
32000	6100	7.7
33000	6500	7.7
34000	6800	7.8
35000	7200	7.8
36000	7600	7.8
37000	8000	7.8

MAINTENANCE PROCEDURES

Refer to Item 21-31-03 for outflow valves secured open, if required.

21-32-02 CABIN PRESSURE CONTROL SYSTEM HIGH ALTITUDE MODE

Placard "CABIN PRESS CTRL SYS HI ALT MODE INOP".

OPERATIONAL PROCEDURES

None.

MAINTENANCE PROCEDURES

None.

21-51-00 AIR CONDITIONING PACK SYSTEMS

Placard affected Air Conditioning Pack Button "INOP".

OPERATIONAL PROCEDURES

NOTE: -The EICAS caution message PACK 1 (2) OVLD may be displayed.

-Pack 1 will not close in case of single pack below 24000 ft in icing conditions.

Unpressurized Configuration (airplanes with conventional electromechanical standby instruments):

Refer to Item 21-31-03 for unpressurized configuration. In this condition, ambient temperature, on the ground, must be below ISA + 21°C.

NOTE: The EICAS advisory message BLD 1 (2) VLV CLSD may be displayed.

Operational Check of Pack and Recirculation Fan (airplanes with ISIS):

The recirculation fan operates only when the RECIRC switch is ON and the related pack valve is open. Set the RECIRC switch to ON and check that the airflow through the cockpit general outlets increases.

NOTE: The EICAS advisory message BLD 1(2) VLV CLSD may be displayed.

MAINTENANCE PROCEDURES**Ram Air Valves Operational Check (airplanes with conventional electromechanical standby instruments):**

Perform TASK 21-25-01-700-801-A (AMM) for ram air valves operational check.



MINIMUM EQUIPMENT LIST

EMBRAER 145LR

21-60-04 COCKPIT AUTOMATIC AND MANUAL TEMPERATURE CONTROL SYSTEMS

Placard associated Temperature Control Mode Knob "AUTO INOP" or Placard affected Air Conditioning Pack Button "INOP".

OPERATIONAL PROCEDURES

Associated Temperature Control Mode Selector.....MAN

Monitor cabin or cockpit temperature and control it by using the associated Temperature Adjusting Knob.

NOTE: The EICAS caution message PACK 1 (2) OVLD may be displayed.

Operational Check of Pack and Recirculation Fan (airplanes with ISIS):

The recirculation fan operates only when the RECIRC switch is ON and the related pack valve is open. Set the RECIRC switch to ON and check that the airflow through the cockpit general outlets increase.

NOTE: The EICAS advisory message BLD 1(2) VLV CLSD may be displayed.

MAINTENANCE PROCEDURES

None.

21-60-05 CABIN AUTOMATIC AND MANUAL TEMPERATURE CONTROL SYSTEMS

Placard associated Temperature Control Mode Knob "MAN INOP" or Placard affected Air Conditioning Pack Button "INOP".

OPERATIONAL PROCEDURES

NOTE: The EICAS caution message PACK 1 (2) OVLD may be displayed.

Operational Check of Pack and Recirculation Fan (airplanes with ISIS):

The recirculation fan operates only when the RECIRC switch is ON and the related pack valve is open. Set the RECIRC switch to ON and check that the airflow through the cockpit general outlets increase.

NOTE: The EICAS advisory message BLD 1(2) VLV CLSD may be displayed.

MAINTENANCE PROCEDURES

None.



MINIMUM EQUIPMENT LIST

EMBRAER 145LR

21-60-06 ATTENDANT'S TEMPERATURE CONTROL

Placard Attendant's Temperature Control "INOPERATIVE".

OPERATIONAL PROCEDURES

None.

MAINTENANCE PROCEDURES

None.

21-61-02 COCKPIT AND CABIN TEMPERATURE INDICATION SYSTEMS

Placard Air Conditioning and Pneumatic Control Panel "CABIN TEMP IND INOP" or "CKPT TEMP IND INOP".

OPERATIONAL PROCEDURES

None.

MAINTENANCE PROCEDURES

None.

ATA CHAPTER 22 AUTOPILOT

22-10-00 AUTOPILOT/FLIGHT DIRECTOR FUNCTIONS

Placard Flight Guidance Controller "AP/FD/YD INOP".

OPERATIONAL PROCEDURES

None.

MAINTENANCE PROCEDURES

None.

22-11-01 FLIGHT GUIDANCE CONTROLLER PANEL

Placard affected Flight Guidance Controller Panel button or knob "INOP".

OPERATIONAL PROCEDURES

Flight Director Buttons Inoperative:

In case of no FD indication on PFD, select any button from flight guidance panel (except FD buttons) and it will be indicated on PFD.

Yaw Damper Engage Button Inoperative:

Verify AP and YD indication on PFD with autopilot engaged.

Operational Altitude Preselect Knob Check:

On ground, with airplane energized, turn the Altitude Preselect Knob (ASEL) selecting altitudes above and below the field elevation, verify that the selected altitude matches the desired altitude and if is displayed on the top right corner of the PFD.

Altitude Preselect Knob (ASEL) Inoperative:

Refer to item 34-31-02 Operational Procedure.

MAINTENANCE PROCEDURES

None.



MINIMUM EQUIPMENT LIST

EMBRAER 145LR

22-11-08 TOUCH CONTROL STEERING BUTTON (TCS SYNC BUTTONS)

Placard Flight Guidance Controller Panel "LEFT OR RIGHT OR BOTH TCS BUTTON INOP".

OPERATIONAL PROCEDURES

None.

MAINTENANCE PROCEDURES

None.

22-11-09 GO-AROUND BUTTONS

Placard Flight Guidance Controller Panel "LEFT or RIGHT or BOTH GA BUTTON INOP".

OPERATIONAL PROCEDURES

CAT I Operation:

None.

MAINTENANCE PROCEDURES

None.



MINIMUM EQUIPMENT LIST

EMBRAER 145LR

ATA CHAPTER 23 COMMUNICATIONS

23-00-00 COMMUNICATIONS SYSTEM (VHF, HF, UHF)

Placard associated Control Panel "VHF INOP".

MAINTENANCE PROCEDURES

None.

23-15-00 SATELLITE COMMUNICATION SYSTEM (SATCOM)

Placard SATCOM handset "INOP".

OPERATIONAL PROCEDURES

According to MEL remarks.

MAINTENANCE PROCEDURES

None.

23-30-01 PASSENGER ADDRESS SYSTEM

Placard Digital Audio Panels "PAX ADRS INOP".

OPERATIONAL PROCEDURES

[Refer to MS \(Manual de Sobrecargos\) Chapter 2, 2.4.2, page 2](#) [Página 25](#) to follow the right operational procedure.

MAINTENANCE PROCEDURES

None.



MINIMUM EQUIPMENT LIST

EMBRAER 145LR

23-31-01 CREWMEMBER INTERPHONE SYSTEM(S)

Placard ICU Panel "CREWMEMBER INTERPHONE INOP".

OPERATIONAL PROCEDURES

Refer to MS (Manual de Sobrecargos) Chapter 2, 2.4.2, page 2 Página 26 to accomplish the alternate operational procedure.

MAINTENANCE PROCEDURES

None.

23-31-02 ALERTING SYSTEMS (AUDIO/VISUAL)

Placard CABIN or CAB EMER Buttons on ICU Panel "LIGHT INOP".

Placard CABIN Button on ICU Panel, PILOT light in the attendant's handset or secondary attendant call panel "LIGHT INOP".

Placard CABIN Button and ICU Panel or PILOT light in the attendant's handset "CHIME INOP".

OPERATIONAL PROCEDURES

Refer to MS (Manual de Sobrecargos) Chapter 2, 2.4.2, page 2 Página 26 to accomplish the alternate operational procedure.

MAINTENANCE PROCEDURES

None.

23-31-03 HANDSET SYSTEMS

Placard Attendant's Handset "INOP".

OPERATIONAL PROCEDURES

Refer to MS (Manual de Sobrecargos) Chapter 2, 2.4.2, page 2 Página 26 to accomplish the alternate operational procedure.

MAINTENANCE PROCEDURES

None.



MINIMUM EQUIPMENT LIST

EMBRAER 145LR

23-32-02 PRE – RECORDED PASSENGER ANNOUNCEMENT SYSTEM

Placard Entertainment System Panel "INOP".

OPERATIONAL PROCEDURES

Refer to MS (Manual de Sobrecargos) Chapter 9, page 9 Página 6, to know the operational procedure.

MAINTENANCE PROCEDURES

None.

23-33-01 PASSENGER CABIN SPEAKERS

Placard Digital Audio Panels "PAX SPEAKERS INOP".

Refer to MS (Manual de Sobrecargos) Chapter 2, 2.4.2, page 2 Página 25 and page 2 Página 26 to follow the right operational procedure.

OPERATIONAL PROCEDURES

None.

MAINTENANCE PROCEDURES

None.

23-51-03 PUSH TO TALK (PTT) (BUTTON ON GLARESHIELD PANEL CONTROL WHEEL)

Placard affected PTT Button "INOP".

OPERATIONAL PROCEDURES

None.

MAINTENANCE PROCEDURES

None.



MINIMUM EQUIPMENT LIST

EMBRAER 145LR

23-51-04 FLIGHT DECK SPEAKERS

Placard Digital Audio Panels "FLT DECK SPEAKERS INOP".

OPERATIONAL PROCEDURES

None.

MAINTENANCE PROCEDURES

None.

23-51-05 FLIGHT DECK HEADSETS

Placard affected headset "INOP".

OPERATIONAL PROCEDURES

None.

MAINTENANCE PROCEDURES

None.

23-51-07 FLIGHT DECK HANDHELD MICROPHONES

Placard Pilot's Jack Panels "HAND MIC INOP".

OPERATIONAL PROCEDURES

None.

MAINTENANCE PROCEDURES

None.

23-71-00 COCKPIT VOICE RECORDER SYSTEM

Placard Voice Recorder Panel "INOP".

OPERATIONAL PROCEDURES

None.

MAINTENANCE PROCEDURES

None.



MINIMUM EQUIPMENT LIST

EMBRAER 145LR

23-80-00 RADIO MANAGEMENT UNITS (RMU'S)

Placard associated RMU Bezel "NAV/COM TUN INOP" or "MEM FUNC INOP".

OPERATIONAL PROCEDURES

None.

MAINTENANCE PROCEDURES

None.

23-81-02 TUNING BACKUP CONTROL HEAD

Placard Tuning Backup Control Head Panel "INOP".

OPERATIONAL PROCEDURES

None.

MAINTENANCE PROCEDURES

None.



MINIMUM EQUIPMENT LIST

EMBRAER 145LR

ATA CHAPTER 24 ELECTRICAL POWER

24-20-01 GENERATOR CURRENT INDICATIONS

Placard affected Generator Button "CURRENT IND INOP".

OPERATIONAL PROCEDURES

According to the MEL remarks.

MAINTENANCE PROCEDURES

None.

24-20-02 GENERATOR VOLTAGE INDICATIONS

Placard affected Generator Button "VOLT IND INOP".

OPERATIONAL PROCEDURES

None.

MAINTENANCE PROCEDURES

None.

24-20-03 INVERTER

Placard AC PWR Button "INOP" and placard PFD Bezel "GPWS/TCAS INOP".

NOTE: - TCAS may be electric fed by either inverter or DC Bus. Only TCAS powered by the inverter is considered inoperative.

- GPWS/Windshear may be fed by DC bus or AC bus. Only GPWS/Windshear powered by AC bus is considered inoperative.

OPERATIONAL PROCEDURES

None.

MAINTENANCE PROCEDURES

None.



MINIMUM EQUIPMENT LIST

EMBRAER 145LR

24-31-01 ENGINE DRIVEN GENERATORS

Placard affected Generator Button "INOP".

OPERATIONAL PROCEDURES

According to the MEL remarks.

MAINTENANCE PROCEDURES

May be flight crewmember accomplished.

Pull and secure affected generator GEN 1 (2, 3 or 4) POR and GEN 1 (2, 3 or 4) OUTVOLT circuit breakers.

GENERATOR	CIRCUIT BRAKERS
1	E8 and E9 Left DC Distribution Box
2	E8 and E9 Right DC Distributio Box
3	D8 and D9 Left DC Distribution Box
4	D8 and D9 Right DC Distribution Box

The following maintenance procedures should be accomplished only if flight crew reports a continuous contactor switching noise with an unusual generating indication and no associated EICAS message. In this case, the faulty generator is absorbing all the load while operating in parallel with other in good condition. In this condition, the voltage and current indication on MFD Electrical page of the faulty generator indicates that it is carrying all loads, while the voltage and current indication on MFD Electrical page of the good generator indicates zero load. In this failure mode, the unloaded generator remains connected to the DC Bus. Its line contactor cycles and there is no GEN OFF BUS message. In order to identify the faulty generator, proceed as follows:

- BUS TIES Switch..... OFF
- All GEN Button..... ON
- Voltage and Current (All Generators - on MFD)CHECK

If there is any generator carrying all the load:

- Affected GEN Button OFF
- BUS TIES Switch..... ON
- Voltage and Current

(Remaining 3 Generators - on MFD)CHECK

If the 3 remaining generators are operating normally, disconnect the affected generator of the respective DC Bus by releasing its button on the Electric System Panel.



MINIMUM EQUIPMENT LIST

EMBRAER 145LR

24-31-02 ENGINE DRIVEN GENERATORS BEARINGS (ONLY FOR 30086-11 GENERATOR MODEL)

OPERATIONAL PROCEDURES

None.

MAINTENANCE PROCEDURES

None.

24-34-01 APU STARTER GENERATOR

In case of Generator Function failure, placard APU Starter Generator Button "INOP".

OPERATIONAL PROCEDURES

None.

MAINTENANCE PROCEDURES

None.

24-37-00 DC/DC POWER CONVERSION SYSTEM

Placard "DO NOT USE IN FLIGHT".

OPERATIONAL PROCEDURES

None.

MAINTENANCE PROCEDURES

None.

24-40-00 EXTERNAL POWER SYSTEM

Placard GPU Button "GPU SYS INOP" or "GPU AVAIL LIGHT INOP".

OPERATIONAL PROCEDURES

None.

MAINTENANCE PROCEDURES

None.



MINIMUM EQUIPMENT LIST

EMBRAER 145LR

ATA CHAPTER 25 EQUIPMENT AND FURNISHINGS

25-11-00 EYE LOCATOR

Placard on Windshield Central Frame Top "EYE LOCATOR REMOVED".

OPERATIONAL PROCEDURES

None.

MAINTENANCE PROCEDURES

None.

25-11-01 FLIGHT CREW SEATS

Placard the affected Seat Control "INOP".

OPERATIONAL PROCEDURES

In case of vertical power seat adjustment failure, use the manual system to adjust the seat.

MAINTENANCE PROCEDURES

May be flight crewmember accomplished. In case of vertical power seat adjustment, pull and safety the associated SEAT ADJUST circuit breaker (E5 or E28).

NOTE: Some airplanes may present a different circuit breaker positioning configuration. Specific configuration may be found in the Aircraft Maintenance Manual (AMM).



MINIMUM EQUIPMENT LIST

EMBRAER 145LR

25-11-02 PRIMARY OBSERVER SEAT (INCLUDING ASSOCIATED EQUIPMENT)

Placard Observer's Seat "OBSERVER'S SEAT INOP - DO NOT OCCUPY". If required, placard one Passenger Seat "RESERVED". If only the Audio Panel is inoperative, placard it "INOP".

NOTE: If the Oxygen System Pressure is insufficient for three cockpit occupants, the observer seat must be considered inoperative.

OPERATIONAL PROCEDURES

None.

MAINTENANCE PROCEDURES

None.

25-11-04 FLIGHT ATTENDANT SEAT ASSEMBLY

Placard Attendant's Seat "INOP - DO NOT OCCUPY". Placard assigned Passenger Seat "FOR FLIGHT ATTENDANT ONLY".

OPERATIONAL PROCEDURES

Flight Attendant will occupy the passenger seat closest to her duty station. Upon completion of before takeoff cabin announcements and cabin inspection, Flight Attendant will notify the captain that it is ready for departure. Captain will allow the Flight Attendant to be seated before takeoff roll. All other Flight Attendant procedures remain the same.

MAINTENANCE PROCEDURES

May be flight crewmember accomplished. The seat may be secured in the stowed position by using seat belt/shoulder harness or secured with baggage tape or equivalent.

25-12-01 SUNVISORS

If not missed, placard the affected sunvisor "INOP".

OPERATIONAL PROCEDURES

None.

MAINTENANCE PROCEDURES

None.



MINIMUM EQUIPMENT LIST

EMBRAER 145LR

25-12-02 COCKPIT CONVENIENCE ITEM(S)

OPERATIONAL PROCEDURES

None.

MAINTENANCE PROCEDURES

None.

25-12-03 LIGHTED/MECHANICAL CHECKLIST

Placard the affected Mechanical Checklist Panel "INOP".

OPERATIONAL PROCEDURES

None.

MAINTENANCE PROCEDURES

None.

25-12-04 CHART HOLDERS

If not missing, placard the affected Chart Holder "INOP".

OPERATIONAL PROCEDURES

None.

MAINTENANCE PROCEDURES

None.



MINIMUM EQUIPMENT LIST

EMBRAER 145LR

25-21-05 PASSENGER SEAT(S)

Placard the associated Seat "DO NOT OCCUPY" or "DO NOT STOW BAGGAGE UNDER THIS SEAT".

OPERATIONAL PROCEDURES

As required to meet MEL remarks.

MAINTENANCE PROCEDURES

May be flight crewmember accomplished. As required to meet MEL remarks.

25-22-00 OVERHEAD STORAGE BIN(S) / CABIN AND GALLEY STORAGE COMPARTMENT/CLOSETS

Placard Overhead Bin "INOPERATIVE DO NOT USE".

OPERATIONAL PROCEDURES

Notify Flight Attendant that no items are to be stowed in the affected compartment.

MAINTENANCE PROCEDURES

Overhead Bin Removal:

Perform TASK 25-22-03-000-801-A (AMM) for overhead bin removal.

Overhead Bin secured closed or open:

May be flight crewmember accomplished. As required to secure open or closed. The door may be secured closed using suitable selfadhesive tape applied vertically over the bin latch with an overlap of at least 4" above and below from the latch.

25-27-02 LAVATORY BULKHEAD PEEPHOLE

OPERATIONAL PROCEDURES

None.

MAINTENANCE PROCEDURES

Perform TASK 25-27-02-300-801-A (AMM) to repair the forward baggage compartment partition.



MINIMUM EQUIPMENT LIST

EMBRAER 145LR

25-27-09 FORWARD ATTENDANT CONTROL PANEL COVER

OPERATIONAL PROCEDURES

None.

MAINTENANCE PROCEDURES

None.

25-30-01 GALLEY WASTE RECEPTACLES ACCESS DOORS/COVERS

Placard Waste Door Assembly "INOP".

OPERATIONAL PROCEDURES

According to MEL remarks.

MAINTENANCE PROCEDURES

May be flight crewmember accomplished. As required to secure the door in the closed position.

25-40-00 EXTERIOR LAVATORY DOOR ASHTRAYS

Register in the appropriate logbook for maintenance actions.

OPERATIONAL PROCEDURES

None.

MAINTENANCE PROCEDURES

None.



MINIMUM EQUIPMENT LIST

EMBRAER 145LR

25-50-01 CARGO RESTRAINT SYSTEMS

Register in the appropriate logbook for reinstallation actions.

OPERATIONAL PROCEDURES

None.

MAINTENANCE PROCEDURES

None.

25-60-02 NON-ESSENTIAL EQUIPMENT AND FURNISHINGS (NEF)

Placard affected Item "INOP".

OPERATIONAL PROCEDURES

As defined by each operator.

MAINTENANCE PROCEDURES

As defined by each operator.

25-60-05 FLIGHT DECK/ATTENDANT FLASHLIGHT HOLDER ASSEMBLIES

Placard affected Flight Deck/Attendant Flashlight Holder Assembly "INOP" or "REMOVED".

OPERATIONAL PROCEDURES

None.

MAINTENANCE PROCEDURES

None.



MINIMUM EQUIPMENT LIST

EMBRAER 145LR

25-60-09 EMERGENCY MEDICAL EQUIPMENT

Register in the appropriate document for necessary actions.

OPERATIONAL PROCEDURES

As required to meet the regulation requirements.

MAINTENANCE PROCEDURES

None.

25-60-10 "FASTEN SEAT BELTS WHILE SEATED" SIGNS OR PLACARD

OPERATIONAL PROCEDURES

None.

MAINTENANCE PROCEDURES

None.

25-61-01 EMERGENCY LOCATOR TRANSMITTER (ELT)

Placard ELT Panel "ELT INOP" or "ELT NOT INSTALLED".

OPERATIONAL PROCEDURES

None.

MAINTENANCE PROCEDURES

Perform TASK 25-61-01-040-801-A (AMM) for system deactivation.

25-64-02 FLOTATION EQUIPMENT (CREW AND PASSENGER)

OPERATIONAL PROCEDURES

None.

MAINTENANCE PROCEDURES

None.



MINIMUM EQUIPMENT LIST

EMBRAER 145LR

ATA CHAPTER 26 FIRE PROTECTION

26-12-00 APU FIRE DETECTION SYSTEM

Placard APU Control Panel "APU FIRE DET INOP - DO NOT USE APU".

OPERATIONAL PROCEDURES

None.

MAINTENANCE PROCEDURES

None.

NOTE: To avoid spurious message, pull the APU FIRE DET circuit breaker and attach a DO-NOT-CLOSE tag to it.

26-14-00 LAVATORY SMOKE DETECTION SYSTEM

Placard Lavatory Door "INOPERATIVE - DO NOT ENTER", if applicable.

OPERATIONAL PROCEDURES

According to the MEL remarks.

MAINTENANCE PROCEDURES

Lavatory Fire Extinguisher Bottle Pressure check:

May be flight crewmember accomplished. Perform TASK 26-25-01-200-801-A (AMM) to inspect and check the Lavatory Waste Auto-Fire Extinguisher Bottle.

26-15-00 BAGGAGE COMPARTMENT SMOKE DETECTION SYSTEM

Placard Fire Detection/Extinguishing Panel "BAGG SMOKE DET INOP".

OPERATIONAL PROCEDURES

According to the MEL remarks.

MAINTENANCE PROCEDURES

None.



MINIMUM EQUIPMENT LIST

EMBRAER 145LR

26-15-10 BAGGAGE COMPARTMENT SMOKE DETECTOR PROTECTIVE BAR

Placard as appropriate.

OPERATIONAL PROCEDURES

None.

MAINTENANCE PROCEDURES

None.

26-21-02 E1 (2) EXBTTLA (B) INOP CAUTION MESSAGES

Placard on associated Engine Fire Detection/Extinguishing Panel "E1 (or 2) EXBTTLA (or B) INOP MESSAGE NOT AVAIL".

OPERATIONAL PROCEDURES

None.

MAINTENANCE PROCEDURES

Engine Fire Extinguishing System Functional Check:

Perform TASK 26-21-00-700-801-A (AMM) for engine fire extinguishing system functional check.

For airplanes Pre-Mod. SB 145-26-0007, if the EICAS message are triggered only when flying above FL 240, going off below such altitude, it may be a spurious message associated with an improper operation of the fire extinguishing bottle pressure switch. In this case, replace the task above by the following check:

- Perform once a continuity and isolation check on the wiring from the GS0827DC to the pin # A-14/ connector J1018 (DAU-2) and from GS0826DC to the pin # A-14/ connector J1020 (DAU-2). Wiring Manual (WM) references 26-21-50 and 26-21-51. Check no fault found.

Engine Fire Extinguishing Bottles Pressure Check:

The respective manometers of the affected extinguisher bottles must be checked before the first flight of each calendar day. For dispatch purpose the fire extinguisher bottles minimum pressure must be higher than values presented on the table below.



MINIMUM EQUIPMENT LIST

EMBRAER 145LR

Temperature		Gauge Pressure Indication Minimum Pressure (psi)
°C	°F	
-54 to -40	-65 to -40	300
-29	-20	350
-18	0	400
-7	20	450
4	40	500
16	60	550
21 to 27	70 to 80	600
38	100	700
49	120	800
60	140	900

26-22-00 APU FIRE EXTINGUISHING SYSTEM

Placard APU Panel "APU FIRE EXTING INOP - DO NOT USE APU".

OPERATIONAL PROCEDURES

None.

MAINTENANCE PROCEDURES

None.

26-22-01 APU EXTBTL INOP CAUTION MESSAGE

Placard APU Fire Detection/Extinguishing Panel "APU EXTBTL INOP NOT AVAIL".

OPERATIONAL PROCEDURES

None.

MAINTENANCE PROCEDURES

Perform TASK 26-22-00-700-801-A or 26-22-00-700-802-A (AMM) for testing the APU Fire Extinguishing System.



MINIMUM EQUIPMENT LIST

EMBRAER 145LR

26-23-00 BAGGAGE COMPARTMENT FIRE EXTINGUISHER SYSTEM

Placard Fire Detection/Extinguishing Panel "BAGG EXTG INOP".

OPERATIONAL PROCEDURES

None.

MAINTENANCE PROCEDURES

None.

26-23-01 PORTABLE FIRE EXTINGUISHER

Placard the associated Portable Fire Extinguisher "INOP" or "REMOVED", near its normal storage place.

OPERATIONAL PROCEDURES

None.

MAINTENANCE PROCEDURES

None.

26-25-00 LAVATORY FIRE EXTINGUISHER SYSTEMS

Placard Lavatory Door "INOPERATIVE - DO NOT ENTER", if applicable.

OPERATIONAL PROCEDURES

Lavatory Smoke Detector System test:

TEST Button PRESS

Check that the following test indications are activated:

- SMOKE red alarm light on the lavatory smoke detector panel.
- Horn activated on lavatory smoke detector panel.
- LAV SMOKE warning message on EICAS.
- Normal operation green light extinguished.

HORN RESET Button..... PRESS

MAINTENANCE PROCEDURES

May be flight crewmember accomplished. Check that lavatory waste receptacle is empty.



MINIMUM EQUIPMENT LIST

EMBRAER 145LR

ATA CHAPTER 27 FLIGHT CONTROLS

27-10-01 AILERON DAMPERS

Placard Aileron Damper "INOP".

OPERATIONAL PROCEDURES

None.

MAINTENANCE PROCEDURES

Aileron Damper Deactivation:

Perform TASK 27-12-03-040-801-A (AMM) for Aileron Damper Deactivation.

Aileron Damper Visual Inspection:

Perform the visual inspection of the affected PCA rod ends and fittings according to the lasted approved revision of the AD 99-05-04.

27-14-00 ROLL TRIM POSITION INDICATION

Placard Roll Trim Switch "POSITION INDICATION INOP".

OPERATIONAL PROCEDURES

Aileron in Neutral Position check:

- Airplane.....DEENERGIZED
- Control WheelsNEUTRAL POSITION
- Ailerons.....NEUTRAL POSITION
- Airplane.....ENERGIZE
- Roll Trim Switch.....RELEASED
- Electric Hydraulic Pumps.....ON
- Control WheelsNEUTRAL POSITION
- Ailerons.....NEUTRAL POSITION

MAINTENANCE PROCEDURES

None.



MINIMUM EQUIPMENT LIST

EMBRAER 145LR

27-15-00 AILERON DISCONNECTION LIGHT

Placard AIL DISC Caution Light "INOP".

OPERATIONAL PROCEDURES

Aileron Mechanical Interconnection check:

Left Control Wheel HOLD FIRMLY IN NEUTRAL POSITION

Right Control Wheel..... TRY TO TURN LEFT AND RIGHT

If relative movement between both control wheels is not observed, then the aileron mechanical interconnection is connected.

MAINTENANCE PROCEDURES

None.

27-21-03 PEDAL ADJUSTMENT MECHANISMS

Placard associated Pedal Adjustment Switch "INOP".

OPERATIONAL PROCEDURES

With seats adjusted, check pedals for full travel. If the extreme pedal positions can not be reached, readjust the seat or report to the maintenance personnel for pedal adjustment.

MAINTENANCE PROCEDURES

- Make sure that the aircraft is safe for maintenance.
- Do not do other tasks on the rudder system.
- Make sure the CB0383 (E5) is opened.
- Remove cockpit underfloor access hatch 123BL (AMM 06-41-01/101).

- In the interconnection pedal assembly, locate the pedal regulator guide. Inside the guide there will be a pedal regulator spindle. Using an 1/4" wrench, turn slowly clockwise or counterclockwise to move the rudder pedal assembly forward or rearward to suit the pilot requirements.

NOTE: Make sure that the 1/4" wrench fits in the protruded end of the spindle to avoid any damage to the component.

- Once finished the adjustment, install cockpit underfloor access hatch 123BL (AMM 06-41-01/101).
- Close CB0383 (E5) and return the airplane back to service.

NOTE: Some airplanes may present a different circuit breaker positioning configuration. Specific configuration may be found in the aircraft Maintenance Manual (AMM).

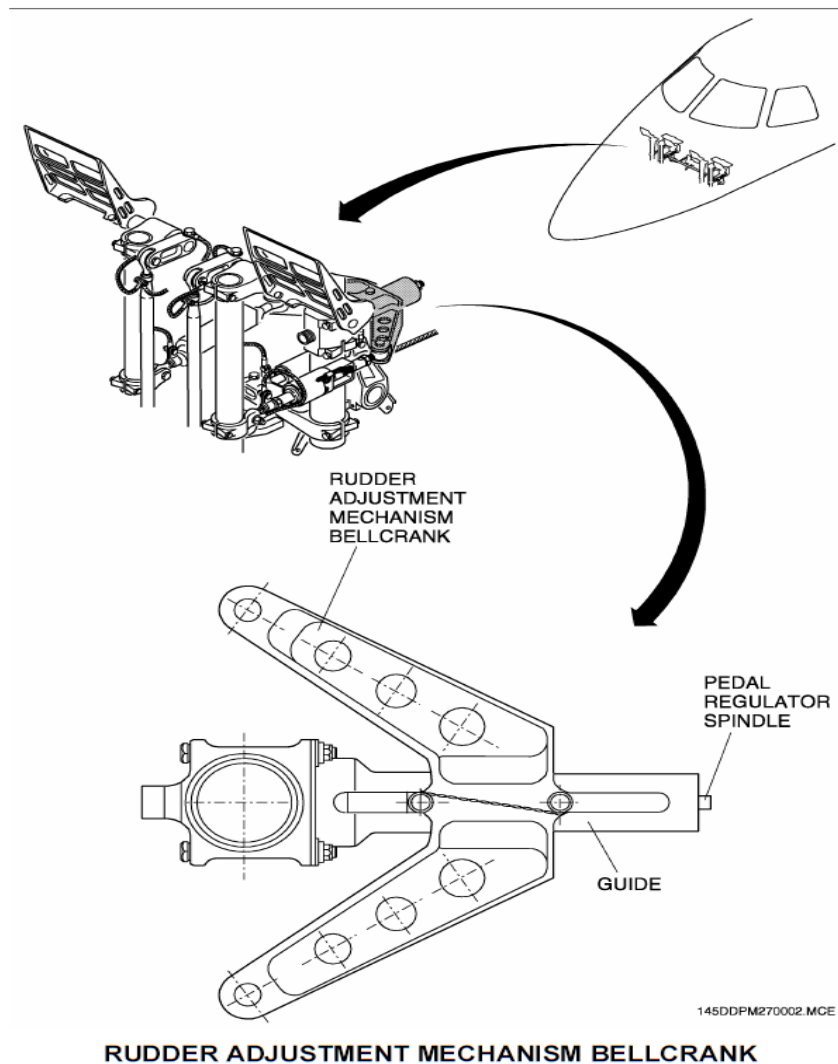



MINIMUM EQUIPMENT LIST

EMBRAER 145LR

27-24-01 YAW TRIM POSITION INDICATIONS

Placard YAW TRIM Knob "INOP".

OPERATIONAL PROCEDURES

Rudder in Neutral Position check:

- Airplane..... DEENERGIZED
- Rudder Pedals NEUTRAL POSITION
- Rudder NEUTRAL POSITION
- Airplane..... ENERGIZE
- Yaw Trim Knob RELEASED
- Electric Hydraulic Pumps..... ON
- Rudder Pedals NEUTRAL POSITION
- Rudder NEUTRAL POSITION

MAINTENANCE PROCEDURES

None.

27-35-00 ELEVATOR DISCONNECTION LIGHT

Placard ELEV DISC Light "INOP".

OPERATIONAL PROCEDURES

Elevator Mechanical Interconnection check:

- Left Control Column HOLD FIRMLY IN NEUTRAL
- Right Control Column..... TRY TO MOVE FORWARD AND BACKWARD

If relative movement between both control columns is not observed, then the elevator mechanical interconnection is connected.

MAINTENANCE PROCEDURES

None.



MINIMUM EQUIPMENT LIST

EMBRAER 145LR

27-36-01 SPS/ICE SPEEDS ADVISORY MESSAGE

Placard SPS/ICE SPEEDS Message "INOP".

OPERATIONAL PROCEDURES

None.

MAINTENANCE PROCEDURES

None.

27-36-03 STICK SHAKERS

Placard Stall Protection System Panel "SHAKER 1 (or 2) INOP".

OPERATIONAL PROCEDURES

None.

MAINTENANCE PROCEDURES

None.

27-27-40-00 MAIN PITCH TRIM SWITCHES

Placard the non-flying pilot side Control Wheel "PITCH TRIM SWITCH
INOP".

OPERATIONAL PROCEDURES

According to the MEL remarks.

MAINTENANCE PROCEDURES

According to the MEL remarks.

27-40-01 PITCH TRIM POSITION INDICATION

Placard near Pitch Trim Cut-out Buttons "POSITION IND INOP".

OPERATIONAL PROCEDURES

Check that stabilizer is correctly set according to CG position by looking at pitch trim marks on vertical stabilizer.

NOTE:

- The thick marks represent, respectively, 4° nose down (top of the scale), neutral, and 10° nose up (bottom of the scale) and each intermediate marks represent a 2° variation (See Figure).
- The airplane can be dispatched in case of: no EICAS indication, pitch trim system operating normally, stabilizer correctly set according to CG position by looking at pitch trim marks on vertical stabilizer, and aural warning TAKEOFF TRIM sounds
- When thrust levers are moved beyond 60°, TAKEOFF TRIM will sound again. Flight crew must confirm that the aural warning is originated from pitch trim position indication inoperative condition.

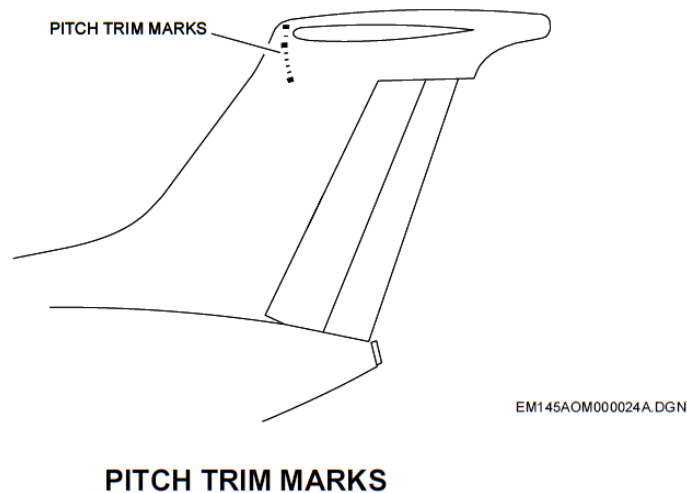
**MAINTENANCE PROCEDURES**

None.

27-53-00 FLAP CHANNELS

Placard near Flap Selector Lever "CHANNEL 1 (or 2) INOP".

OPERATIONAL PROCEDURES

According to the MEL remarks.

MAINTENANCE PROCEDURES

Perform TASK 27-53-00-040-801-A (AMM) for flap channel deactivation.

Note: In order to dispatch with this item inoperative level-off height must be higher than obstacle height.

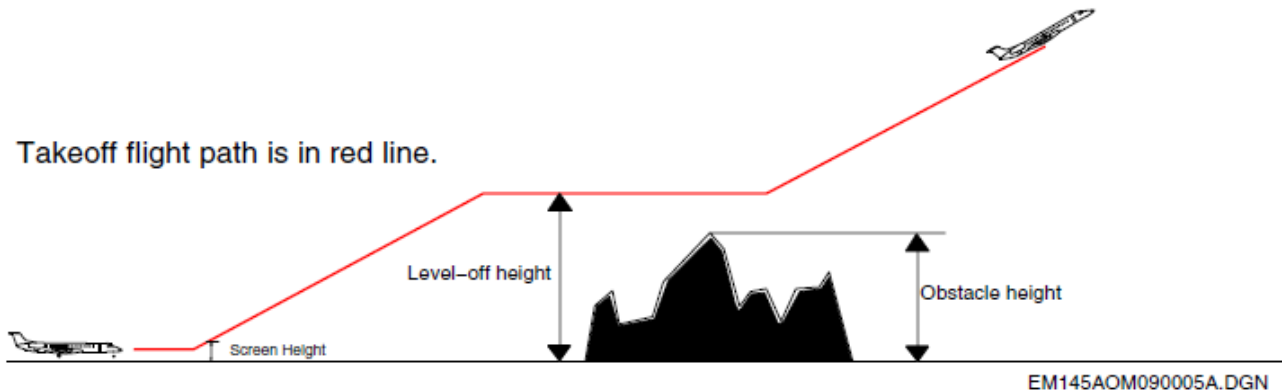

27-70-00 ELECTRO-MECHANICAL GUST LOCK SYSTEM

For airplanes equipped with Electromechanical Gust Lock System:

Placard Gust Lock Lever "INOP" and/or placard affected Gust Lock Amber Light "LIGHT INOP".

OPERATIONAL PROCEDURES

Carefully check elevators are free to move from full forward to full rearward positions. Obtain confirmation from maintenance personnel to check surface full travel.

MAINTENANCE PROCEDURES

For airplanes equipped with Electromechanical Gust Lock System:

- Pull the Air/Ground D circuit breaker (A29) and attach a DO-NOTCLOSE tag to it.
- Move the gust lock lever to unlocked position (full forward).

- If the lever does not move:
 - Perform TASK 27-71-06-900-801-A (AMM) to manually unlock the electromechanical Gust Lock.
 - If the solenoid rod cannot be moved, perform TASK 27-71-06-000-801-A (AMM) to remove the Gust Lock solenoid.
 - After moving the Gust Lock lever to unlocked position, perform TASK 27-71-06-400-801-A (AMM) to install the Gust Lock solenoid.
- Move the control column backward and forward full stroke.
 - If the control column cannot be moved: Perform TASK 27-71-00-200-801-A (AMM) to do a detailed visual inspection on the electromechanical Gust Lock mechanism. Check for broken, locked or jammed parts.
 - Perform TASK 27-71-01-000-801-A (AMM) to remove the electromechanical Gust Lock actuator located at the tail torque box.
 - Perform TASK 27-71-07-400-801-A (AMM) to install the Gust Lock actuator locking device to keep the locking pins in the unlocked position.
- With the gust lock in the unlocked position, move the control columns forward (nose down) and try to move the gust lock lever to locked position.

NOTE: The gust lock lever can not be moved from unlocked position to locked position.

- If the lever moves to the locked position [perform TASK 27-71-00-700-802-A \(AMM\)](#) to assure the Electromechanical Gust Lock Solenoid alignment.
- Pull and collar the Gust Lock circuit breaker (F24) to prevent an inadvertent actuation of the gust lock in flight.
- The GUST LOCK Amber Lights will illuminate and must be masked.
- Push back in the Air/Ground D circuit breaker (A29) and remove the DO-NOT-CLOSE tag from it.

NOTE: - To avoid damage to the flight control system when the gust lock is disengaged, the airplane must be parked in areas not subjected to gust, such as inside a hangar.

- In case of airplane parked in an open area, install the rig pin in the elevator rear sector (see figure) or secure the elevator by other alternate means approved by local authorities.
- Perform TASK 05-50-26-200-802-A before the reactivation and/or takeoff if the airplane is blown with any wind velocity values on ground with Gust Lock system inoperative and with the elevator rig pin not installed.
- Perform TASK 05-50-26-200-802-A if the airplane was exposed to wind velocities higher [than 65 kt.](#)
- Remove rig pin before flight.
- Monitor control column during taxi, in case of any control column unusual movement (full backward or full forward control), the airplane shall return to gate for further maintenance inspection.



MINIMUM EQUIPMENT LIST

EMBRAER 145LR

For airplanes equipped with Gust Lock Lever Movable Stop (Post-Mod SB 145-27-0126):

- Move and hold the movable stop to one of the edges of the crossbar.
- Install a cable tie to the crossbar to hold the movable stop in position.
- Move the Gust Lock to the LOCKED position. Make sure that one thrust lever is able to be moved and the other is blocked by the movable stop.

NOTE: only for XA-NFP, XA-SFH, XA-EFH, XA-JFH, XA-AFH, XA-MAF & XA-PFL aircrafts.

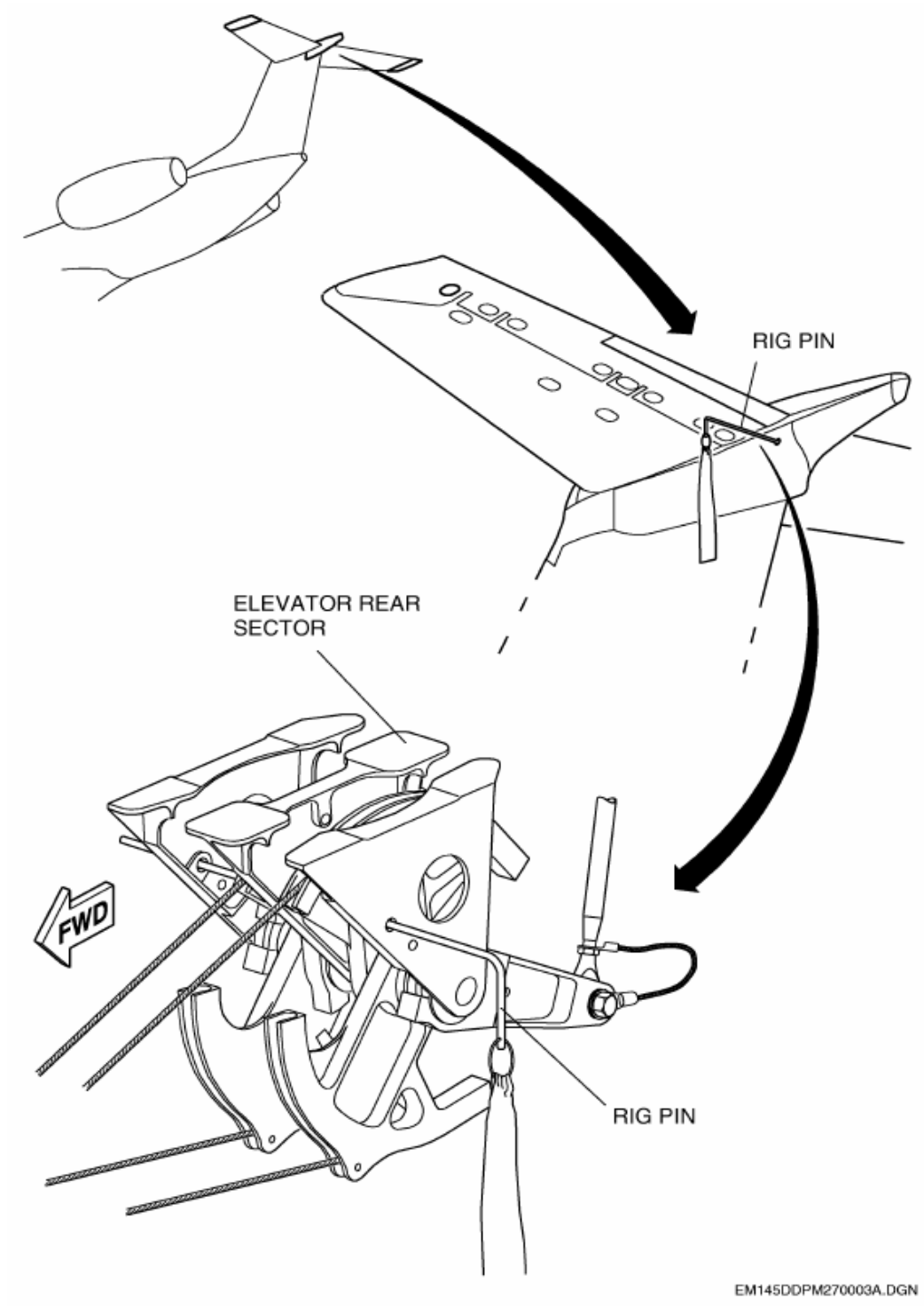

RIG PIN (GSE 058) (ELEVATOR REAR SECTOR)



MINIMUM EQUIPMENT LIST

EMBRAER 145LR

ATA CHAPTER 28 FUEL

28-11-02 SUMP DRAIN VALVES

Placard affected Drain Valve Panel "INOP".

OPERATIONAL PROCEDURES

None.

MAINTENANCE PROCEDURES

Check visually the affected valve for no evidence of leakage and no water contamination in the other associated tank. Perform TASK 12-11-03-600-801-A (AMM).

28-11-05 FUELING RECEPTACLE CAP

Placard near Refueling Receptacle "CAP REMOVED".

OPERATIONAL PROCEDURES

None.

MAINTENANCE PROCEDURES

May be flight crewmember accomplished. Before refueling check the receptacle. Make sure there is no contamination. After refueling makes sure there is no evidence of leakage.



MINIMUM EQUIPMENT LIST

EMBRAER 145LR

28-21-01 WING TANK ELECTRIC FUEL BOOSTER PUMPS

Placard affected Fuel Pump Selector Knob "PUMP A or B or C INOP".

OPERATIONAL PROCEDURES

ELEC EMERG ABNORMAL Message check:

If GPU is available:

- GPUON
- ESSENTIAL POWER Button..... PRESS
- ELEC EMERG ABNORMAL Message CHECK ON
- ESSENTIAL POWER Button..... RELEASE
- ELEC EMERG ABNORMAL Message CHECK OFF

If GPU is not available:

- APU or ENGINE (only one) START
- APU or ENGINE Generator ON
- ESSENTIAL POWER Button..... PRESS
- ELEC EMERG ABNORMAL Message CHECK ON
- ESSENTIAL POWER Button..... RELEASE
- ELEC EMERG ABNORMAL Message CHECK OFF

If any electric fuel booster pump is inoperative, the unusable fuel quantity in the associated wing raises as presented in the table below.

Therefore, additional fuel should be considered for flight planning purposes.

AIRPLANE MODEL	EMB-145 LR
Unusable fuel quantity	Up to 203 liters (364 lb)



MINIMUM EQUIPMENT LIST

EMBRAER 145LR

MAINTENANCE PROCEDURES

May be flight crewmember accomplished.

Electric Fuel Booster Pump Deactivation procedure:

In the DC distribution boxes, open and safe the affected Electric Fuel Booster Pump power circuit breakers:

DISTRIBUTION BOX	PUMP	CIRCUIT BREAKER
LEFT SIDE	1A	A3
	1C	C4
	2B	A4
RIGHT SIDE	1B	A2
	2A	A3
	2C	C4

NOTE: - Some airplanes may present a different circuit breaker positioning configuration. Specific configurations may be found in the Aircraft Maintenance Manual (AMM).

- Pulling the circuit breaker on the distribution box deactivates the pump but may not change the MFD indications (e.g. a deactivated pump still shows indications if it is selected). Ensure the selected pump on the overhead panel is not the deactivated pump.



MINIMUM EQUIPMENT LIST

EMBRAER 145LR

28-21-02 WING TANK ELECTRIC FUEL BOOSTER

PUMP OPERATING INDICATIONS

Placard affected Fuel Pump Selector Knob "PUMP A (or B or C) IND INOP".

OPERATIONAL PROCEDURES

None.

MAINTENANCE PROCEDURES

May be flight crewmember accomplished.

Electric Fuel Booster Pump normal operation check:

- Airplane.....ENERGIZE
- Wing Tanks.....NOT EMPTY
- Associated EngineSTART
- MFD Fuel Page..... SET
- Affected PumpSELECT
- Perform the following check:
 - No MFD pump operation indication.
 - No FUEL LO PRESS displayed on the EICAS caution message.
 - No CAUTION light or aural caution alarm.
- Affected Pump Circuit Breaker PULL
- Perform the following check:
 - Associated caution message displayed on the EICAS.
 - Master Caution light blinking.
 - Aural Warning sounding.
 - MFD indication changing to another pump.
- Affected Pump Circuit Breaker CLOSE
- Check the airplane returning to the original condition.



MINIMUM EQUIPMENT LIST

EMBRAER 145LR

28-22-01 APU FUEL SHUTOFF VALVE

Placard APU Panel "APU FUEL SHUTOFF VALVE INOP - DO NOT USE APU".

OPERATIONAL PROCEDURES

According to the MEL remarks.

MAINTENANCE PROCEDURES

Perform TASK 28-22-01-040-801-A (AMM) for APU Fuel Shutoff Valve secured closed.

28-23-00 PRESSURE DEFUELING / REFUELING SYSTEM

Placard Refueling Panel "PRESSURE DEFUELING/REFUELING INOP".

OPERATIONAL PROCEDURES

Operational procedure associated with overfilling condition Overfilling Condition:

An overfilling condition exists if during the pressure refueling operation there are:

- Fuel leakage through the tank ventilation point,

Wing Tank Fuel Consumption Procedure:

The following procedure should be performed on ground if the corresponding maintenance defueling procedure is not practical or possible to be done.

Overfilling in One Tank: With the crossfeed selector knob in **LOW1** position (right wing tank overfilling) or in the **LOW2** position (left wing tank overfilling) run both engines in IDLE:

- During 15 minutes, or
- Until the fuel quantity indicated on EICAS/MFD is at or below the values presented in table 1.

Overfilling in Both Tanks: With the crossfeed selector knob in **OFF** position, run both engines in IDLE:

- During 30 minutes, or
- Until the fuel quantity indicated on EICAS/MFD is at or below the values presented in table 1.

Check the fuel balancing between the tanks.



MINIMUM EQUIPMENT LIST

EMBRAER 145LR

MAINTENANCE PROCEDURES

Maintenance procedures not associated with overfilling condition Wing Tank Gravity Refueling Procedure:

Perform TASK 12-11-02-600-801-A (AMM) for Wing Tank Gravity Refueling.

Wing Tank Gravity Defueling Procedure:

Perform TASK 12-11-02-600-802-A (AMM) for Wing Tank Gravity Defueling.

Maintenance procedures associated with overfilling condition Overfilling Condition:

An overfilling condition exists if during the pressure refueling operation there are:

- Fuel leakage through the tank ventilation point,

Wing Tank Defueling Procedure if overfilling condition exists:

Perform TASK 12-11-02-600-802-A (AMM) for Gravity Defueling to remove excess fuel from the wing tanks until the fuel quantity is at or below the values presented in table 1.

Check the fuel balancing between the tanks.

TABLE 1 - WING TANK FUEL QUANTITY LIMIT

(NOT PPLICABLE TO GRAVITY REFUELING OPERATION)

COCKPIT/REFUELING PANEL INDICATION				
FUEL TEMP	FUEL TANK QUANTITY (kg)		FUEL TANK QUANTITY (lb)	
(°C)	WING (STD, ER, EP, MP)	WING (LR)	WING (STD, ER, EP, MP)	WING (LR)
-40	2030	2530	4480	5570
-35	2030	2520	4460	5550
-30	2020	2510	4440	5520
-25	2010	2490	4420	5500
-20	2000	2480	4400	5480
-15	1990	2470	4380	5450
-10	1980	2460	4360	5430
-5	1970	2450	4340	5400
0	1960	2440	4320	5380
5	1950	2430	4300	5350
10	1940	2420	4280	5330
15	1930	2400	4260	5300
20	1930	2390	4240	5280
25	1920	2380	4220	5250
30	1910	2370	4200	5230
35	1900	2360	4180	5200
40	1890	2350	4160	5180
45	1880	2340	4140	5150
50	1870	2330	4120	5130
52	1870	2320	4120	5120

Check fuel tank temperature on MFD Fuel Page before using the table.

NOTE: Refueling Completion by gravity is allowed if required.



MINIMUM EQUIPMENT LIST

EMBRAER 145LR

28-23-07 DEFUELING SHUTOFF VALVE

Placard Refueling Panel "DEFUELING SHUTOFF VALVE INOP".

OPERATIONAL PROCEDURES

None.

MAINTENANCE PROCEDURES

Perform TASK 28-23-07-040-801-A (AMM) for Defueling Shutoff Valve secured closed.

NOTE: The EICAS caution message DEFUEL NOT CLOSED may be displayed.

28-23-08 FUEL QUANTITY INDICATOR (REFUELING PANEL)

Placard Refueling Panel "QUANTITY INDICATOR INOP".

OPERATIONAL PROCEDURES

Refer to AOM EMB-145 - Volume I - Section 1-12-25 for gravity refueling. Monitor fuel quantity indication on MFD and EICAS or with the direct measuring sticks.

MAINTENANCE PROCEDURES

Perform TASK 12-11-02-600-801-A (AMM) for Fuel Tank Gravity refueling.

28-40-00 WING TANK FUEL QUANTITY INDICATIONS (EICAS AND MFD)

Placard MFD or PFD Bezel "FUEL QTY IND INOP".

OPERATIONAL PROCEDURES

If the Fuel Quantity Gauging and Indication System of one wing tank is inoperative, the associated indication will present unreliable information on the EICAS display. On the MFD Fuel Page, both the associated tank indication and the TOTAL fuel quantity will present unreliable information. The EICAS caution message FUEL IMBALANCE may be also presented.

Wing tanks fuel quantity can be measured on ground, through the Direct Measuring Stick System, described on the AOM EMB-145 - Description System - Volume II - Section 2-08-15.

In flight, the aircraft Remaining Fuel Quantity can be determined through the information from the: Flight Card Required/Filled Fuel, FMS fuel data, Fuel Used (FU) of the MFD Fuel Page and the Fuel Flow (FF) of the EICAS/RMU/EFIS.

When one wing tank fuel quantity indication is inoperative, both the Fuel Flow (FF) and the Fuel Used (FU) shall be monitored throughout the whole flight.



MINIMUM EQUIPMENT LIST

EMBRAER 145LR

NOTE: In case of fuel tank level too high to be measured by the measuring sticks, it may be necessary to have the airplane topped off by gravity refueling.

MAINTENANCE PROCEDURES

None.

28-42-01 DIRECT QUANTITY MEASURING STICKS

Placard Refueling Panel "DIRECT QTY MEASURING STICKS INOP".

OPERATIONAL PROCEDURES

Check the remaining sources of fuel quantity information such as fuel quantity indications on EICAS and MFD Fuel Page, fuel quantity indicator in refueling panel and fuel loaded.

MAINTENANCE PROCEDURES

None.

28-43-00 FUEL TANK TEMPERATURE INDICATION SYSTEM

Placard MFD Bezel "FUEL TANK TEMP IND INOP".

OPERATIONAL PROCEDURES

None.

MAINTENANCE PROCEDURES

None.

28-44-00 FUEL 1 (OR 2) LO LEVEL MESSAGE

Placard EICAS Bezel "FUEL 1 (or 2) LO LEVEL MESSAGE INOP".

OPERATIONAL PROCEDURES

None.

MAINTENANCE PROCEDURES

None.



MINIMUM EQUIPMENT LIST

EMBRAER 145LR

28-45-01 E1 (OR 2) FUEL LO PRESS MESSAGE

Placard EICAS Bezel "FUEL 1 (or 2) LO PRESS MESSAGE INOP".

OPERATIONAL PROCEDURES

Fuel Booster Pump Automatic Function Operation check:

- Airplane..... ENERGIZE
- Associated Engine START
- MFD Fuel Page..... SET
- 1A (2A) Fuel Pump SELECT

- The MFD shows A for TANK1 (TANK2).

- 1A (2A) Fuel Pump

Circuit Breaker A1 (A34)..... OPEN

- On the MFD, the indication of the related tank changes to B, C, and OFF intermittently.

- 1A (2A) Fuel Pump

Circuit Breaker A1 (A34)..... CLOSE

- The A indication comes into view on the MFD again.

- Repeat the steps above for 1B (2B) and 1C (2C) fuel pumps.

Ensure that on the MFD the indication of the related tank changes to A, C and OFF intermittently and A, B and OFF intermittently.

Register on appropriate logbook for maintenance actions.

MAINTENANCE PROCEDURES

None.



MINIMUM EQUIPMENT LIST

EMBRAER 145LR

28-45-02 APU FUEL LOW PRESS SWITCH

Placard APU Control Panel "APU FUEL LO PRESS SWITCH INOP - DO NOT USE APU", if applicable.

OPERATIONAL PROCEDURES

Engine 2 Fuel Low Pressure Indication check:

- Airplane.....ENERGIZE
- Engine 2.....START
- MFD Fuel PageSET
- 2A Fuel Pump.....SELECT
- Perform the following check:
 - MFD shows A for tank 2.
 - No caution message FUEL LO PRESS displayed on the EICAS.
 - No caution light or no aural caution alarm.
 - 2A Fuel Circuit Breaker (A34).....PULL
 - Check the indication of the related tank changes to B, C and OFF intermittently on the MFD.
 - 2A Fuel Circuit Breaker (A34).....CLOSE
 - Select the 2B fuel pump and repeat the procedure.
 - Select the 2C fuel pump and repeat the procedure.

MAINTENANCE PROCEDURES

None.

ATA CHAPTER 29 HYDRAULIC POWER**29-10-02 GSE COUPLINGS (EXTERNAL)**

Placard the affected Plumbing "GSE COUPLING ISOLATED OR REMOVED".

OPERATIONAL PROCEDURES

None.

MAINTENANCE PROCEDURES

Perform TASK 29-10-02-040-801-A (AMM) for GSE Pressure Coupling removal and install and install plugs MS21913W8 (or MS21913J8) and MS21913J5 on hydraulic lines (See figure below).

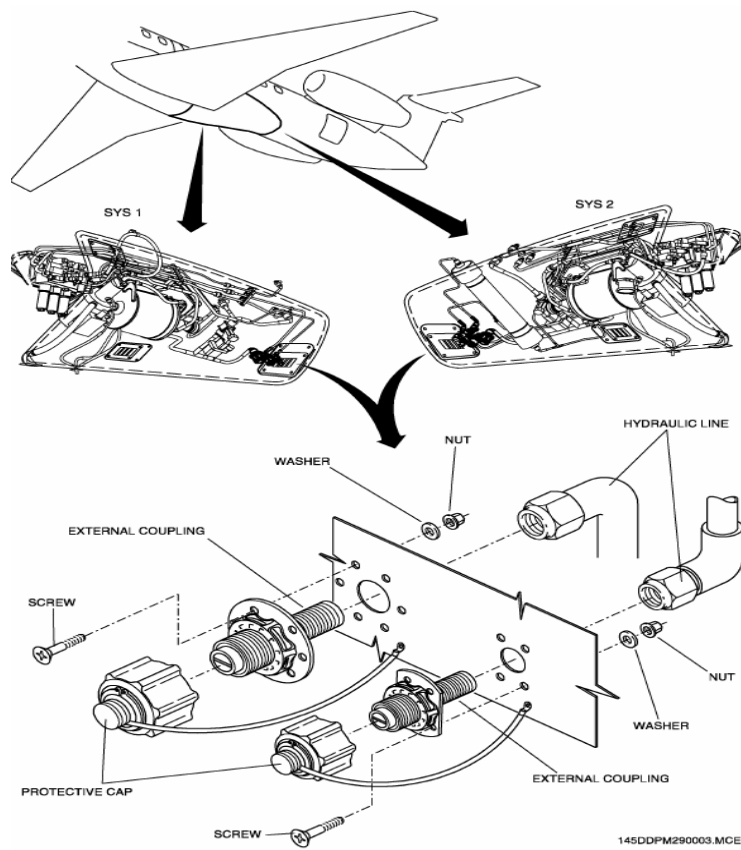



MINIMUM EQUIPMENT LIST

EMBRAER 145LR

29-10-05 ELECTRIC HYDRAULIC PUMP SYSTEMS

Placard affected Electric Hydraulic Pump Control Knob "AUTO INOP" or "ON INOP".

OPERATIONAL PROCEDURES

In case of the automatic function failure, the affected pump must be turned off during cruise after gear retraction and back on prior to landing gear extension.

Pressure Indication and Electric Pump Pressure Switch check:

Before Associated Engine Start:

- Associated ELEC PUMP Knob..... OFF
- MFD 1 or 2..... HYD PAGE
- MFD Pump Status Indication CHECK OFF
- MFD Hyd. Pressure Indication..... CHECK AROUND ZERO
- Associated ELEC PUMP Knob..... ON
- MFD Pump Status Indication CHECK ON
- MFD Hyd. Pressure Indication..... CHECK WITHIN 2900 ± 200 psig
- Associated ELEC PUMP knob..... OFF



MINIMUM EQUIPMENT LIST

EMBRAER 145LR

OFF and AUTO Position check (Manual Function Inoperative):

With associated engine shutdown:

- Associated ELEC PUMP Knob.....OFF
- MFD 1 or 2.....HYD PAGE
- MFD Pump Status Indication.....CHECK OFF
- Associated ELEC PUMP Knob.....AUTO
- MFD Pump Status Indication.....CHECK ON
- Associated Engine.....START

During associated engine START:

- N2BELOW 56%
- MFD Pump Status Indication.....CHECK ON
- N2ABOVE 56%
- MFD Pump Status Indication.....CHECK OFF

After associated engine START:

- Associated ENG PUMP SHUTOFF

ButtonPRESS

- MFD Pump Status Indication.....CHECK ON

- Associated ENG PUMP SHUTOFF

ButtonRELEASE

- MFD Pump Status Indication.....CHECK OFF

MAINTENANCE PROCEDURES

None.

29-10-14 RESERVOIR REFILLING CHECK VALVES

Placard the affected Plumbing "CHECK VALVE REMOVED".

OPERATIONAL PROCEDURES

None.

MAINTENANCE PROCEDURES

Perform TASK 29-10-14-040-801-A (AMM) for Check Valve removal and install plug MS21913W4 or MS21913J4 on hydraulic line (See figure below).

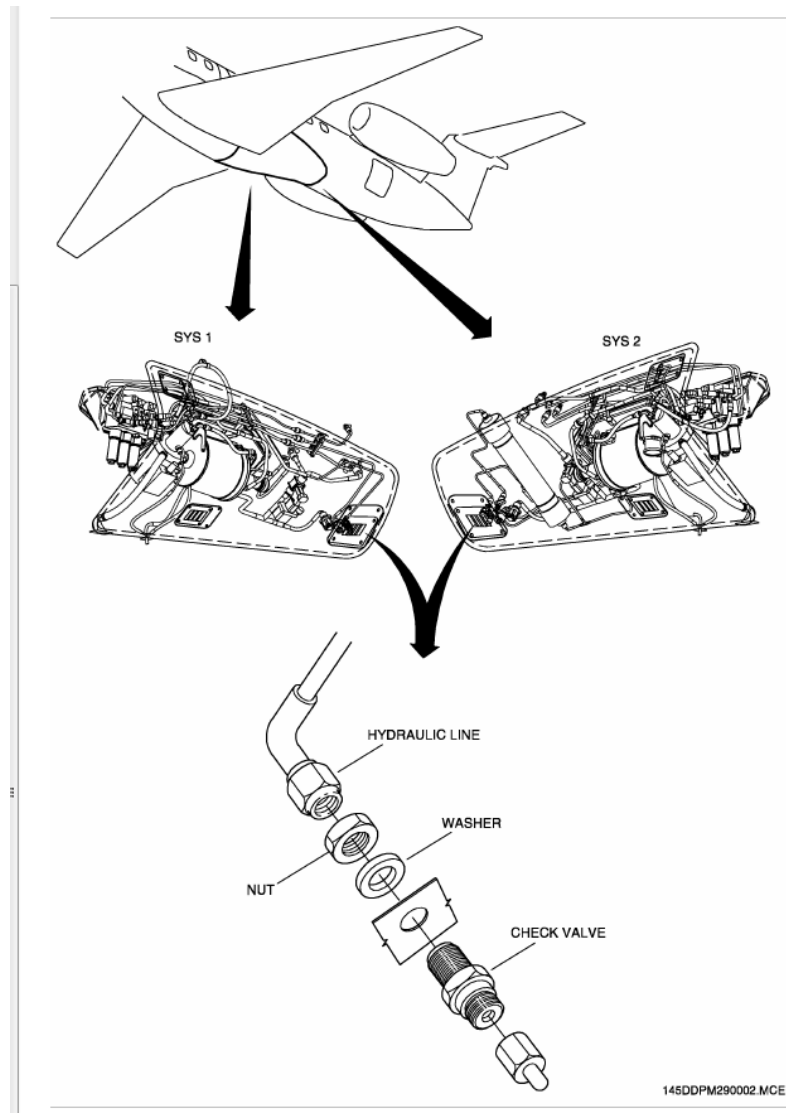

29-10-16 PRESSURE GROUND CONNECTION CHECK VALVES

Placard the affected Plumbing "CHECK VALVE REMOVED".

OPERATIONAL PROCEDURES

None.

MAINTENANCE PROCEDURES

Perform TASK 29-10-16-040-801-A (AMM) for Check Valve removal and install plugs MS21913J6 or MS21913W6 and O'ring NAS1612-6 on hydraulic line (See figure below).

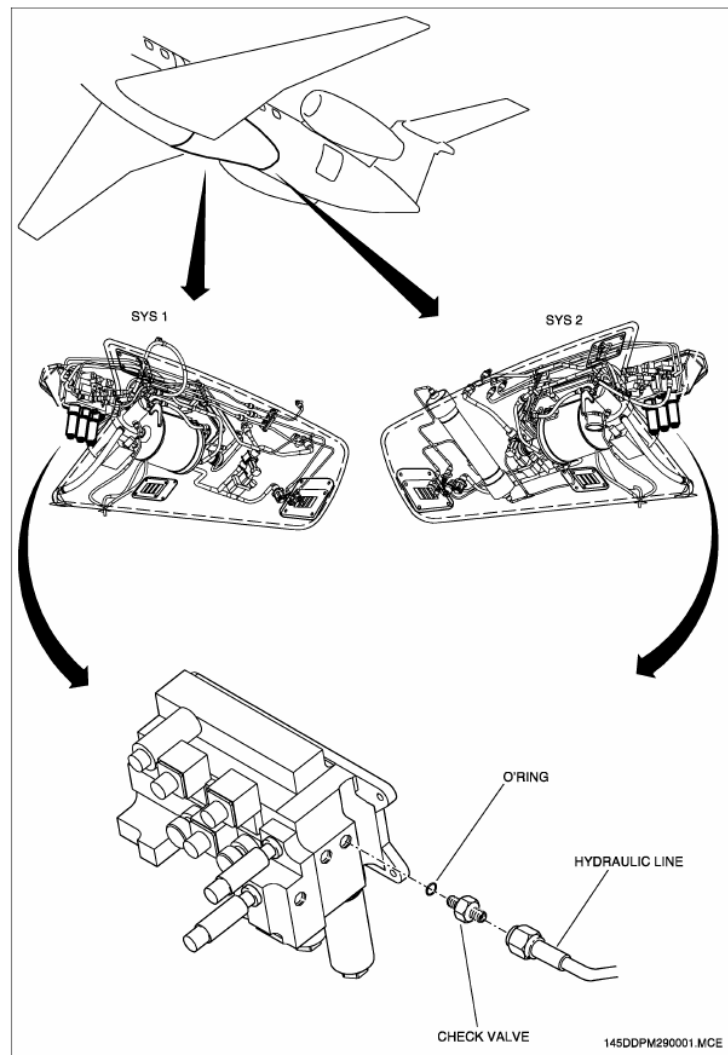



MINIMUM EQUIPMENT LIST

EMBRAER 145LR

29-10-19 ENGINE-DRIVEN PUMP PRESSURE SWITCH (HYDRAULIC SYSTEM 1)

Placard affected plumbing "PRESSURE SWITCH REMOVED".

OPERATIONAL PROCEDURES

Pressure Indication and Electric Pump Pressure Switch check:

Before Associated Engine Start:

- Associated ELEC PUMP Knob..... OFF
- MFD 1 or 2..... HYD PAGE
- MFD Pump Status Indication CHECK OFF
- MFD Hyd. Pressure Indication..... CHECK AROUND ZERO
- Associated ELEC PUMP Knob..... ON
- MFD Pump Status Indication CHECK ON
- MFD Hyd. Pressure Indication..... CHECK WITHIN 2900 ± 200 psig
- Associated ELEC PUMP knob..... OFF

MAINTENANCE PROCEDURES

In case of fluid leakage, perform TASK 29-10-19-040-801-A (AMM) for pressure switch deactivation.

29-30-00 HYDRAULIC FLUID QUANTITY INDICATIONS (INCLUDING LOW LEVEL WARNING)

Placard MFD Bezel "HYD QTY IND INOP".

OPERATIONAL PROCEDURES

None.

MAINTENANCE PROCEDURES

Perform TASK 12-13-01-600-801-A (AMM) for Hydraulic Fluid

Quantity check.



MINIMUM EQUIPMENT LIST

EMBRAER 145LR

29-30-01 RESERVOIR QUANTITY GAGES

Placard affected Gage "INOP".

OPERATIONAL PROCEDURES

None.

MAINTENANCE PROCEDURES

Alternate Fluid Quantity check:

- Gain access to the affected reservoir (193BL or 193CR panel) (See figures 103 and 104 (AMM 06-41-01/101) for positive identification).
- Remove the vent filter (cut the lockwire and remove both screws).
- Ensure Landing Gear/Main Door and Emergency/Parking Brake accumulators have a pre-charge of nitrogen only (refer to AMM TASK 32-44-02-700-801-A SUBTASK 32-44-02-720-001-A00 and TASK 52-12-00-700-802-A SUBTASK 52-12-00-720-001-A00).
- Insert a small rod in the vent filter hole deep enough to contact the piston head (in order to measure piston displacement).
- Make sure piston displacement is at or below 30 mm.
- If displacement is above 30 mm, perform TASK 12-13-01-600-802-A (AMM) to replenish the reservoir.
- Install and lockwire the vent filter.

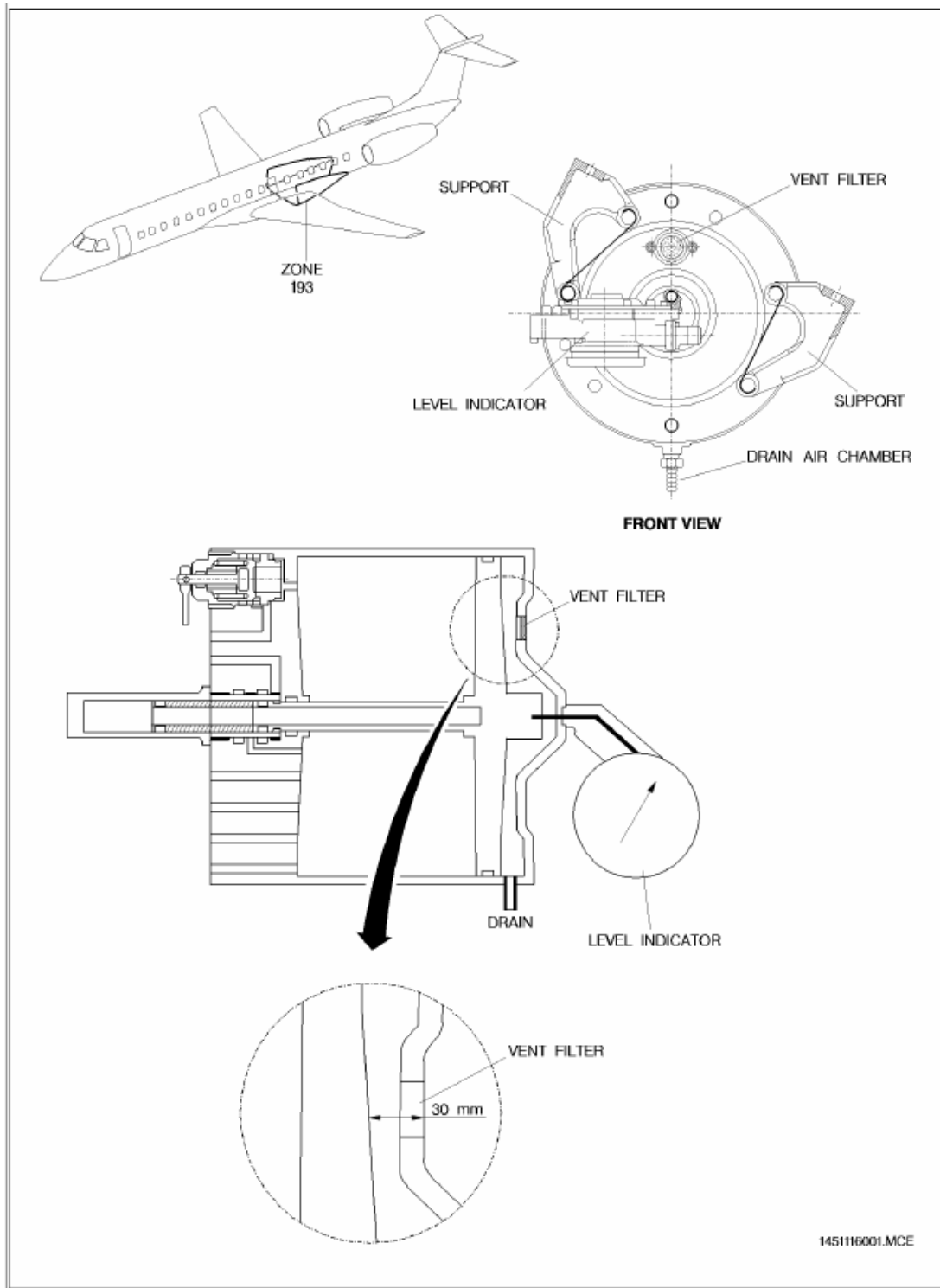



MINIMUM EQUIPMENT LIST

EMBRAER 145LR

29-30-02 HYDRAULIC PRESSURE INDICATIONS

Placard MFD Bezel "HYD SYS 1 (OR 2) PRESS IND INOP".

OPERATIONAL PROCEDURES

HYD SYS FAIL Caution Message operation check:

- Landing Gear Ground Locking Pins INSERT
- Associated Engine..... START
- Air/Ground Circuit Breakers (A5, A29, E17 and E18) PULL
- Associated ELEC PUMP knob OFF
- Associated ENG PUMP SHUTOFF Button PRESS
- Associated HYD SYS FAIL Message..... CHECK ON
- Associated ENG PUMP SHUTOFF Button RELEASE
- Air/Ground Circuit Breakers (A5, A29, E17 and E18) CLOSE
- Associated HYD SYS FAIL Message..... CHECK OFF

MAINTENANCE PROCEDURES

None.



MINIMUM EQUIPMENT LIST

EMBRAER 145LR

29-30-04 ELECTRIC PUMP PRESSURE SWITCH (HYDRAULIC SYSTEM 1)

Placard the affected plumbing "PRESSURE SWITCH REMOVED".

OPERATIONAL PROCEDURES

Pressure Indication and Engine Driven Pump Pressure Switch check:

Before associated engine start:

- Associated ELEC PUMP Knob..... OFF
- MFD 1 or 2..... HYD PAGE
- MFD Pump Status Indication CHECK OFF
- MFD Hyd. Pressure Indication..... CHECK AROUND ZERO
- Associated ELEC PUMP Knob..... AUTO
- MFD Pump Status Indication CHECK ON
- MFD Hyd. Pressure Indication..... CHECK WITHIN 2900 ± 200 psig

During associated engine start:- N2 BELOW 56%

- MFD Pump Status Indication CHECK ON
- N2 ABOVE 56%
- MFD Pump Status Indication CHECK OFF

After associated engine start:

- Associated ENG PUMP SHUTOFF Button..... PRESS
- MFD Pump Status Indication CHECK ON (after pressure drops to 1600 psig)
- Associated ENG PUMP SHUTOFF Button..... RELEASE
- MFD Pump Status Indication CHECK OFF

NOTE: After pressing the ENG PUMP SHUTOFF Button, pressure will take a while to drop to a value at which the Electric Pump will be automatically switched ON. This value can be as low as 1250 psig.

MAINTENANCE PROCEDURES

In case of fluid leakage, perform TASK 29-30-04-040-801-A (AMM) for pressure switch removal.



MINIMUM EQUIPMENT LIST

EMBRAER 145LR

ATA CHAPTER 30 ICE AND RAIN PROTECTION

30-11-00 WING ANTI-ICING SYSTEM

Placard Ice Protection Panel "WING SYSTEM INOP".

OPERATIONAL PROCEDURES

None.

MAINTENANCE PROCEDURES

None.

30-11-01 WING ANTI-ICING VALVES

Placard above Wing Anti-icing Button "INOP".

OPERATIONAL PROCEDURES

None.

MAINTENANCE PROCEDURES

Wing/Stabilizer Anti-ice Valve secured closed:

For Airplanes Pre-Mod. SB 145-30-0021:

- Gain access to the valve through respective access panels (191EL - LH side, or 191FR - RH side. See AMM 6-41-01).
- With the position indicator in the STOW position, loosen the lock bolt.
- Rotate the valve to the LOCK position (Align the position indicator hole with the cover assembly threaded hole by using a 1/4" socket or end wrench on the exposed valve shaft).
- Retighten the lock bolt and torque it until there is a 0.25 to 1.25 mm gap between the under side of the bolt head and the top surface of the position indicator.

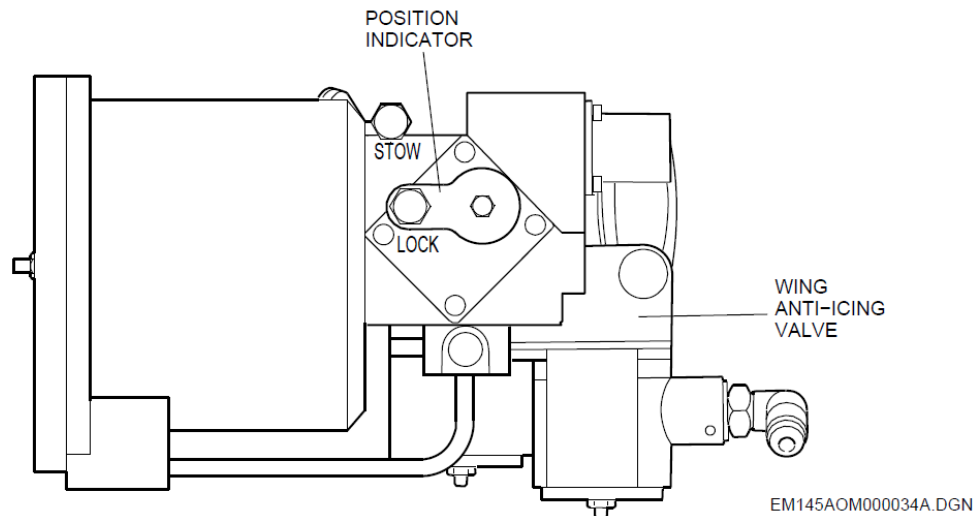

WING/STABILIZER ANTI-ICE VALVE (PRE-MOD. SB 145-30-0021)

For Airplanes Post-Mod. SB 145-30-0021:

- Gain access to the valve through respective access panels (191EL - LH side, or 191FR - RH side. See AMM 6-41-01).
- With the anti-icing valve deenergized, the actuator pressure is vented to ambient and the valve is in the closed position. The position indicator is directed to "CL" on the valve housing.
- Remove the chained lock screw to vent servo and install the screw in the threaded hole (see figure) with the position indicator directed to "CL".
- Rotate the valve to the "CL" position (Align the position indicator hole with the cover assembly threaded hole by using a 1/4" socket or end wrench on the exposed valve shaft).
- Bottom screw in boss and wrench the lock screw to locked position to a maximum of 8 ft-lb.
- For quick reference, locking instructions are printed on the valve instruction plate.

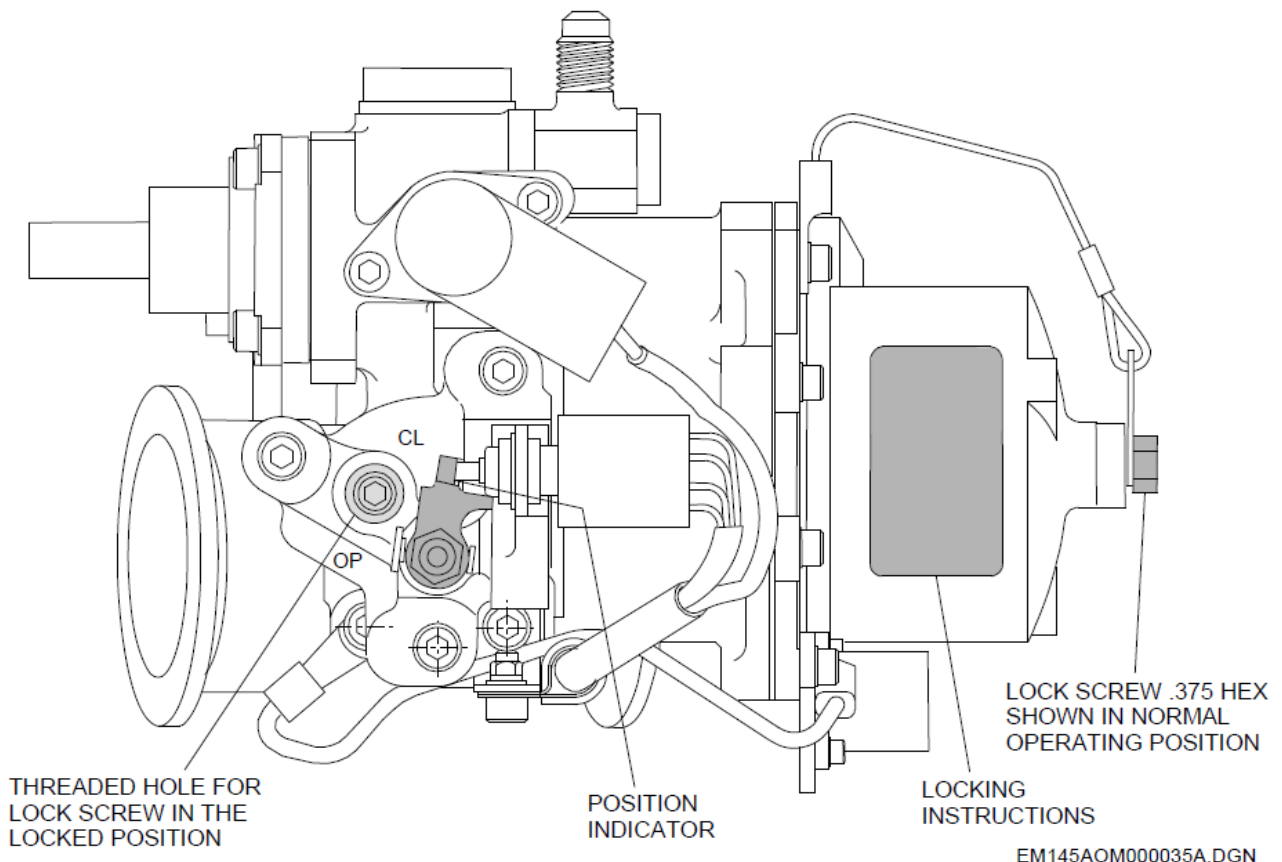

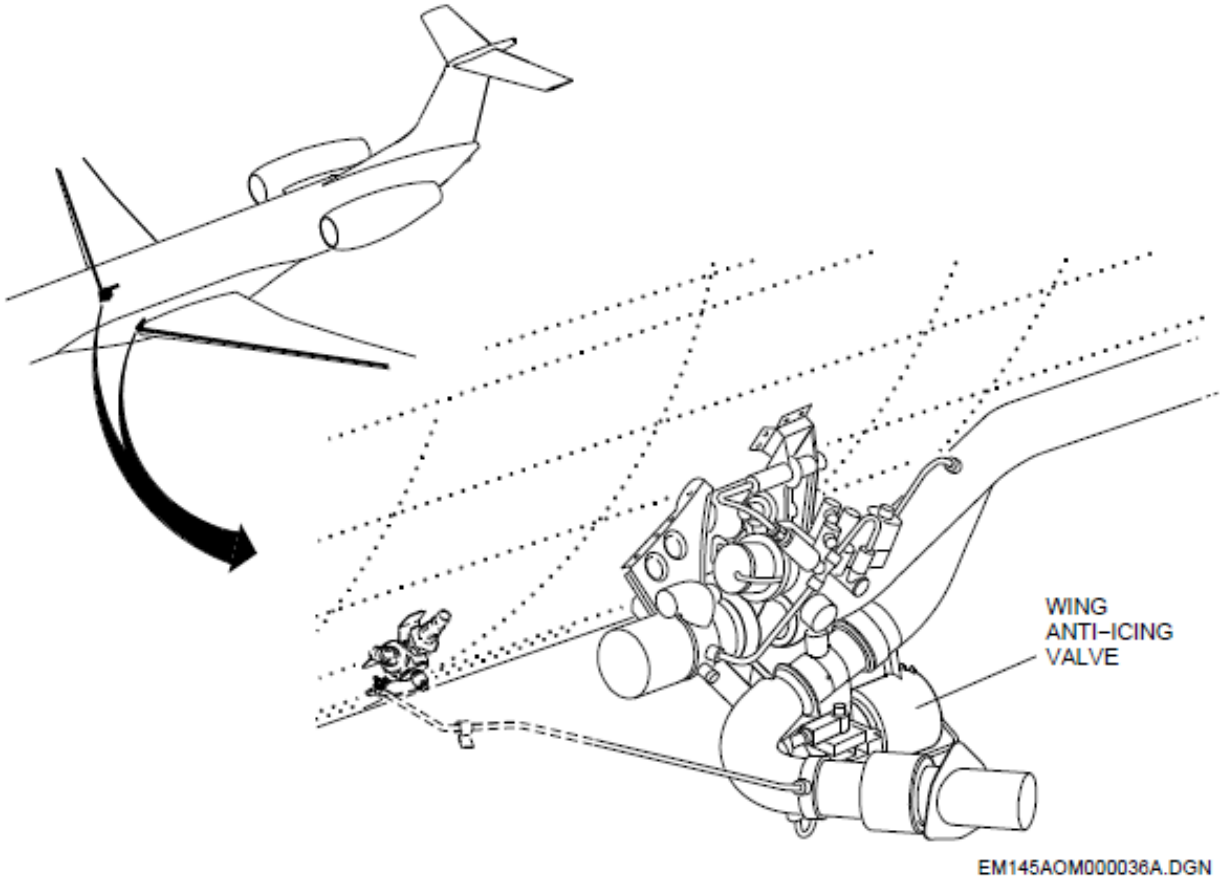

WING ANTI-ICE VALVE LOCATION
(PRE-MOD. AND POST-MOD. SB 145-30-0021)



MINIMUM EQUIPMENT LIST

EMBRAER 145LR

30-11-02 WING ANTI-ICING VALVE OPEN LIGHT

Placard above Wing Anti-Icing Button "OPEN LIGHT INOP".

OPERATIONAL PROCEDURES

None.

MAINTENANCE PROCEDURES

Perform TASK 30-00-00-700-803-A (AMM) for wing thermal anti-icing system operational check.

30-12-00 STABILIZER ANTI-ICING SYSTEM

Placard Ice Protection Panel "STAB. SYSTEM INOP".

OPERATIONAL PROCEDURES

None.

MAINTENANCE PROCEDURES

None.

30-12-01 STABILIZER ANTI-ICING VALVE

Placard above Stabilizer Anti-icing Button "INOP".

OPERATIONAL PROCEDURES

None.

MAINTENANCE PROCEDURES

Refer to item 30-11-01 for valve secured closed procedure. To gain access to this valve, remove access panel 322AL (see AMM 6-42-00).



MINIMUM EQUIPMENT LIST

EMBRAER 145LR

30-12-02 STABILIZER ANTI-ICING VALVE OPEN LIGHT

Placard above Stabilizer Anti-Icing Button "OPEN LIGHT INOP".

OPERATIONAL PROCEDURES

None.

MAINTENANCE PROCEDURES

Perform TASK 30-00-00-700-803-A (AMM) for horizontal stabilizer thermal anti-icing system operational check.

30-21-00 ENGINE ANTI-ICING SYSTEMS

Placard Ice Protection Panel "ENGINE SYSTEM INOP".

OPERATIONAL PROCEDURES

None.

MAINTENANCE PROCEDURES

None.



MINIMUM EQUIPMENT LIST

EMBRAER 145LR

30-21-01 ENGINE ANTI-ICING VALVES

Placard above Engine Anti-icing Button "INOP".

OPERATIONAL PROCEDURES

For airplanes equipped with AE3007A, AE3007A1/1, AE3007A1, AE3007A1E, AE3007A1/3 and AE3007A1P engines - AE3007A and AE3007A1/1 engines intermix operation is also permitted:

The following procedures must be accomplished when dispatching the airplane with one or both engine anti-icing valves locked open:

NOTE: The associated E1 (2) A/ICE FAIL message may be present throughout the flight unless the Ice Detection Override Knob is set to ENG or ALL. If this message persists with the knob in ENG or ALL, follow the associated QRH procedure or report to the maintenance personnel, as applicable.

Takeoff Data Setting:

- Set REF A/I ON, so the FADECs properly command the correct thrust if one or two engine valves are locked open.
- Operate the Ice Detection Override normally: ENG in icing conditions, AUTO not in icing conditions.
- Ref A/I DISAG message will be inhibited only when both engine anti-ice valves are locked open with REF A/I ON and ENG selected, otherwise the message may appear.

Takeoff Weights Corrections:

The takeoff weight correction should be accomplished according one of the following criteria:

- Run the ETOAS with the Anti-ice option set to "FAIL", or
- Reduce the MTOW by:
 - a) 794 lb (AE3007A, AE3007A1/1 or AE3007A1 engines).
 - b) 587 lb (AE3007A1E engine).
 - c) 508 lb (AE3007A1P or AE3007A1/3 engines).

NOTE: - In case of discrepancies between the MTOW calculated through Runway Analysis Software and the MTOW reduced by xx lb (depending on the engine), the value given by Software must prevail.

- For airplanes equipped with AE3007A, AE3007A1/1 and AE3007A1 engines, only T/O-1 mode is allowed for takeoff with engine anti-ice valve locked open.
- For airplanes equipped with AE3007A1P and AE3007A1/3 engines, only T/O mode is allowed for takeoff with engine anti-ice valve locked open.
- For airplanes equipped with AE3007A1E engine, only T/O and E T/O mode are allowed for takeoff with engine anti-ice valve locked open.



MINIMUM EQUIPMENT LIST

EMBRAER 145LR

Speeds Corrections:

There are no speed corrections associated with engine anti-ice valve locked.

Enroute and Landing Weights Corrections:

Use applicable AFM supplement performance charts to calculate enroute and landing weights when operating with engine anti-ice locked open.

MAINTENANCE PROCEDURES

For airplanes equipped with Valves PN C146009-3 or C146009-2:

-Perform [TASK 30-21-05-200-802-A \(AMM\)](#) for Engine Anti-Ice Valve check.

Engine Anti-ice Valve secured open:

- Remove the following access panels (AMM 06-43-00/101):
 - 412AT (Upper cowling of the LH powerplant) and
 - 422AT (Upper cowling of the RH powerplant);
- Loosen both lock screws (approximately one turn);
- Press and rotate the manual override pin 270° as indicated to lock valve in the open position;
- Tighten both lock screws.
- Close the following access panels (AMM 06-43-00/101):
 - 412AT (Upper cowling of the LH powerplant) and
 - 422AT (Upper cowling of the RH powerplant).

NOTE: - The message ENG A/ICE OVERPRES may be present.

- The message ENG NO ICE-A/ICE ON may be present.
- In case of engine anti-ice valve secured open and associated engine anti-icing OPEN light inoperative, the airplane may be dispatched.

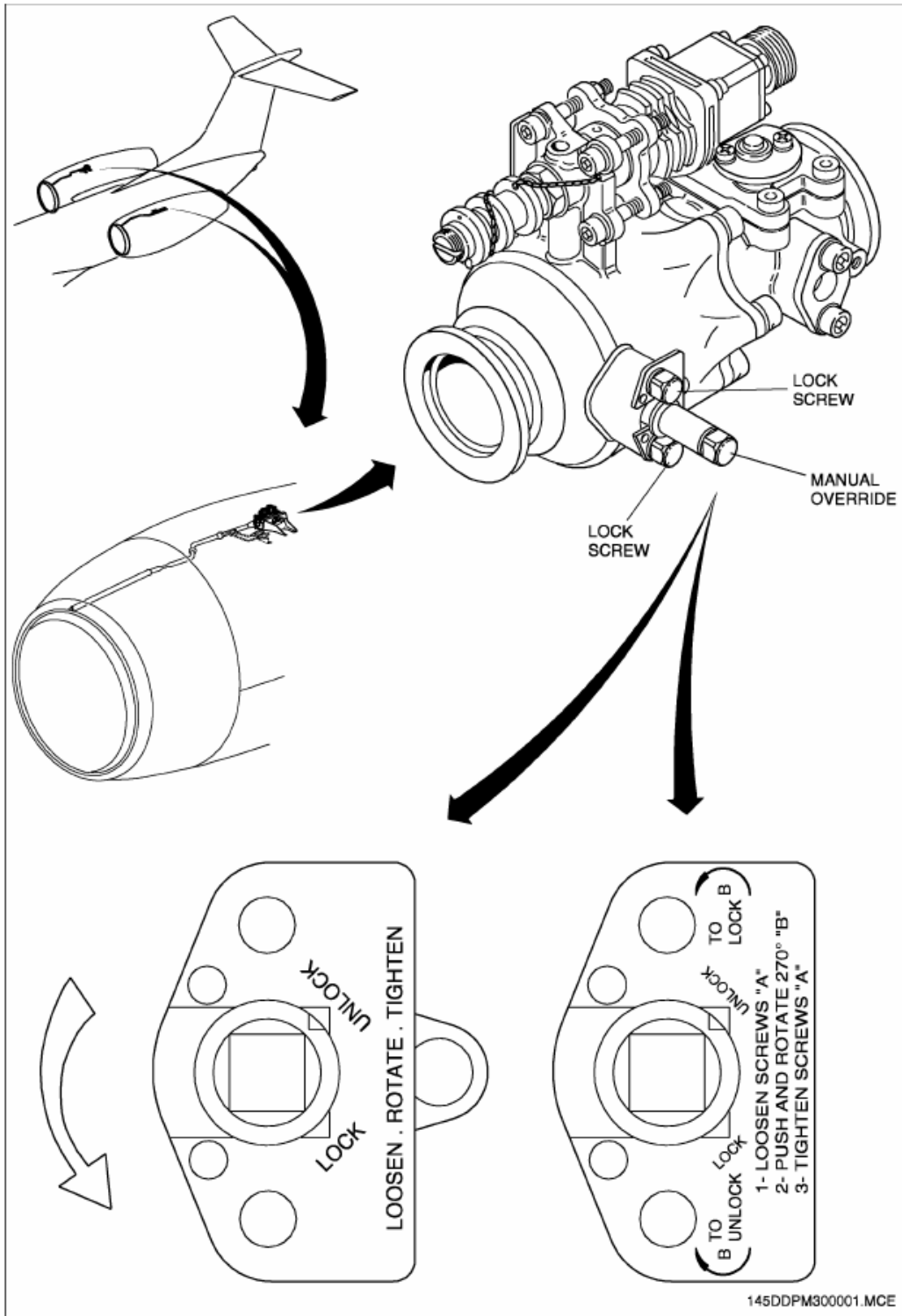

ENGINE ANTI-ICING VALVE



MINIMUM EQUIPMENT LIST

EMBRAER 145LR

30-21-02 ENGINE ANTI-ICING VALVE OPEN LIGHT

Placard above Engine Anti-Icing Buttons "OPEN LIGHT INOP".

OPERATIONAL PROCEDURES

None.

MAINTENANCE PROCEDURES

Perform TASK 20-13-04-000-801-A (AMM) (removal) and TASK 20-13-04-400-801-A (AMM) (installation) to swap the pushbuttons of Engine Air Inlet 1 and Engine Air Inlet 2. After swapping the pushbuttons, perform TASK 30-21-00-700-804-A (AMM) for Engine Anti-Icing Valve Operational Test.

NOTE: The intention of the accomplishment of these tasks above is to confirm the failure of the OPEN indication light and the proper operation of the engine anti-ice valve.

30-31-00 PITOT/STATIC HEATING SYSTEMS

Placard above Pitot/Static Heating Button "PITOT HEAT INOP".

OPERATIONAL PROCEDURES

None.

MAINTENANCE PROCEDURES

NOTE: - For MEL dispatch purposes, the Pitot/Static Heating system is comprised of: Pitot Tube Heating, Pitot/Static Heating and Static Port Heating.

- Pitot System 1 = Pitot 1 (P1) + Static 1 (S1).
- Pitot System 2 = Pitot 2 (P2) + Static 2 (S2).
- Pitot System 3 = P/S3 (pitot +static) (standby).

Pitot/Static Heating Operational Check:

May be flight crewmember accomplished.

After engine start:

Check no caution message associated to the remaining static ports heating after any engine achieves 65% N2.



MINIMUM EQUIPMENT LIST

EMBRAER 145LR

30-31-03 PITOT LINES HEATER

Placard as appropriate.

OPERATIONAL PROCEDURES

None.

MAINTENANCE PROCEDURES

None.

30-32-01 AOA SENSOR HEATING SYSTEMS

Placard above AOA Heating Button "AOA HEAT INOP".

OPERATIONAL PROCEDURES

None.

MAINTENANCE PROCEDURES

None.

30-33-01 TAT PROBE HEATING SYSTEMS

Placard above TAT Heating Button "TAT HEAT INOP".

OPERATIONAL PROCEDURES

None.

MAINTENANCE PROCEDURES

None.

30-41-00 WINDSHIELD WIPERS

Placard Windshield Wiper Selector Knob "INOP" or "LOW INOP" or "HIGH INOP" or "TIMER INOP".

OPERATIONAL PROCEDURES

According to the MEL remarks.

MAINTENANCE PROCEDURES

None.



MINIMUM EQUIPMENT LIST

EMBRAER 145LR

30-41-04 RAIN REPELLENT COATING.

OPERATIONAL PROCEDURES

None.

MAINTENANCE PROCEDURES

None.

30-42-02 WINDSHIELD HEATING SYSTEMS

Placard Windshield Heating Control Panel "SYSTEM INOP".

OPERATIONAL PROCEDURES

None.

MAINTENANCE PROCEDURES

May be flight Crewmember accomplished. Pull and safety the WSHLD TEMP circuit breaker associated with the inoperative windshield (G13 or J20).

30-80-00 ICE DETECTORS

Placard Ice Detection Override Knob "ICE DET 1 (or 2) INOP".

OPERATIONAL PROCEDURES

Set the Ice Detection Override Knob to ALL position at the first visible or anticipated icing condition.

NOTE: - Icing conditions may exist inflight when Total Air Temperature (TAT) is 50°F or below and visible moisture in any form is presented (such as clouds, fog with visibility of one mile or less, rain, snow, sleet and ice crystals).

- For ice protection test A or B, as described on Airplane Operations Manual (AOM) section 1-02-79, the messages ICE DET 1 FAIL, ICE DET 2 FAIL and ICE DETECTORS FAIL may be present.

MAINTENANCE PROCEDURES

None.



MINIMUM EQUIPMENT LIST

EMBRAER 145LR

30-81-01 CLEAR ICE DETECTOR SYSTEM

Placard Clear Ice Detector Control Panel "CLEAR ICE DETECT SYS INOP" or placard Clear Ice Indication Lights "INOP".

OPERATIONAL PROCEDURES

CLR/I INOP 1 (2) EICAS messages check:

Perform the following test before engines start:

Ice Detection Override Knob.....AUTO

Ice Detection Test Knob1

Test knob must be held at least 10 seconds in this position.

Check that CLR/I INOP 1 and CLR/I INOP 2 caution messages are displayed on the EICAS.

Upper wing surface check:

A physical (hands-on) check must be done on the upper wing surface to ensure that there is no clear ice built up on the wing.

The check may be accomplished by either the maintenance personnel or the flight crew.

This inspection must be accomplished after the airplane is refueled and as near the departure as possible.

Perform the check as follows:

- The check must be performed on the upper surface of the wing, close to the wing-to-fuselage junction, in the region where the clear ice detector is installed.
- Position a ladder close to the wing leading edge. Check for the presence of ice by feeling the upper wing surface along and aft the front spar.
- Check the wing surface in the area over the clear-ice sensor and on the anti-slip stripes. The sharp parts of the granules in the stripes and the clear-ice sensor screw heads must be touched. They have a consistent rough texture. The anti-slip stripes and the Exit direction arrow may be used as visual reference as well.
- If clear ice is found, de-ice the airplane.

MAINTENANCE PROCEDURES

None.



MINIMUM EQUIPMENT LIST

EMBRAER 145LR

ATA CHAPTER 31 INDICATING/RECORDING SYSTEMS

31-21-01 CLOCKS

Placard affected Clock "INOP".

OPERATIONAL PROCEDURES

None.

MAINTENANCE PROCEDURES

None.

31-30-01 FLIGHT DATA RECORDER (FDR) SYSTEM

Placard near Clock's Multiple Selector "FDR INOP".

OPERATIONAL PROCEDURES

None.

MAINTENANCE PROCEDURES

None.

31-42-02 INTEGRATED COMPUTER CONFIGURATION MODULES (IM-600)

OPERATIONAL PROCEDURES

None.

MAINTENANCE PROCEDURES

None.



MINIMUM EQUIPMENT LIST

EMBRAER 145LR

31-51-00 AURAL WARNING UNIT

Report to the maintenance personnel.

OPERATIONAL PROCEDURES

None.

MAINTENANCE PROCEDURES

None.

31-51-02 MASTER WARNING LIGHTS/BUTTONS

Placard associated Light "LIGHT INOP" or "ALARM CANCEL INOP".

OPERATIONAL PROCEDURES

None.

MAINTENANCE PROCEDURES

None.

31-51-03 MASTER CAUTION LIGHTS/BUTTONS

Placard associated Light "LIGHT INOP" or "ALARM CANCEL INOP".

OPERATIONAL PROCEDURES

None.

MAINTENANCE PROCEDURES

None.



MINIMUM EQUIPMENT LIST

EMBRAER 145LR

ATA CHAPTER 32 LANDING GEAR

32-33-02 LANDING GEAR CONTROL LEVER LATCH SYSTEM

Placard Landing Gear Control Box "LATCH SYSTEM INOP".

OPERATIONAL PROCEDURES

After takeoff, use the Downlock Release button to actuate the Landing Gear Lever to UP.

MAINTENANCE PROCEDURES

NOTE: If the operational procedure was accomplished previously during flight, the override mechanism check does not need to be accomplished.

Override Mechanism check:

- Install safety pins on the three LG legs.
- Pull the overhead panel landing gear circuit breakers A30 "CMD" and E21 "DOOR CMD".
- Try to move the landing gear lever up. The landing gear lever shall be latched in the down position.
- Press the DOWN LOCK REL button and try to move the landing gear lever to UP. The lever should move to UP position.
- Return the LG control lever to Down position.
- Restore the airplane to normal condition.

NOTE: Visually check the landing gear shock absorbers for condition and leakage.



MINIMUM EQUIPMENT LIST

EMBRAER 145LR

32-40-01 BRAKE TEMPERATURE INDICATIONS

Placard MFD Bezel "BRAKE XX IND INOP" or "BRAKE INDICATIONS INOP".

OPERATIONAL PROCEDURES

See Quick Turn Around Weight Chart on AOM Section 1-04-30 - Performance.

MAINTENANCE PROCEDURES

In order to deactivate each affected Brake Temperature Sensor independently, follow the steps below:

- Pull the affected Brake Temperature Sensor circuit breaker and attach a DO-NOT-CLOSE tag to it:

TEMPERATURE SENSOR	CIRCUIT BREAKER
RH and LH Inboard	E19
RH and LH Outboard	E16

- Open the access panel 193AL (For EMB-145XR, 197DR and 197CL). Refer to the AMM 06-41-01/101.
- Disconnect the electrical connector associated to the failed Brake Temperature Sensor:

TEMPERATURE SENSOR	LH OUTBD	LH INBD	RH INBD	RH OUTBD
CONNECTOR	P1075	P1077	P1076	P1078

- Secure the harness associated with the disconnected connector with an appropriate tie-wrap in order to prevent it from moving freely within the fairing area.
- Install a cap (P/N MS90376-16Y or P/N NAS820-16A) in the electrical connector. Lock wire can be used to hold the cap in its place, if there is no confidence that it will be held during the airplane operation.
- Install a cap (P/N MS90376-12RB or P/N NAS831-12C) in the affected Brake Temperature Signal Conditioner.

Push back in the affected Brake Temperature Sensor circuit breaker (E16 or E19) and remove the DO-NOT-CLOSE tag from it.

NOTE: If two or more Brake Temperature Sensors are disconnected, see Quick Turn Around Weight Chart on AOM Section 1-04-30

- Performance.

In order to deactivate two or all Brake Temperature Sensors, pull and collar the affected sensor circuit breaker:

- May be flight crewmember accomplished. Pull the affected Brake Temperature Sensor circuit breaker and attach a DO-NOT-CLOSE tag to it:

TEMPERATURE SENSOR	CIRCUIT BREAKER
RH and LH Inboard	E19
RH and LH Outboard	E16



MINIMUM EQUIPMENT LIST

EMBRAER 145LR

32-41-08 BRAKE PRESSURE TRANSDUCERS

Register as appropriate for maintenance actions.

OPERATIONAL PROCEDURES

None.

MAINTENANCE PROCEDURES

Brake Pressure Transducer deactivation:

- For brake pressure transducer access refers TASK 32-41-08-000-801-A (AMM).
- Gain access to the affected pressure transducer.
- Disconnect and stow the electrical connector.
- Make sure there is no evidence of leakage on the pressure port connection.

32-44-05 ACCUMULATOR LOW PRESSURE SWITCH

Placard on EICAS Bezel "EMRG BR LO PRES MESSAGE INOP".

OPERATIONAL PROCEDURES

None.

MAINTENANCE PROCEDURES

Perform TASK 32-44-05-040-801-A (AMM) for Emergency/Parking Brake Accumulator Charge check.



MINIMUM EQUIPMENT LIST

EMBRAER 145LR

32-44-07 BRAKE ON LIGHTS

Placard affected Light "INOP".

OPERATIONAL PROCEDURES

None.

MAINTENANCE PROCEDURES

May be flight crewmember accomplished.

Parking Brake System check:

- Shut engines down and chock the airplane.
- Use APU or GPU as electrical power supply.
- Set both Thrust Levers at IDLE position.
- Turn on hydraulic system 2 electric pump.

CAUTION: NEVER MOVE CONTROL SURFACES SUCH AS FLAPS AND SPOILERS WITHOUT FIRST MAKING SURE THAT THE AREA IS CLEAR.

- Set flap to position 9° and set pitch trim within the takeoff green band limits.
- Cycle Parking Brake handle, while a second person checks that the brake actuating pistons of all brake assemblies are in operation.
- Release Parking Brakes.
- Advance Thrust levers to MAX position.
- Check that the Voice Message TAKEOFF BRAKES does not sound and the EICAS message NO TAKEOFF CONFIG is not presented.
- Apply Parking Brake and check that the Voice Message TAKEOFF BRAKES sounds and the EICAS Message NO TAKEOFF CONFIG is presented.
- Retard power lever, set flap position to 0° and turn off the hydraulic pump.



MINIMUM EQUIPMENT LIST

EMBRAER 145LR

32-49-00 BRAKE ASSEMBLY WEAR INDICATOR

Placard as appropriate.

OPERATIONAL PROCEDURES

None.

MAINTENANCE PROCEDURES

Perform TASK 32-49-03-200-801A (AMM) (Brake Assembly –
Inspection) once for each flight day.

50-00 EXTERNAL STEERING DISENGAGEMENT SWITCH

Placard External Steering Disengagement Switch "INOP".

OPERATIONAL PROCEDURES

According to the MEL remarks.

MAINTENANCE PROCEDURES

None.



MINIMUM EQUIPMENT LIST

EMBRAER 145LR

32-50-02 CONTROL WHEEL STEERING DISENGAGE BUTTONS

Placard on the pilot's console near the steering handle "PILOT FLYING'S CONTROL WHEEL STEERING DISENGAGE BUTTON INOP".

OPERATIONAL PROCEDURES

None.

MAINTENANCE PROCEDURES

May be flight crewmember accomplished.

Pilot Not Flying's Control Wheel Steering Disengage Button check:

- Perform SUBTASK 32-50-00-841-001-A00 (AMM) for airplane preparation.
- Press the pilot steering disengage button (STEER DISC) on the control wheel.
- Check STEER INOP caution message comes into view.
- Move the pedals from full right to full left and check RUDDER movement associated with no steering command. Make sure that the wheels do not move when the pedal is operated.
- Press the steering handle to reconnect the steering.
- Check STEER INOP caution message goes out of view.

32-60-00 LANDING GEAR PROXIMITY SWITCHES

Register as appropriate for maintenance actions.

OPERATIONAL PROCEDURES

None.

MAINTENANCE PROCEDURES

Proximity Switch check:

To check the proximity switch refer to TASK 32-63-05-700-801-A (AMM).



MINIMUM EQUIPMENT LIST

EMBRAER 145LR

ATA CHAPTER 33 LIGHTS

33-10-00 COCKPIT / FLIGHT DECK / FLIGHT COMPARTMENT AND INSTRUMENT LIGHTING SYSTEMS

Placard associated Light or Switch "INOP".

OPERATIONAL PROCEDURES

None.

MAINTENANCE PROCEDURES

None.

33-20-00 CABIN INTERIOR ILLUMINATION SYSTEM

Placard the Cabin Lighting Control Buttons, at the Attendant's Panel "INOP - DO NOT TURN ON".

OPERATIONAL PROCEDURES

According to the MEL remarks.

MAINTENANCE PROCEDURES

May be flight Crewmember accomplished. The overhead ceiling and sidewall lighting may contain inoperative lights not to exceed more than 10% of the total quantity, and no more than two adjacent lamps in the longitudinal or lateral direction may be inoperative. Adjacent lamps are those next to or diagonally opposing lamps. The figure below represents possible scenarios with three adjacent rows of lighting. Other scenarios are possible and the figure is for guidance only. Inoperative lamps bulbs are marked with "X". Each column represents a single overhead bulb. All inoperative lamps must be clear of galley, cabinets and life-raft storage areas.

ACCEPTABLE

	X	X
	X	X

		X
		X
	X	

	X	
		X

UNACCEPTABLE

X		
	X	
X		

	X	
	X	
X		

X	X	
	X	



MINIMUM EQUIPMENT LIST

EMBRAER 145LR

33-21-02 COCKPIT STERILE LIGHT

Placard Sterile Light Button "INOP".

OPERATIONAL PROCEDURES

Notify cabin attendant that sterile light is inoperative and use the service interphone system to advise when the cockpit is to be shut out.

MAINTENANCE PROCEDURES

None.

33-23-00 PASSENGER SIGNS

Placard the seats affected by the inoperative signs "DO NOT OCCUPY".

OPERATIONAL PROCEDURES

Prior to each flight the Captain must verify that the Passenger Address system operates normally and the Flight Attendant is briefed that this system must be used to notify the Flight Attendant and passengers when seats belts must be used, and smoking is prohibited.

MAINTENANCE PROCEDURES

May be flight crewmember accomplished. Verify that NO SMOKING/FASTEN SEAT BELT sign is readily available for affected seat. If the sign is not readily available, block seat(s) and placard "DO NOT OCCUPY".

33-26-00 COURTESY AND STAIRS LIGHTING SYSTEM

Placard Courtesy Lights Panel "INOP".

OPERATIONAL PROCEDURES

None.

MAINTENANCE PROCEDURES

None.



MINIMUM EQUIPMENT LIST

EMBRAER 145LR

33-30-00 COMPARTMENT LIGHTS (NOSE, TAIL, ETC)

Placard associated Light "INOP".

OPERATIONAL PROCEDURES

None.

MAINTENANCE PROCEDURES

None.

33-41-00 LANDING LIGHTS

Placard affected Landing Light Switch "INOP".

OPERATIONAL PROCEDURES

Flight crew to extinguish light manually after gear retraction.

MAINTENANCE PROCEDURES

None.

33-42-00 TAXI LIGHT

Placard Taxi Lights Switch "ONE or BOTH LT INOP".

OPERATIONAL PROCEDURES

Flight crew to extinguish light manually after gear retraction.

MAINTENANCE PROCEDURES

None.

33-43-00 NAVIGATION LIGHTS

In case of both systems failure, placard Navigation Light Switch "INOP".

OPERATIONAL PROCEDURES

None.

MAINTENANCE PROCEDURES

Wingtip Lights (Green & Red):

May be flight crewmember accomplished. Set the NAV LIGHT switch, on the maintenance panel (behind the pilot's seat), to the NORM or STBY position to select the system which is operative (See Figure).

White Lights (only applicable to airplanes equipped with Four

White Navigation Lights):

May be flight crewmember accomplished. Set the NAV LIGHT switch, on the aft ramp hail panel (See Figure), to the NORM or STBY position, in case one or both of the tail navigation lights in use become(s) inoperative.

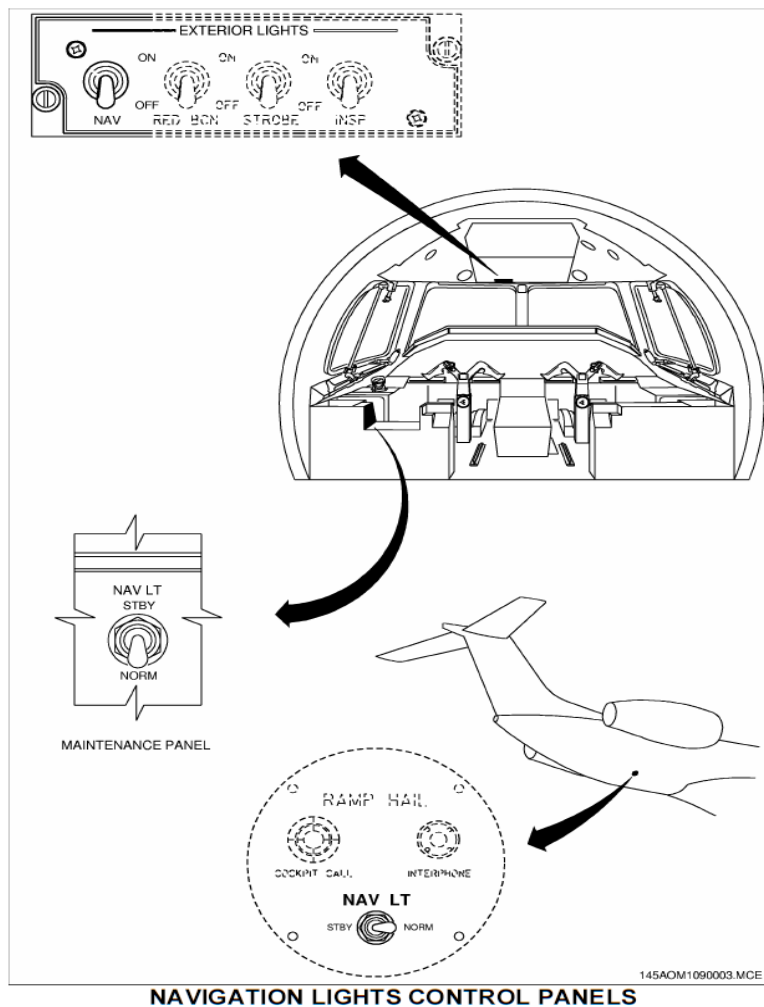



MINIMUM EQUIPMENT LIST

EMBRAER 145LR

33-44-00 WING INSPECTION LIGHTS

Placard INSP Light Switch "INOP".

OPERATIONAL PROCEDURES

None.

MAINTENANCE PROCEDURES

None.

33-46-00 LOGO LIGHTS

Placard LOGO Light Switch "INOP".

OPERATIONAL PROCEDURES

None.

MAINTENANCE PROCEDURES

None.

33-47-03 STROBE LIGHTS

Placard STROBE Switch "INOP".

OPERATIONAL PROCEDURES

None.

MAINTENANCE PROCEDURES

None.



MINIMUM EQUIPMENT LIST

EMBRAER 145LR

33-47-05 RED BEACON LIGHTS

Placard RED BCN Light Switch "INOP".

OPERATIONAL PROCEDURES

Before Starting Engines or APU:

Strobe Switch.....AS REQUIRED

For night operation, use strobe lights as a beacon to warn the ground personnel.

Red Beacon SwitchON

Set Red Beacon Switch to ON position before engine start to turn FDR on. Check carefully if the engines area is clear before starting engines.

Note: Red Beacon system could be disabled (pull and safety the RED BEACON (H19) circuit breaker), at operators' discretion, and FDR system still operates normally.

MAINTENANCE PROCEDURES

None.

33-48-00 BAGGAGE DOOR EXTERNAL LIGHT

Placard Baggage Door External Switch "LIGHT INOP".

OPERATIONAL PROCEDURES

None.

MAINTENANCE PROCEDURES

None.

33-50-00 EMERGENCY LIGHTING SYSTEM (BATTERYPOWERED)

Placard Emergency Light Switch "SYSTEM INOP".

OPERATIONAL PROCEDURES

None.

MAINTENANCE PROCEDURES

None.



MINIMUM EQUIPMENT LIST

EMBRAER 145LR

33-50-01 PHOTOLUMINESCENT FLOOR PROXIMITY EMERGENCY ESCAPE PATH MARKING

SYSTEM

OPERATIONAL PROCEDURES

None.

MAINTENANCE PROCEDURES

None.



MINIMUM EQUIPMENT LIST

EMBRAER 145LR

ATA CHAPTER 34 NAVIGATION

34-22-01 MAIN PANEL DISPLAYS

Placard the affected Display "INOP".

OPERATIONAL PROCEDURES

None.

MAINTENANCE PROCEDURES

If the EICAS display or either the flying pilot MFD or PFD display becomes inoperative, exchange its entire Display Unit with non-flying pilot MFD Display Unit and pull and safety affected Display Unit CB.

Perform TASK 34-22-01-000-801-A (AMM) for Display Unit removal and TASK 34-22-01-400-801-A (AMM) for installation.

NOTE: The flying pilot PFD and MFD must be operative.

34-22-02 TAT INDICATIONS

Placard MFD Bezel "TAT INOP".

OPERATIONAL PROCEDURES

None.

MAINTENANCE PROCEDURES

None.

34-22-03 SAT INDICATIONS

Placard MFD Bezel "SAT INOP".

OPERATIONAL PROCEDURES

None.

MAINTENANCE PROCEDURES

None.



MINIMUM EQUIPMENT LIST

EMBRAER 145LR

34-24-01 STANDBY ATTITUDE INDICATION (ON INTEGRATED STANDBY INSTRUMENT (ISIS) OR ON DEDICATED INSTRUMENT)

Placard Standby Attitude Indicator "INOP".

OPERATIONAL PROCEDURES

None.

MAINTENANCE PROCEDURES

None.

34-25-00 HEAD-UP GUIDANCE SYSTEM (HGS)

Placard Head-Up Guidance System Control Panel (HCP) "HGS INOP".

OPERATIONAL PROCEDURES

None.

MAINTENANCE PROCEDURES

None.

34-25-01 STANDBY MAGNETIC COMPASS

Placard Standby Magnetic Compass "INOP".

OPERATIONAL PROCEDURES

As required to meet the MEL remarks.

MAINTENANCE PROCEDURES

None.



MINIMUM EQUIPMENT LIST

EMBRAER 145LR

34-31-00 RADIO ALTIMETER SYSTEM

Placard in Clear View of the Pilots or PFD Bezel "RA* or RA 1 or RA 2 or RA 1 AND RA 2 INOP".

OPERATIONAL PROCEDURES

Equipment affected by Radio Altimeter deactivation:

Pre-Mod SB145-34-0083:

- RA* or RA 1 circuit breaker pulled:
- GPWS/EGPWS inoperative.
- WINDSHEAR inoperative.
- TCAS inoperative (For airplanes equipped with dual RA, the TCAS will be inoperative only if RA 1 and RA 2 are lost simultaneously).
- RA 2 circuit breaker pulled:
- None.

Pre-Mod SB145-34-0083:

- RA* or RA 1 or RA 2 circuit breaker pulled:
- GPWS/EGPWS inoperative.
- WINDSHEAR inoperative.
- TCAS inoperative (For airplanes equipped with dual RA, the TCAS will be inoperative only if RA 1 and RA 2 are lost simultaneously).

When all radar altimeters are deactivated the aural warning "LANDING GEAR" uses the radar altimeter to determine if airplane intends to land. Once landing gear position is confirmed, press the LG WRN Cutout Button to inhibit the warning and proceed with standard operating procedures.



MINIMUM EQUIPMENT LIST

EMBRAER 145LR

MAINTENANCE PROCEDURES

May be flight crewmember accomplished.

Radio Altimeter deactivated:

Pull and safety affected Radio Altimeter circuit breaker:

RADIO ALTIMETER	CIRCUIT BREAKER
RA*	D14
RA 1	D14
RA 2	D21

* Applicable for airplanes equipped with only one Radio Altimeter.

34-31-01 ALTITUDE ALERTER FUNCTION

Placard on PFD Bezel "ALTITUDE ALERT INOP".

OPERATIONAL PROCEDURES

None.

NOTE: Normal altitude call out and visual alerts (change in colors provided above the altitude display on both PFD's) shall be used.

MAINTENANCE PROCEDURES

None.

34-31-02 ALTITUDE PRESELECT FUNCTION

Placard adjacent to ASEL knob on Flight Guidance Controller "ASEL INOP".

OPERATIONAL PROCEDURES

General Information:

- With altitude preselect function inoperative, the altitude preselect display on PFD may present dashes, zero or a fixed altitude value.
- Pilots should use the Altitude Hold mode to capture the desired altitude during climb and descent operations. Normal altitude callout procedure should be used.
- Flight Level Change mode must not be used and should be considered inoperative.
- Altitude alerter annunciation or altitude preselected information must be disregarded by the crewmembers.



MINIMUM EQUIPMENT LIST

EMBRAER 145LR

- RVSM operation is not allowed.

- Go-Around Buttons must not be used and should be considered inoperative.

NOTE: - If dashes are presented on the altitude preselect display on PFD, it will be understood as zero-feet altitude by the Flight Director.

- Pilots must be warned that, if a fixed altitude value is presented on the altitude preselect display on the PFD, the airplane may capture this altitude when reaching it.

Altitude Hold Mode check:

With airplane on the ground and energized:

Flight Director ON

HDG mode..... SELECT

Check HDG and PIT label annunciated on the PFD.

SPD mode SELECT

Check command bar moving on the PFD.

ALT mode SELECT

Check command bar capturing present altitude and the ALT green label presented on the PFD.

Takeoff procedure:

Since Go-Around buttons cannot be used, pilots must perform the Takeoff Submode manually using the Touch Control Steering Button (TCS).

Selecting just a lateral mode (HDG or NAV) will activate the basic vertical mode (PIT). At rotation, keep the TCS button pressed to command a pitch attitude of 14° (for flaps at 9°), 13° (for flaps at 18°), or 12° (for flaps at 22°). Once the Pitch value is reached, the TCS button must be released and the Flight Director will maintain the set pitch until a new vertical mode is selected.

Go-Around procedure:

During Go-Around procedure autopilot must be disengaged and goaround

buttons must not be used. Flight Director must be reverted to basic mode (ROL and PIT) and pilots should perform the Go-Around mode manually using the Touch Control Steering Button (TCS).

While keeping the TCS button pressed, pilots should command a pitch attitude to allow a climbing turn with airspeed around 1.23 Vs. Once a positive rate of climb has been achieved, pilots should set a pitch of 10° nose up and release the TCS button. This constant pitch attitude must be maintained for at least 20 seconds. After that, the IAS Speed Hold mode must be selected following the go-around speed preselect on the airspeed bug with limitation at 1.23 Vs.



MINIMUM EQUIPMENT LIST

EMBRAER 145LR

MAINTENANCE PROCEDURES

None.

34-32-00 VOR/ILS SYSTEMS

Placard in Clear View of the Pilots or PFD Bezel "VOR/ILS INOP", "ILS INOP" or "MARKER BEACON INOP".

OPERATIONAL PROCEDURES

None.

MAINTENANCE PROCEDURES

None.



MINIMUM EQUIPMENT LIST

EMBRAER 145LR

34-41-00 ENHANCED GROUND PROXIMITY WARNING SYSTEM (EGPWS)

Placard GPWS Lights "GPWS INOP".

OPERATIONAL PROCEDURES

- During the Take Off and initial rise, avoid sinking, since you will not have the alert "don't sink".
- Verify and respect the MCA or the gradient of ascent specified for an output coded by instruments, as appropriate.
- The corresponding MSA should be verified, both at the airport of departure and the airport of landing.
- Verify at all times the MEA and the GRID MORA along the route to be flown.
- The different altitudes in stepped descents will be respected during an instrument approach, both precision and non-precision.
- During the final approach, respect the concept of stabilized approach, avoid sinking greater than 1200 feet per minute, since you will not have the alert "SINK RATE".

For more reference check the Quick Reference Handbook section 14 "Warning system" page.EAP-14-6 "GPWS INOPERATIVE", Standard Operation Manual Section 3-35-10 page.27 "EGPWS WARNING CORRECTIVE MANEUVER", Section 2-83 page 1, Section 3-5-10 page. 6 "WINSHEAR" and Section 3-40 page 1 "LANDING".

NOTE: The Principal Operations Inspector (POI) shall ensure an operator's alternate procedures are comprehensive and appropriate for dispatch with Windshear modes or functions of TAWS inoperative. An operator's alternate procedures and preflight briefings must include and emphasize:

- Use of established procedures to assess and minimize the probability of encountering windshear during takeoff/departure and approach/landing.
- Use of established procedures (windshear escape/recovery maneuvers) to minimize the effects of unexpected windshear encounter during takeoff/departure and approach/landing.

MAINTENANCE PROCEDURES

None.



MINIMUM EQUIPMENT LIST

EMBRAER 145LR

34-41-02 STEEP APPROACH FUNCTION

Placard PFD Bezel "STEEP APPROACH INOP".

OPERATIONAL PROCEDURES

None.

MAINTENANCE PROCEDURES

Steep Approach deactivation:

May be flight crewmember accomplished. Pull and safety the STEEP APPROACH (D1) circuit breaker on the Circuit Breaker panel.

NOTE: Some airplanes may present a different circuit breaker positioning configuration. Specific configuration may be found in the Aircraft Maintenance Manual (AMM).

34-42-00 WEATHER RADAR SYSTEM

Placard Weather Radar Control Panel "INOP" or "STABILIZATION INOP".

OPERATIONAL PROCEDURES

None.

MAINTENANCE PROCEDURES

Perform TASK 34-42-01-040-801-A (AMM) for antenna sweep check.

34-43-00 TRAFFIC ALERT AND COLLISION AVOIDANCE SYSTEM

Placard RMU or MFD Bezel Display or Panel "TCAS INOP".

OPERATIONAL PROCEDURES

RA or TA visual and audio function check:

Perform TCAS System test to ensure that RA or TA display and audio functions are operative.

Additionally:

For sunrise to sunset operations and night time operations at airports with radar coverage:

- Operations are permitted following the sterile cockpit concept procedure and raising the traffic surveillance and ATC indications,
- Maintain high level of traffic surveillance and ATC indications during enroute and approach procedures.

For night time operations at airports without radar coverage:

- All operations for these conditions are prohibited.

MAINTENANCE PROCEDURES

Traffic Alert and Collision Avoidance System deactivation:

May be flight crewmember accomplished. Pull and safety affected TCAS circuit breaker:

MODEL	CIRCUIT BREAKER
TCAS I	J6
TCAS II	J6
TCAS 2000	D3

Note: It is not recommended setting the ATC ON because this mode does not transmit the altitude reporting.

34-51-00 DISTANCE MEASURING EQUIPMENT (DME)

SYSTEMS

Placard PFD Bezel "DME INOP".

OPERATIONAL PROCEDURES

None.

MAINTENANCE PROCEDURES

None.



MINIMUM EQUIPMENT LIST

EMBRAER 145LR

34-52-00 ATC TRANSPONDERS AND AUTOMATIC ALTITUDE REPORTING SYSTEMS

Placard RMU Panel "XPDR INOP".

OPERATIONAL PROCEDURES

According to the MMEL remarks.

MAINTENANCE PROCEDURES

None.

34-53-00 ADF SYSTEM

Placard RMU Bezel "ADF INOP".

OPERATIONAL PROCEDURES

None.

MAINTENANCE PROCEDURES

None.

34-54-00 XM WEATHER SYSTEM

Placard Weather Radio System "INOP".

OPERATIONAL PROCEDURES

None.

MAINTENANCE PROCEDURES

None.



MINIMUM EQUIPMENT LIST

EMBRAER 145LR

34-56-00 GLOBAL POSITIONING SYSTEM

Placard GPS Panel "INOP".

OPERATIONAL PROCEDURES

According to the MEL remarks.

NOTE: In case of GPS inoperative, terrain awareness alerting and display functionality must be manually inhibited. For dual GPS configuration, terrain awareness alerting and display functionality must be inhibited when both GPS are inoperative.

MAINTENANCE PROCEDURES

None.

34-60-00 FLIGHT MANAGEMENT SYSTEM

Placard FMS Panel "INOP".

OPERATIONAL PROCEDURES

According to the MEL remarks.

MAINTENANCE PROCEDURES

None.

NOTE: - The AH-900 AHRS complete alignment requires a valid input of the airplane's present position from the FMS or through the MDF 1. The present position input through MFD 1 is possible only if the IM-600 has been properly configured (airplanes equipped with EICAS 18 and on).

- Airplanes equipped with EGPWS and operating without FMS will lose the terrain clearance floor mode. A TERRAIN INOP message will be presented on the EICAS.



MINIMUM EQUIPMENT LIST

EMBRAER 145LR

ATA CHAPTER 35 OXYGEN

35-11-00 OXYGEN PRESSURE INDICATION SYSTEMS

Placard MFD Bezel "OXY PRESS IND INOP".

OPERATIONAL PROCEDURES

Check if the gage reading, on the oxygen service panel, is at or above the minimum required for dispatch (refer to the AOM - Section 2-16 - Minimum Oxygen Pressure for Dispatch).

MAINTENANCE PROCEDURES

None.

35-11-03 OXYGEN-CYLINDER PRESSURE RELIEF DISC (GREEN DISC)

Placard as appropriate.

OPERATIONAL PROCEDURES

None.

MAINTENANCE PROCEDURES

None.

35-20-00 PASSENGER OXYGEN SYSTEM

Placard Passenger Oxygen Panel "PAX OXY DEPLOY INOP" or "PAX OXY INOP".

OPERATIONAL PROCEDURES

If automatic deployment is inoperative and it is necessary to deploy passenger oxygen masks, position the Passenger Oxygen Selector knob to MAN.

OR

According to the MEL remarks.

MAINTENANCE PROCEDURES

Perform TASK 35-20-00-700-801-A (AMM) for manual deployment system operational check.

OR

According to the MEL remarks.



MINIMUM EQUIPMENT LIST

EMBRAER 145LR

35-20-05 PASSENGER OXYGEN SYSTEM DOOR - MANUAL OPENING TOOL

OPERATIONAL PROCEDURES

According to MEL remarks.

MAINTENANCE PROCEDURES

None.



MINIMUM EQUIPMENT LIST

EMBRAER 145LR

35-30-01 PORTABLE OXYGEN UNITS (BOTTLE AND MASK)

Placard associated Bottle and Mask "INOP".

OPERATIONAL PROCEDURES

None.

MAINTENANCE PROCEDURES

May be flight crewmember accomplished.

Inoperative bottles and masks are placarded inoperative, removed from the installed location and placed out of sight so they cannot be mistaken for a functional unit.

Inoperative bottles and masks are replaced, serviced or removed at the next base maintenance facility.

35-30-03 PROTECTIVE BREATHING EQUIPMENT (PBE)

Placard on the affected equipment storage compartment "REMOVED".

OPERATIONAL PROCEDURES

None.

MAINTENANCE PROCEDURES

None.



MINIMUM EQUIPMENT LIST

EMBRAER 145LR

ATA CHAPTER 36 PNEUMATIC

36-11-05 ENGINE BLEED SYSTEMS

Placard the affected Bleed Air Button "INOP".

OPERATIONAL PROCEDURES

When the Left Engine Bleed Shutoff Valve is inoperative and the Right Engine Bleed Shutoff Valve and the APU Bleed Shutoff Valve are operating normally and supplying bleed air, flight should be conducted at or below FL 370.

When the Left Engine Bleed Shutoff Valve and the APU Bleed Shutoff Valve are inoperative and the Right Engine Bleed Shutoff Valve is operating normally and supplying bleed air, flight should be conducted at or below FL 250.

When the Right Engine Bleed Shutoff Valve is inoperative and the Left Engine Bleed Shutoff Valve is operating normally and supplying bleed air, flight should be conducted at or below FL 250.

When Both Engine Bleed Shutoff Valves are inoperative and the APU Bleed Shutoff Valve is operating normally and supplying bleed air, flight should be conducted at or below 18000 ft.

When Both Engine Bleed Shutoff Valves and the APU bleed Shutoff Valve are inoperative, flight should be conducted at or below 10000 ft. Refer to Item 21-31-03 for unpressurized configuration flight. On the ground, ambient temperature must be below ISA + 21°C.

MAINTENANCE PROCEDURES

NOTE: For MEL dispatch purposes, the Engine Bleed System is comprised of: Engine Bleed Shutoff Valve (EBV) or Pressure Regulator Shutoff Valve (P-RSOV), Fan Air Valve, Fan Air Thermostat, Pre-Cooler and Bleed Temperature Sensors, Differential Pressure Switch, High Stage Valve, High Stage Pressure Switch and Bleed Air Check Valve.

Engine Bleed Shutoff Valve secured closed:

- Gain access to the affected valve (AMM - Chapter 36).
- Disconnect, insulate and stow the electrical connector.
- Remove the locking screw from the actuator housing. It has a retaining cable.
- Turn the valve to the closed position. The locking crank has a hex head so you can put a wrench on it to turn the valve.
- Install the locking screw in the hole in the actuator housing that is nearest to the locking crank.

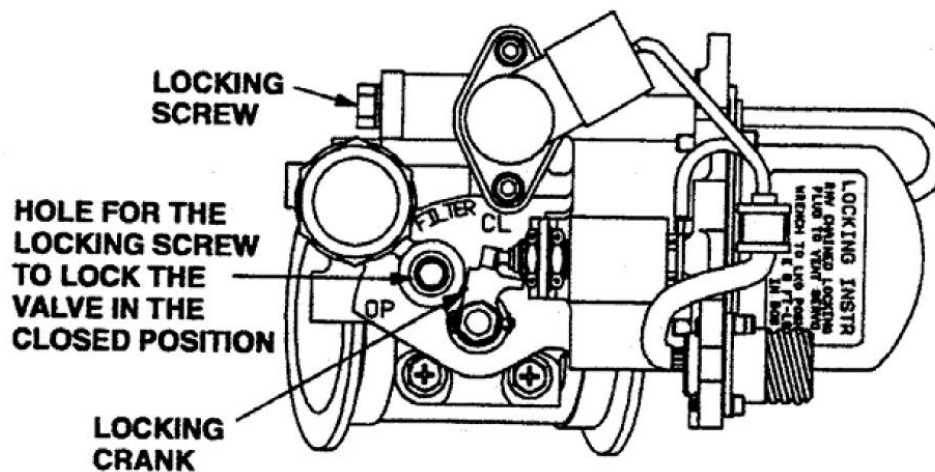
**ENGINE BLEED SHUTOFF VALVE**

Engine Bleed Pressure Regulator Shutoff Valve secured closed:

- Remove the following access panels: 414DB (LH pylon) or 424DB (RH pylon).
- Verify that the pneumatic system is de-pressurized and that the solenoid is de-energized.
- Loosen the position indicator lock screw.
- Slide the lock into the recess of the cover plate. A rotation of the screw may be necessary to center the lock in the recess of the cover plate.
- Torque the position indicator lock screw to 11 to 13 lb-in.

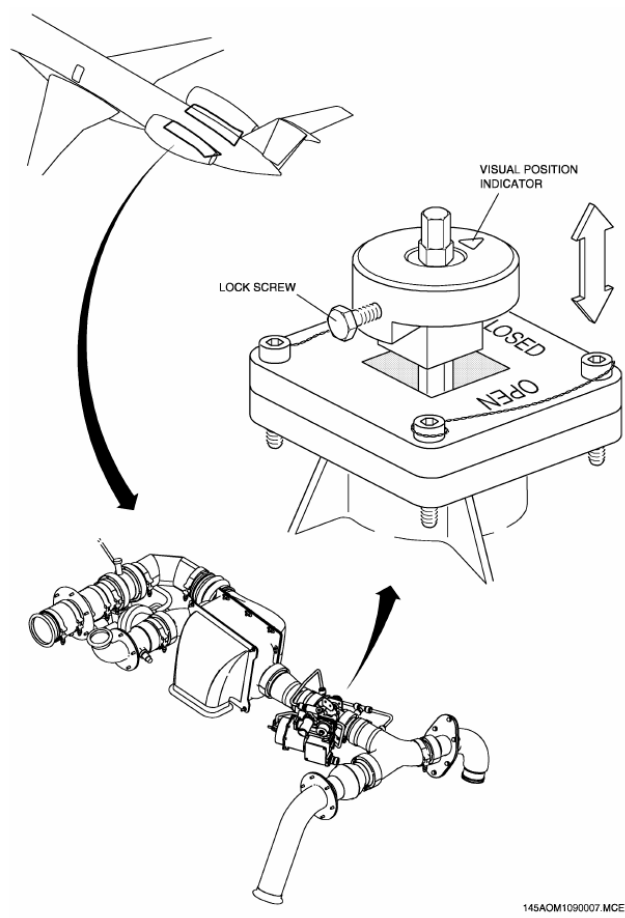
**ENGINE BLEED PRESSURE REGULATOR SHUTOFF VALVE**



MINIMUM EQUIPMENT LIST

EMBRAER 145LR

36-12-01 APU BLEED SYSTEM

Placard APU Bleed Button "INOP".

OPERATIONAL PROCEDURES

None.

NOTE: In case of APU bleed system deactivated, a ground pneumatic unit is required for engine start. Refer to item 49-00-00 (operational procedure).

MAINTENANCE PROCEDURES

APU Bleed Shutoff Valve secured closed:

Perform TASK 36-12-01-040-801-A (AMM) for APU T-62T-40 C11 or TASK 36-12-03-040-801-A (AMM) for APU T-62T-40 C14.

36-20-00 BLD APU LEAK WARNING MESSAGE

Placard EICAS Bezel "BLD APU LEAK MESSAGE INOP".

OPERATIONAL PROCEDURES

None.

MAINTENANCE PROCEDURES

None.



MINIMUM EQUIPMENT LIST

EMBRAER 145LR

ATA CHAPTER 38 WATER/WASTE

38-10-00 WATER SYSTEMS

Placard External Potable Water Service Door "DO NOT SERVICE".

Register as appropriate for maintenance actions.

OPERATIONAL PROCEDURES

None.

MAINTENANCE PROCEDURES

- Deactivate or isolate the associated inoperative components.
- If system is leaking, it must be drained. Ground service must be contact to drain system.
- If tank can not be drained, accomplish AMM TASK 38-10-05-790-801-A for the tank valve leakage test.

38-30-00 LAVATORY WASTE SYSTEMS (INCLUDING WHEELCHAIR ACCESSIBLE LAVATORIES)

Placard Lavatory Door " INOPERATIVE – DO NOT ENTER ".

Register as appropriate for maintenance actions.

OPERATIONAL PROCEDURES

- Inspections of the lavatory by crewmembers.
- Flight attendant must be briefed that the lavatory is locked and may not be used.
- Advise Ground Service Personnel **not** to service Lavatory waste system.

MAINTENANCE PROCEDURES

- Deactivate or isolate the associated inoperative components.
- If system is leaking, ground service must be contact to drain system. In case of toilet overservicing, perform AMM TASK 05-50-12-100-801-A (Cleaning Procedure) prior to next flight and AMM TASK 05-50-12-200-801-A (Complete Cleaning Procedure/Check) within next 10 consecutive days.
- May be flight crewmember accomplished: Lock lavatory door and install "LAVATORY INOPERATIVE" placard on lavatory door.



MINIMUM EQUIPMENT LIST

EMBRAER 145LR

ATA CHAPTER 45 CENTRAL MAINTENANCE COMPUTER

45-45-01 **CENTRAL MAINTENANCE COMPUTER (CMC)**

Register as appropriate for maintenance personnel actions.

OPERATIONAL PROCEDURES

None.

MAINTENANCE PROCEDURES

None.

ATA CHAPTER 49 AIRBORNE AUXILIARY POWER

49-00-00 AUXILIARY POWER UNIT (APU)

Placard APU Control Panel "INOP".

OPERATIONAL PROCEDURES

A Pneumatic Start Unit is required for engine start when APU is inoperative. Refer to TASK 20-40-03-860-801-A (AMM) to connect the Pneumatic Start Unit.

If no Pneumatic Start Unit is available, at least one engine should be kept running during turn-around (refer to AOM Section 1-12-25 Refueling with an Engine Running and Deplaning or Boarding with

One Engine Running procedures).

MAINTENANCE PROCEDURES

May be flight crewmember accomplished. Pull and safety the APU CONTROL circuit breakers, (C30) on the Circuit Breaker panel and the (E6) on the Left DC distribution box.

49-70-01 APU OIL LO PRESS CAUTION MESSAGE

Placard APU Control Panel "USE ONLY ON GROUND".

Placard EICAS Bezel "APU OIL LO PRESS MESSAGE INOP".

OPERATIONAL PROCEDURES

None.

MAINTENANCE PROCEDURES

None.

49-70-02 APU OIL HI TEMP CAUTION MESSAGE

Placard APU Control Panel "USE ONLY ON GROUND".

Placard EICAS Bezel "APU OIL HI TEMP MESSAGE INOP".

OPERATIONAL PROCEDURES

None.

MAINTENANCE PROCEDURES

None.



MINIMUM EQUIPMENT LIST

EMBRAER 145LR

49-70-03 APU FAIL CAUTION MESSAGE

Placard APU Control Panel "USE ONLY ON GROUND".

Placard EICAS Bezel "APU FAIL MESSAGE INOP".

OPERATIONAL PROCEDURES

None.

MAINTENANCE PROCEDURES

None.

49-74-01 APU HOURMETER FUNCTION

Register in the appropriate document for the necessary actions.

OPERATIONAL PROCEDURES

None.

MAINTENANCE PROCEDURES

The operator shall develop appropriate procedures according to its airplane utilization to control APU operating hours.



MINIMUM EQUIPMENT LIST

EMBRAER 145LR

ATA CHAPTER 52 DOORS

52-12-00 MAIN DOOR HYDRAULIC ACTUATION SYSTEM

Placard on Door Panel (Entrance and Exterior) "DOOR ACTUATION INOP".

OPERATIONAL PROCEDURES

None.

MAINTENANCE PROCEDURES

Damper Function checking:

Lift the door manually up to its mid closed position, and then let the door to come down. Check that door moves down slowly, with damping.

NOTE: Care should be taken to avoid that the door coming down without damping.

52-51-00 C&D AEROSPACE FLIGHT DECK SECURITY DOOR

Placard Door "INOP".

OPERATIONAL PROCEDURES

None.

MAINTENANCE PROCEDURES

None.

52-70-00 DOOR WARNING SYSTEM (DOOR POSITION INDICATION ON MFD AND EICAS)

Placard MFD and EICAS Bezel "AFFECTED DOOR WARNING IND INOP".

OPERATIONAL PROCEDURES

Carefully check all doors closed and latched before each departure.

Main and service door internal check must be done by using a flashlight to confirm that all the red marks of each door are aligned (see figures).

NOTE: This procedure requires the usage of a flashlight to help visualizing the red marks alignment precisely.



MINIMUM EQUIPMENT LIST

EMBRAER 145LR

MAINTENANCE PROCEDURES

May be flight crewmember accomplished. Carefully check all doors closed and latched before each departure. Main, service and baggage doors must be checked aligned with the fuselage and the handles must be stowed.

In case of nuisance message being triggered:

-Perform AMM TASK 52-71-01-000-801-A for forward electronic compartment access hatch, at operator's discretion.

-Perform AMM TASK 52-72-01-000-801-A for cockpit underfloor access hatch, at operator's discretion.

-Perform AMM TASK 52-73-01-000-801-A for main door, at operator's discretion.

-Perform AMM TASK 52-74-01-000-801-A for service door, t operators' discretion.

-Perform AMM TASK 52-75-01-000-801-A for emergency access hatches, at operator's discretion.

-Perform AMM TASK 52-76-01-000-801-A for cargo door, at operator's discretion.

-Perform AMM TASK 52-77-01-000-801-A for rear electronic compartment access hatch, at operator's discretion.

-Perform AMM TASK 52-78-01-000-801-A for fueling door, at operator's discretion.

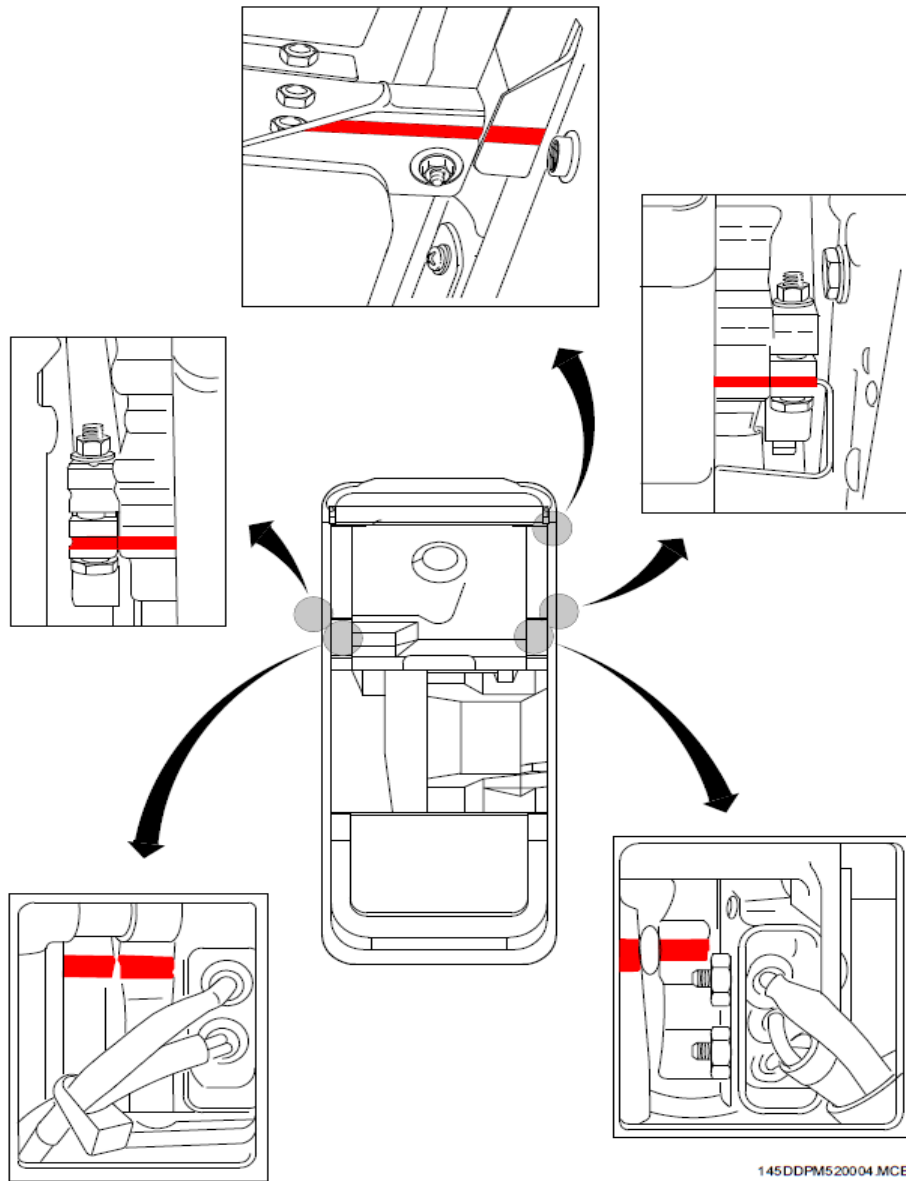

145DDPM520004.MCE

SIDE-HINGED MAIN DOOR RED MARKS

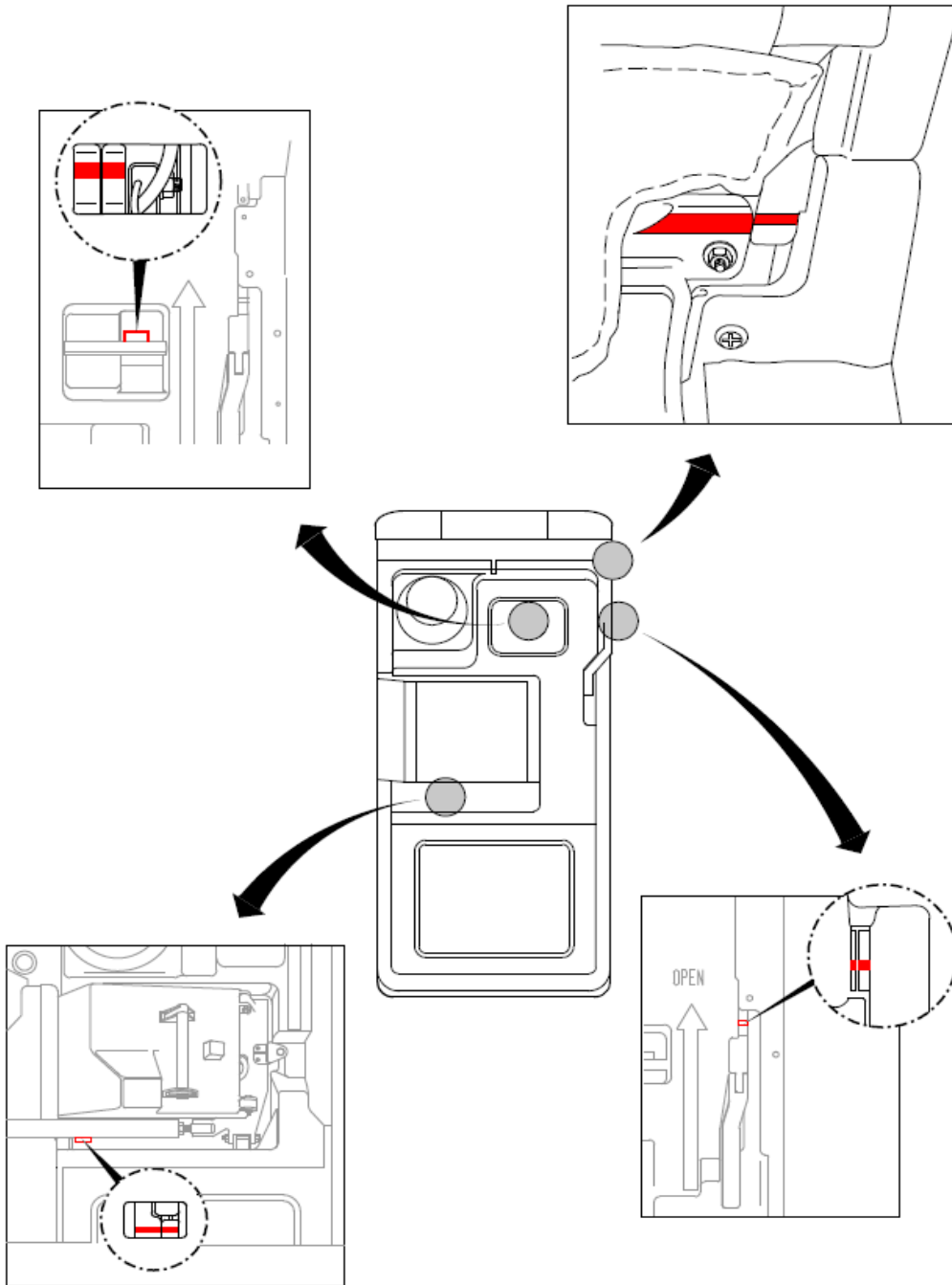

145DDPM520006.MCE

SERVICE DOOR RED MARKS



MINIMUM EQUIPMENT LIST

EMBRAER 145LR

ATA CHAPTER 73 ENGINE FUEL AND CONTROL

73-22-01 ENGINE FULL AUTHORITY DIGITAL ELECTRONIC CONTROL (FADEC) SYSTEM

Placard Power Plant Control Panel "FADEC XX DEFERRED BY MEL/TLD".

OPERATIONAL PROCEDURES

None.

MAINTENANCE PROCEDURES

None.

73-22-02 AUTOMATIC TAKEOFF THRUST CONTROL SYSTEM (ATTCS) (AIRPLANES EQUIPPED WITH A, A1/1, A1 AND A3 ENGINES ONLY)

Placard near Thrust Rating Mode Buttons "ATTCS INOP".

OPERATIONAL PROCEDURES

Select T/O-1 thrust mode using Takeoff Data Setting procedure prior to takeoff. Refer to AOM - Section 2-10.

MAINTENANCE PROCEDURES

None.

73-32-01 ENGINE FUEL TEMPERATURE SENSORS

Placard EICAS Bezel "E1 (or 2) LO TEMP MESSAGE INOP".

OPERATIONAL PROCEDURES

Ensure that icing inhibitor is added to the fuel. If an icing inhibitor has not been added, refer to MFD fuel page and ensure temperature of fuel in the tank remains above 4°C throughout the flight.

MAINTENANCE PROCEDURES

None.



MINIMUM EQUIPMENT LIST

EMBRAER 145LR

73-33-01 E1 (2) FUEL IMP BYP ADVISORY MESSAGES

Placard EICAS Bezel "E1 (or 2) FUEL IMP BYP MESSAGE INOP".

OPERATIONAL PROCEDURES

None.

MAINTENANCE PROCEDURES

NOTE: The engine fuel temperature sensors must not be dispatched under MEL 73-32-01 in case of E1 (2) FUEL IMP BYP messages inoperative.

- Energize the airplane with a DC Power Supply (TASK 20-40-01-860-801-A – AMM).
- Pull the START 1 and START 2 circuit breakers (B12 and B23 respectively) and attach DO-NOT-CLOSE tags to them.
- Open the associated engine lower cowling door (TASK 71-12-01-000-801-A – AMM).
- Use the following check procedures as a troubleshooting reference:

Visual indicators (pop-up buttons) check:

- Check that both the electrical/mechanical impending-bypass indicator and the mechanical actual-bypass indicator (See Figure) have their respective pop-up buttons not protruded.

Electrical/mechanical impending-bypass indicator (switch) check:

- Check that the resistance between pins B and C in the electrical/mechanical impending-bypass indicator is not greater than 10 ohms.
- Check that the resistance between the indicator shell and pins B and C, one at a time, is not lower than 1000 ohms.

Electrical connector (wiring) check:

- Disconnect the electrical connector from the electrical/mechanical impending-bypass indicator (See Figure) and wait at least 10 seconds.
- Check that EICAS advisory message E1 (2) FUEL IMP BYP is displayed.
- Connect the electrical connector to the electrical/mechanical impending-bypass indicator.
- Check that EICAS advisory message E1 (2) FUEL IMP BYP goes out of view.

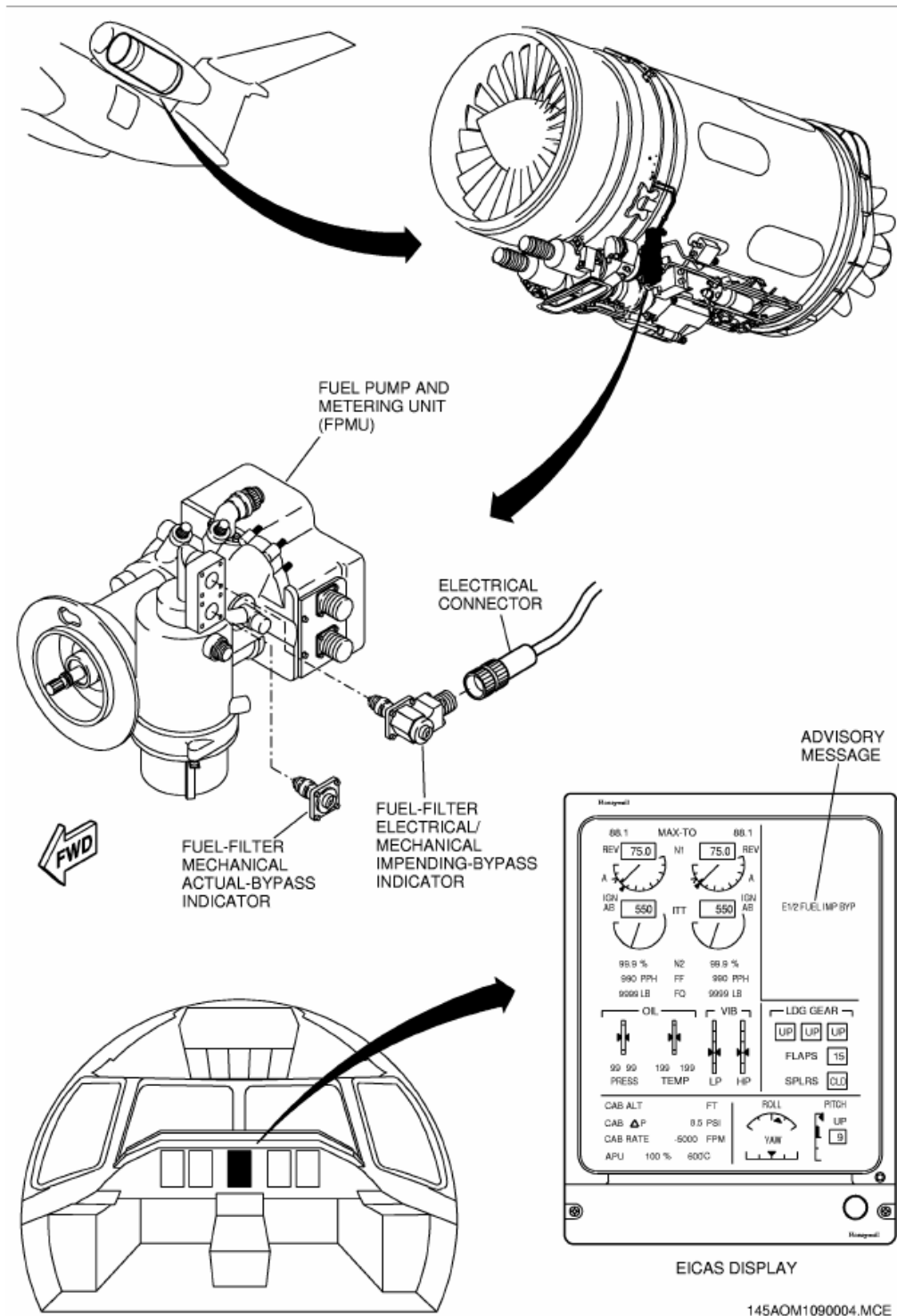

FUEL FILTER BYPASS INDICATORS



MINIMUM EQUIPMENT LIST

EMBRAER 145LR

After checking:

- Close the engine lower cowling door (TASK 71-12-01-400-801-A – AMM).
- Push in the START 1 and START 2 circuit breakers (B12 and B23 respectively) back and remove the DO-NOT-CLOSE tags from them.
- Remove the DC Power Supply (TASK 20-40-01-860-801-A – AMM).

73-33-02 FUEL FILTERS

Register as appropriate for maintenance actions.

OPERATIONAL PROCEDURES

None.

MAINTENANCE PROCEDURES

Associated fuel-filter mechanical actual-bypass indicator is checked not extended before each flight.

73-40-03 FUEL FLOW INDICATIONS

Placard EICAS Bezel "FUEL FLOW INOP".

OPERATIONAL PROCEDURES

NOTE: Abort engine start immediately when:

- Only on ground, no light-up in 20 seconds after the engine start command.

Monitor remaining engine parameters within normal values.

MAINTENANCE PROCEDURES

None.



MINIMUM EQUIPMENT LIST

EMBRAER 145LR

ATA CHAPTER 74 IGNITION

74-20-00 IGNITION SYSTEM CHANNELS

Placard Power Plant Control Panel on overhead panel, close to the Ignition Selector Knob of the affected engine "ONE CHANNEL INOP".

OPERATIONAL PROCEDURES

- Before starting the affected engine, select Ignition Selector Knob ON.
- Upon reaching 14% N2 during start, check green label IGN AB on EICAS.
- After normal engine start cycle completed, check steady engine parameters.
- Select Ignition Selector Knob AUTO (blank indication on EICAS).

MAINTENANCE PROCEDURES

None.



MINIMUM EQUIPMENT LIST

EMBRAER 145LR

ATA CHAPTER 76 ENGINE CONTROLS

76-12-00 ENGINE TAKEOFF DATA SETTING KNOB SPRING

Placard Overhead Panel "ENGINE TDS KNOB INOP".

OPERATIONAL PROCEDURES

Select TOTEMP and takeoff data through the inoperative knob, press STORE and check MFD takeoff parameters before takeoff.

MAINTENANCE PROCEDURES

None.



MINIMUM EQUIPMENT LIST

EMBRAER 145LR

ATA CHAPTER 77 ENGINE INDICATING

77-41-02 HP VIBRATION INDICATION

Placard EICAS Bezel "HP VIB INOP".

OPERATIONAL PROCEDURES

None.

MAINTENANCE PROCEDURES

None.



MINIMUM EQUIPMENT LIST

EMBRAER 145LR

ATA CHAPTER 79 ENGINE OIL

79-32-01 LOW OIL PRESSURE SWITCHES

Placard EICAS Bezel "E1 (or 2) OIL LOW PRESS MESSAGE INOP".

OPERATIONAL PROCEDURES

None.

MAINTENANCE PROCEDURES

Perform TASK 12-12-01-600-801-A (AMM) for oil quantity servicing.

79-33-01 OIL LEVEL INDICATION SYSTEMS

Placard MFD Bezel "OIL1 (or 2) IND INOP".

OPERATIONAL PROCEDURES

None.

MAINTENANCE PROCEDURES

Perform TASK 12-12-01-600-801-A (AMM) for oil quantity servicing.

79-34-01 OIL PARTICLE SENSORS

Register as appropriate for maintenance actions.

OPERATIONAL PROCEDURES

None.

MAINTENANCE PROCEDURES

Perform the visual check on the affected oil tank magnetic plug. Refer to Rolls Royce MM TASK 79-30-00-200-801.



MINIMUM EQUIPMENT LIST

EMBRAER 145LR

79-35-01 E1 (2) OIL IMP BYP MESSAGES

Register as appropriate for maintenance actions.

OPERATIONAL PROCEDURES

None.

MAINTENANCE PROCEDURES

Open the affected engine lower cowling and verify the visual indicator inside housing.

Perform TASK 45-45-00-970-801-A (AMM) for the CMC downloading with the MFD maintenance page.

79-35-02 OIL FILTERS

Register as appropriate for maintenance actions.

OPERATIONAL PROCEDURES

None.

MAINTENANCE PROCEDURES

Perform TASK 79-30-00-200-802 (ROLLS ROYCE AE3007A Series Maintenance).



MINIMUM EQUIPMENT LIST

EMBRAER 145LR

ATA CHAPTER 78 ENGINE EXHAUST

78-30-00 THRUST REVERSERS

Placard Control Pedestal "THRUST REVERSER INOP".

OPERATIONAL PROCEDURES

When operating with one thrust reverser secured stowed, the FADEC of the operative side will only command reverse thrust if the associated Thrust Lever is requesting reverse thrust and the Thrust Lever of the affected side is set to idle. [Differential braking and rudder may be required to maintain directional control.](#)

MAINTENANCE PROCEDURES

Perform TASK 78-31-01-980-801-A (AMM) for the affected thrust reverser stowage.

In case of thrust reverser hydraulic system leakage, perform TASK 78-31-01-980-803-A (AMM) before performing TASK 78-31-01-980-801-A (AMM).

78-34-00 ENG1 (2) REV DISAGREE MESSAGES

OPERATIONAL PROCEDURES

When operating with one thrust reverser secured stowed, the FADEC of the operative side will only command reverse thrust if the associated Thrust Lever is requesting reverse thrust and the Thrust Lever of the affected side is set to idle.

MAINTENANCE PROCEDURES

Perform TASK 78-31-01-980-801-A (AMM) for thrust reverser stowage.



MINIMUM EQUIPMENT LIST

EMBRAER 145LR

78-34-05 IDLE STOP (SOLENOID)

Placard Control Pedestal "THRUST REVERSER INOP".

OPERATIONAL PROCEDURES

When operating with one thrust reverser secured stowed, the FADEC of the operative side will only command reverse thrust if the associated Thrust Lever is requesting reverse thrust and the Thrust Lever of the affected side is set to idle.

NOTE: Never set thrust levers below idle in flight.

MAINTENANCE PROCEDURES

Perform TASK 78-31-01-980-801-A (AMM) for the affected thrust reverser stowage.

In case of thrust reverser hydraulic system leakage, perform TASK 78-31-01-980-803-A (AMM) before performing TASK 78-31-01-980-801-A (AMM)



MINIMUM EQUIPMENT LIST

EMBRAER 145LR

ATA CHAPTER 80 STARTING

80-00-00 ENGINE START/STOP SWITCH PROTECTION GUARDS

Placard Powerplant Control Panel "PROTECTION GUARD INOP".

OPERATIONAL PROCEDURES

None.

MAINTENANCE PROCEDURES

None.

80-10-02 STARTER CONTROL VALVES

Placard EICAS Bezel or Powerplant Control Panel "STARTER CONTROL VALVE INOP".

OPERATIONAL PROCEDURES

Manual Override Start Procedure:

- Ensure communications are in place with maintenance personnel operating the Starter Control Valve manually.
- When ready to start, perform a normal start.
- Ensure maintenance personnel are notified when engine N2 comes to the IDLE.
- Ensure ground personnel are clear after start.

MAINTENANCE PROCEDURES

Manual Override Start Procedure:

- Use the rear (ramp) interphone system for communications between persons on the ramp and in the cockpit.
- Perform TASK 80-10-02-980-801-A (AMM) to start the affected engine using Starter Control Valve Manual Override procedure.
- When the task is complete and all personnel and equipment are clear of the airplane, notify the cockpit.



MINIMUM EQUIPMENT LIST

EMBRAER 145LR

EICAS Caution Message E1(2) ATS SOV OPN check:

- Access the Starter Control Valve by performing TASK 80-10-02-980-801-A (AMM).
- Airplane..... ENERGIZE
- EICAS Override Switch (cockpit) OVRD
- Starter Control Valve..... OPEN

Tell the ground personnel to open the Starter Control Valve.

- Check Caution Message E1(2) ATS SOV OPN displayed on the EICAS.
- EICAS Override Switch..... NORM

CONFIGURATION DESVIATION LIST

ATA CHAPTER 06 DIMENSIONS AND AREAS

System & Sequence Number	ITEM	1.	2. Number installed		4. Remarks and/or exceptions
			3.	Number required for dispatch	
6 DIMENSIONS AND AREAS					
41-1	Exterior Main Door Control Panel Access Door (123AL - Figure 1)	1	0		May be missing with no penalty.
41-2	External Power Connection Access Door (113EL - Figure 1)	1	0		May be missing with no penalty.
41-3	Ground Air Conditioning Connection Access Door (191AR - Figures 3, 5)	1	0		May be missing provided maximum airspeed is limited to 250 KIAS/0.65 M, whichever is lower.
41-4	Air Conditioning Heat Exchanger Grills (191ML - Figures 2, 4) (191NR - Figures 3, 5)	2	0		May be missing provided maximum airspeed is limited to 250 KIAS/0.65 M, whichever is lower.
41-5	Pack Valve/Wing Anti-ice Valve Access Door (191KL - Figure 2) (191LR - Figure 3)	2	0		May be missing provided maximum airspeed is limited to 250 KIAS/0.65 M, whichever is lower.
41-6	Bleed Flexible Joint Access Door (195AL/CL - Figure 2) (194AR/CR - Figure 3)	4	0		May be missing provided maximum airspeed is limited to 250 KIAS/0.65 M, whichever is lower.

AOM-145/1114

REVISION 36

1-08-06	Page	Code
	1	01

System & Sequence Number	ITEM	1.	2. Number installed		4. Remarks and/or exceptions
			3.	Number required for dispatch	
6 DIMENSIONS AND AREAS					
41-7	Red Beacon Fairing (192EL - Figure 2)	1	0		May be missing provided maximum airspeed is limited to 250 KIAS/0.65 M, whichever is lower.
41-8	Hydraulic Servicing Access Door (193DL/EL/FL - Figure 2) (193GR/HR/JR - Figure 3)	6	0		May be missing provided maximum airspeed is limited to 250 KIAS/0.65 M, whichever is lower
41-9	Fuel Tank Drain Valve Access Door (192CL - Figure 2, 4) (192DR - Figure 3, 5)	2	0		May be missing provided maximum airspeed is limited to 250 KIAS/0.65 M, whichever is lower.
41-10	Fuel Wing Stub Drain Valve Access Door (192HL - Figure 4) (192JR - Figure 5) (EMB-145 LR and XR)	2	1		One may be missing with no penalty.
41-11	Drip Stick Door (192FL - Figure 4) (192GR - Figure 5) (EMB-145 LR and XR)	2	1		One may be missing with no penalty.
41-12	Pneumatic Duct Joints Access Panel (193SL/XL - Figure 4) (193YR/TR - Figure 5)	4	0		May be missing provided maximum airspeed is limited to 250 KIAS/0.65 M, whichever is lower.
41-13	Hydraulic System Service Access Door (193WL - Figure 4) (193ZR - Figure 5)	2	0		May be missing provided maximum airspeed is limited to 250 KIAS/0.65 M, whichever is lower.

1-08-06	Page 2	Code 01
---------	-----------	------------

REVISION 36

AOM-145/1114



MINIMUM EQUIPMENT LIST

EMBRAER 145LR

SYSTEM & SEQUENCE ITEM NUMBER	1.	2. NUMBER INSTALLED		4. REMARKS AND/OR EXCEPTIONS
			3. NUMBER REQUIRED FOR DISPATCH	
6 DIMENSIONS AND AREAS				
41-14 Hydraulic Oil Level Sight Glass Access Door (193UL - Figure 4) (193VR - Figure 5)	2	0		May be missing provided maximum airspeed is limited to 250 KIAS/0.65 M, whichever is lower.
41-15 Pneumatic Duct Junction Access Panel (198DL - Figure 4) (198ER - Figure 5)	2	0		May be missing provided maximum airspeed is limited to 250 KIAS/0.65 M, whichever is lower.
42-1 Pressure Fueling Panel Access Door (191BR - Figures 3, 5)	1	0		May be missing provided: a) Door microswitch is locked actuated (simulating door closed); b) Refueling, defueling and power switches are verified in the CLOSED/NORMAL position (Refer to RAMP Manual 52-78-01-DP); c) Refueling cap is locked and latched; and d) Maximum airspeed is limited to 250 KIAS/ 0.65 M, whichever is lower.
42-2 Potable Water Service Door (193MR - Figure 3)	1	0		May be missing provided maximum airspeed is limited to 250 KIAS/0.65 M, whichever is lower.
42-3 Potable Water Service Access Panel (198BR - Figure 5)	1	0		May be missing provided maximum airspeed is limited to 250 KIAS/0.65 M, whichever is lower.
42-4 Waste Service Door	1	0		May be missing with no penalty.

AOM-145/1114

REVISION 38

1-08-06	Page 3	Code 01
---------	-----------	------------

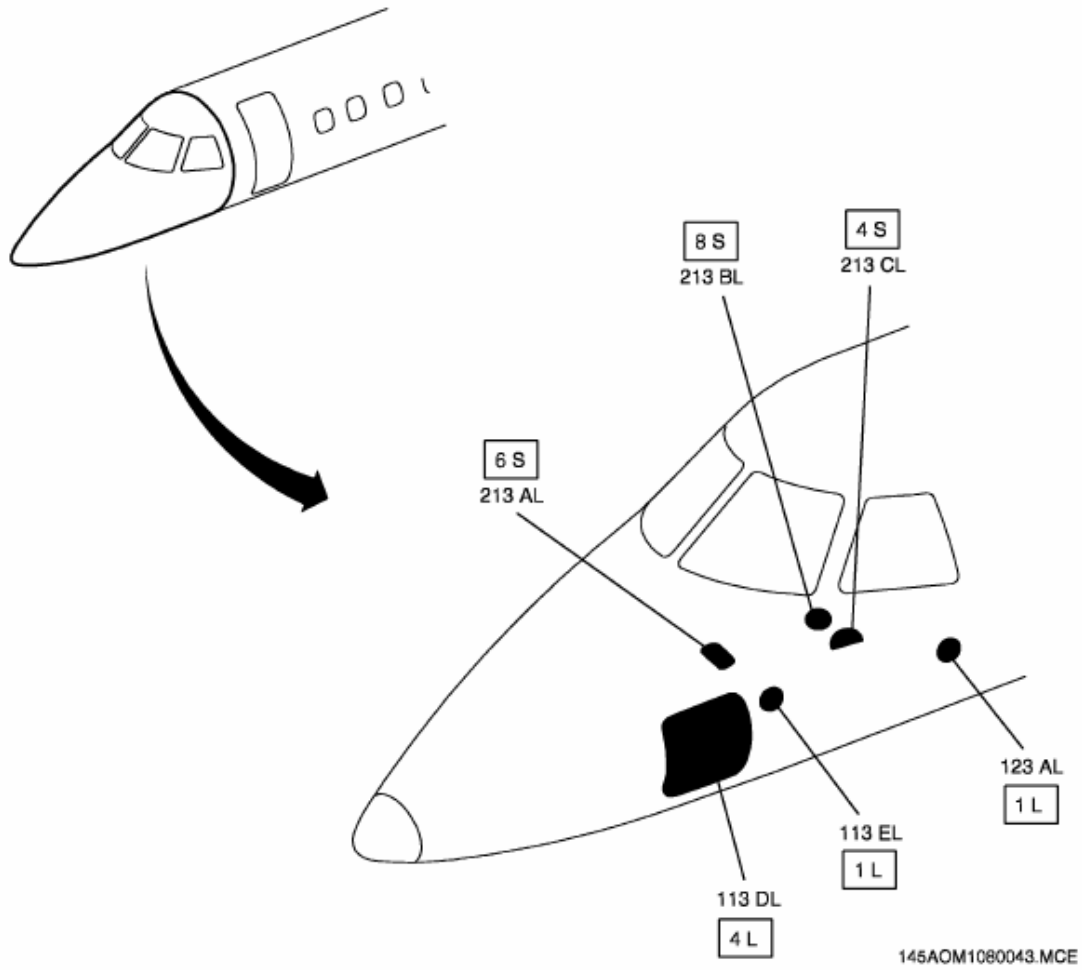
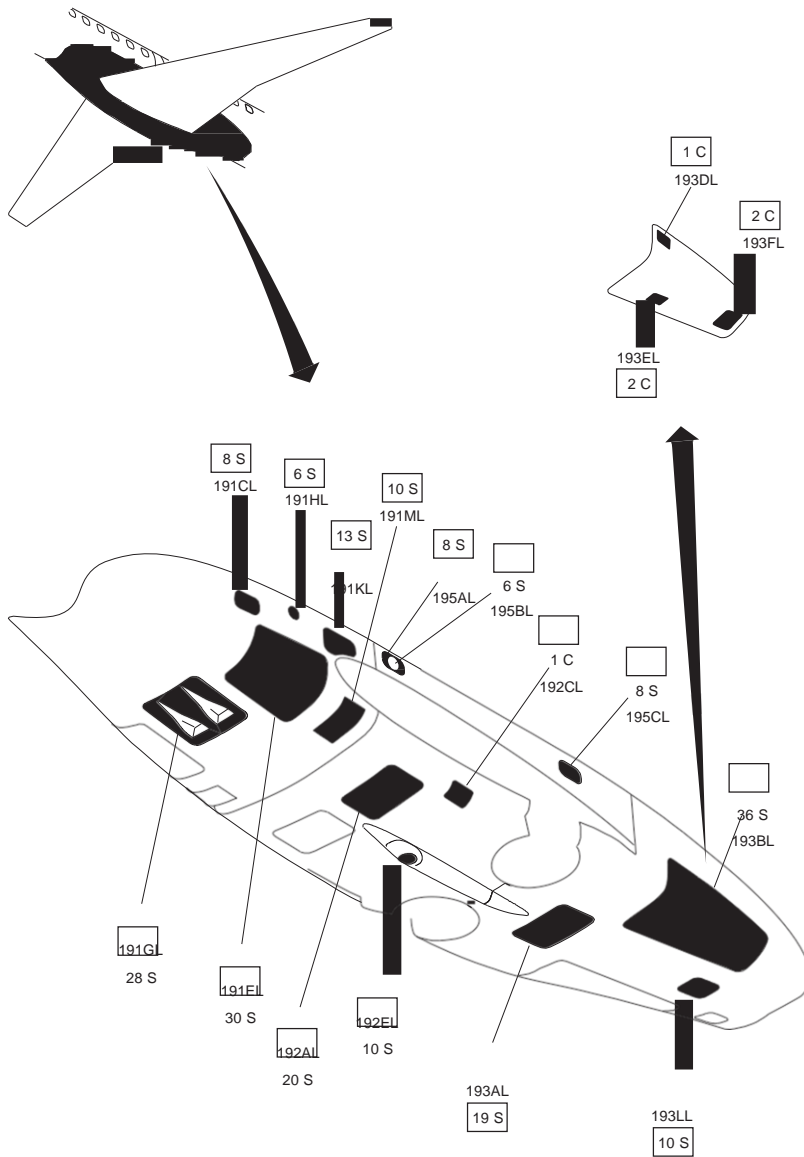

FIGURE 1

1-08-06	Page 4	Code 01
---------	-----------	------------

REVISION 36

AOM-145/1114



EM145AOM000089A.DGN

FIGURE 2 - ALL EXCEPT EMB-145XR

AOM-145/1114

REVISION 36

1-08-06	Page 5	Code 01
---------	-----------	------------

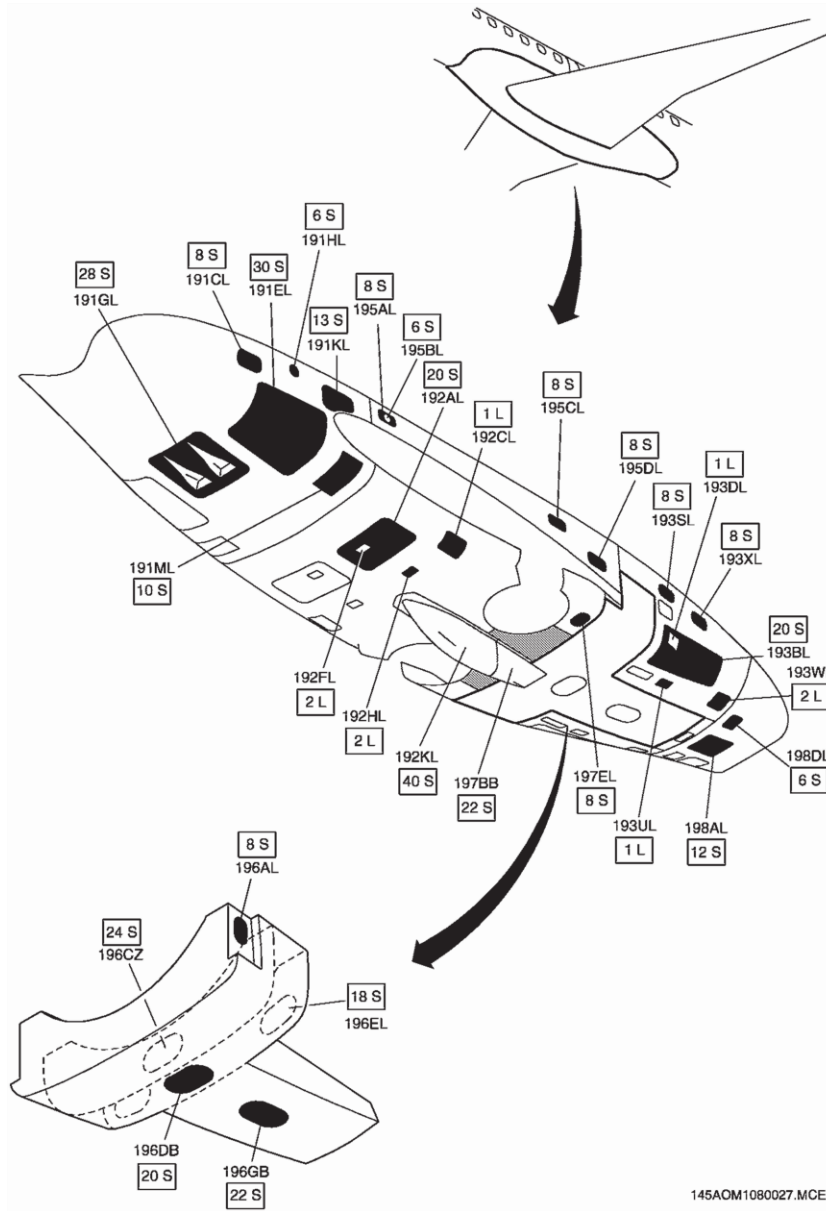

145AOM1080027.MCE

FIGURE 4 - EMB-145XR

AOM-145/1114

REVISION 36

1-08-06	Page 7	Code 01
---------	-----------	------------



MINIMUM EQUIPMENT LIST

EMBRAER 145LR

System & Sequence Number	ITEM	1.	2. Number installed		4. Remarks and/or exceptions
				3. Number required for dispatch	
6 DIMENSIONS AND AREAS					
42-5	Engine Starting Pneumatic Connection Door (272CR - Figure 6)	1	0		May be missing with no penalty.
42-6	Maintenance Interphone Connection Door (272BR - Figure 6)	1	0		May be missing with no penalty.
42-7	APU Tail Cone Attaching Bolt Access Door (313GR/DR/AL/BL - Figure 6)	4	0		May be missing with no penalty.
42-8	APU Servicing Access Door (313CL - Figure 6)	1	0		May be missing provided APU operates on the ground only. NOTE: If only APU oil temperature increases to over 135 °C (275 °F) during ground operation, the APU OIL HIGH TEMP message will be displayed on the EICAS and the APU will be automatically shut down.

AOM-145/11

REVISION 36

Page Code

1-08-06	9	01
---------	---	----

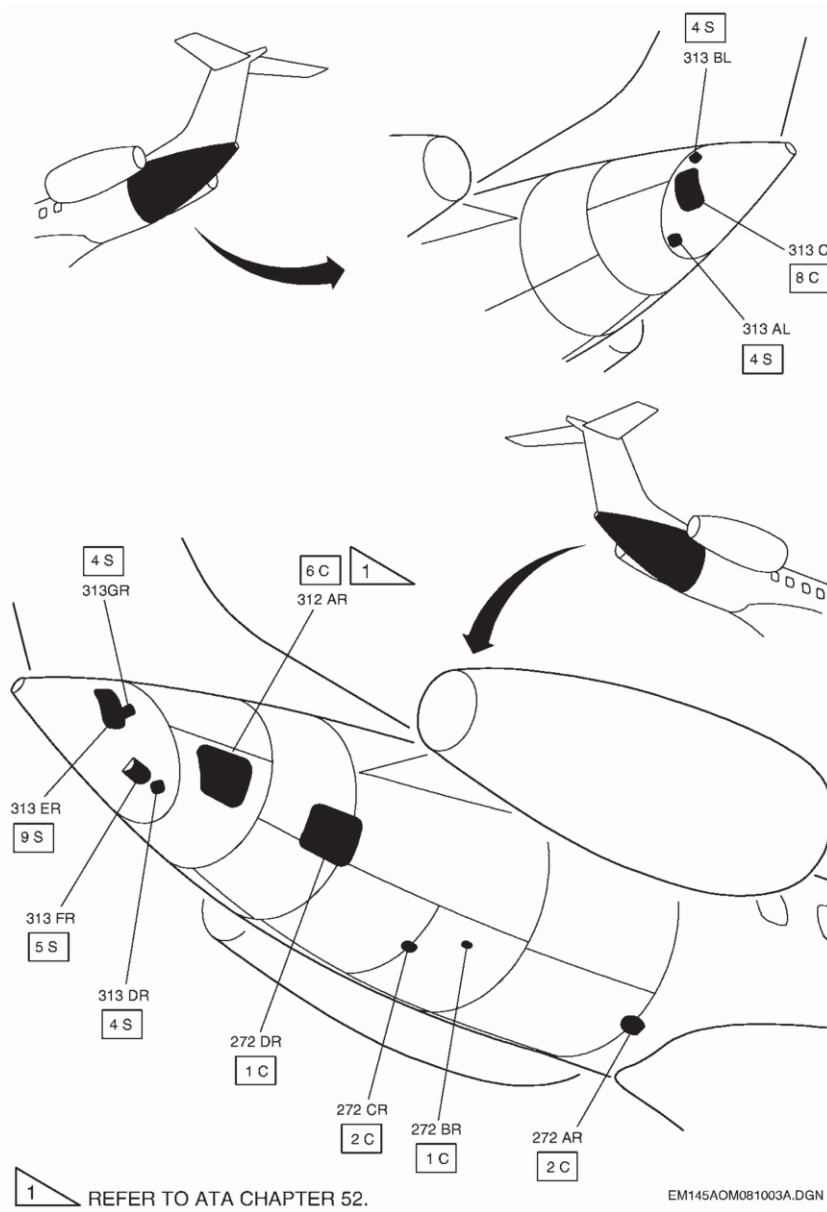

FIGURE 6

1-08-06	Page 10	Code 01
---------	------------	------------

REVISION 36

AOM-145/1114

ATA CHAPTER 23 COMMUNICATIONS

System & Sequence Number	ITEM	1.	2. Number installed		4. Remarks and/or exceptions
			3.	Number required for dispatch	
23 COMMUNICATIONS					
60-1	Static Dischargers (Figure 7) (All except EMB-145XR)	22	13		A maximum of 9 (nine) static dischargers may be missing with no penalty. At least the following dischargers are required to be installed: a) 3 (three) are installed on each wing; b) 1 (one) is installed on the rudder; c) 3 (three) are installed on each elevator.
60-2	Static Dischargers (Figure 7) (EMB-145 XR)	26	17		A maximum of 9 (nine) static dischargers may be missing with no penalty. At least the following dischargers are required to be installed: a) 4 (four) are installed on each wing; b) 1 (one) is installed on the rudder; c) 3 (three) are installed on each elevator.

AOM-145/1114

REVISION 40

1-08-23	Page 1	Code 02
---------	-----------	------------

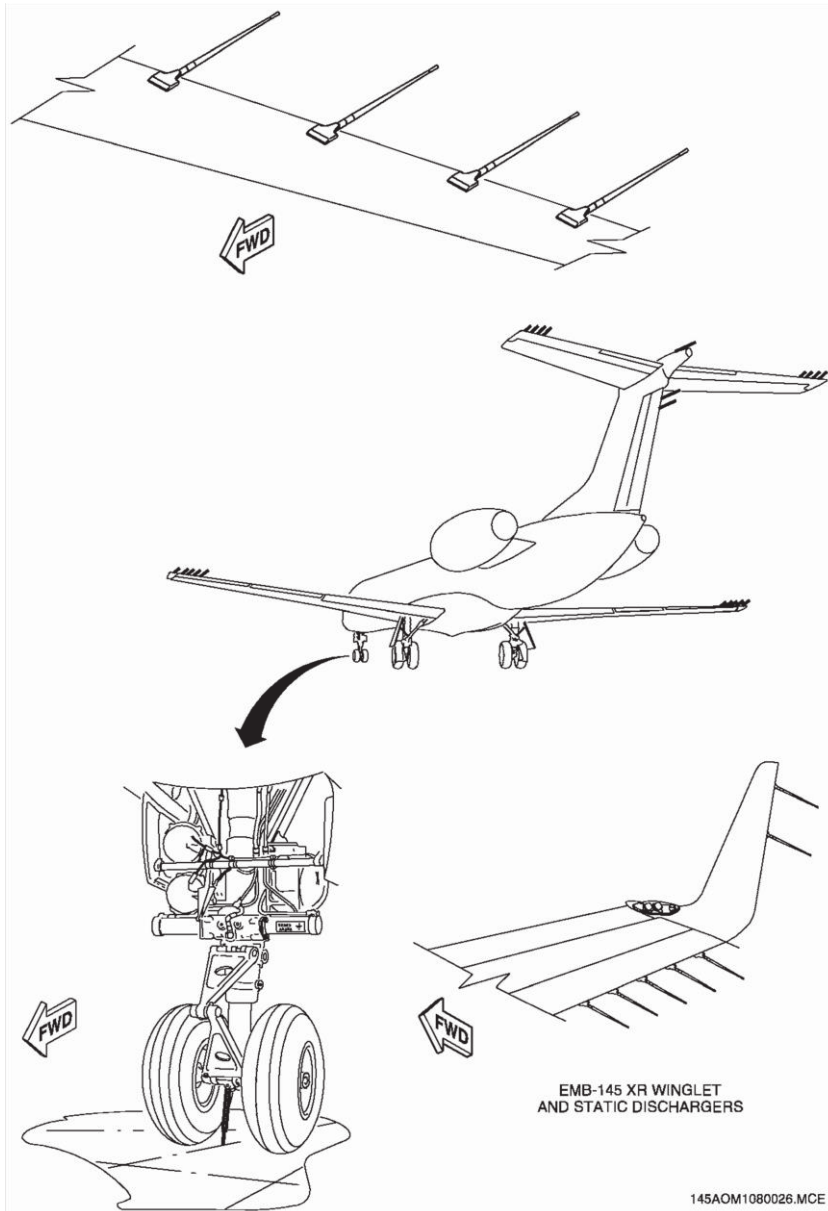

8)52%7

1-08-23	Page 2	Code 02
---------	-----------	------------

REVISION 39

AOM-145/114



MINIMUM EQUIPMENT LIST

EMBRAER 145LR

ATA CHAPTER 28 FUEL

System & Sequence ITEM Number	1.	2. Number installed		4. Remarks and/or exceptions
		3.	Number required for dispatch	
28 FUEL				
11-1 Fuel Tank Drain Access Door (192CL - Figures 2, 4) (192DR - Figures 3, 5)	2	0		May be missing provided maximum airspeed is limited to 250 KIAS /0.65 M, whichever is lower.
12-1 Vent Valves Screen Assembly (Figure 8)	2	0		May be missing with no penalty.
42-1 Direct Quantity Measuring Sticks (Figure 9)	-	0		May be missing with no penalty. Refer to MEL 28-42-01.

AOM-145/1114

REVISION 40

1-08-28	Page 1	Code 01
---------	-----------	------------

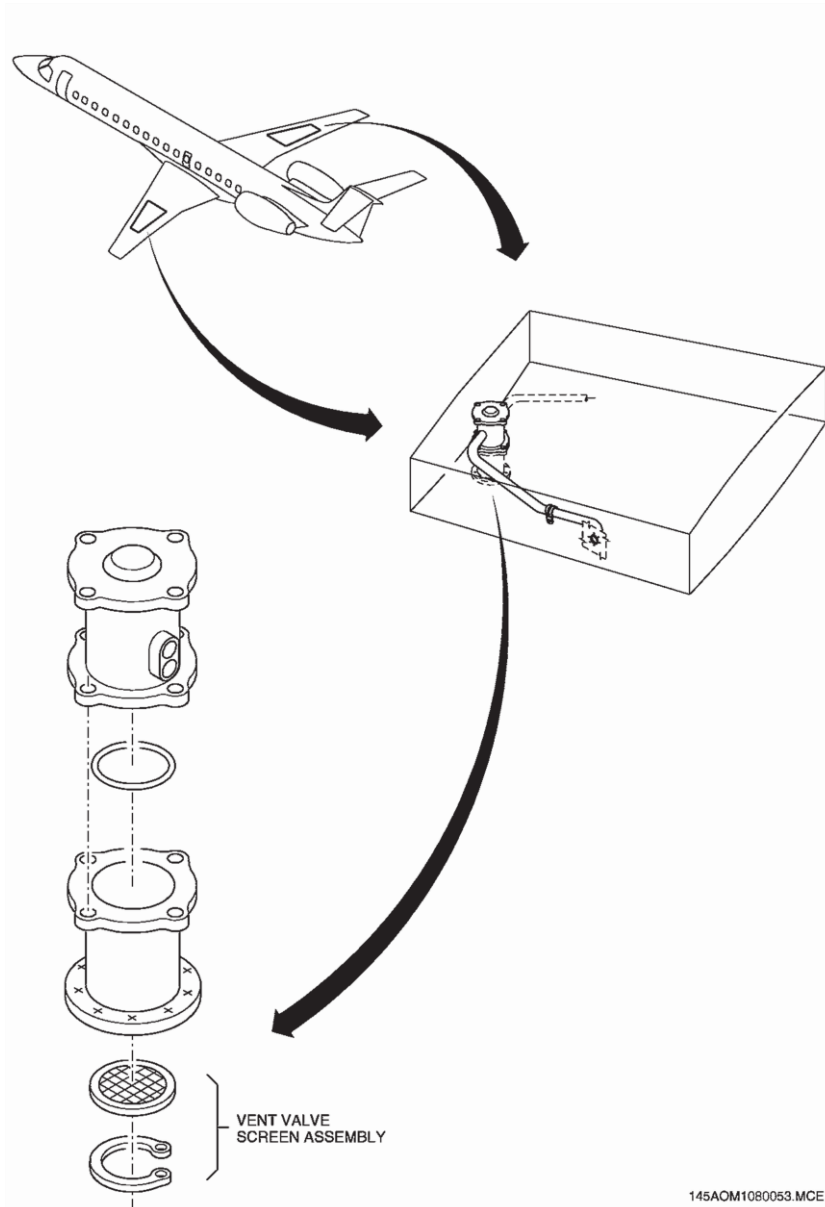
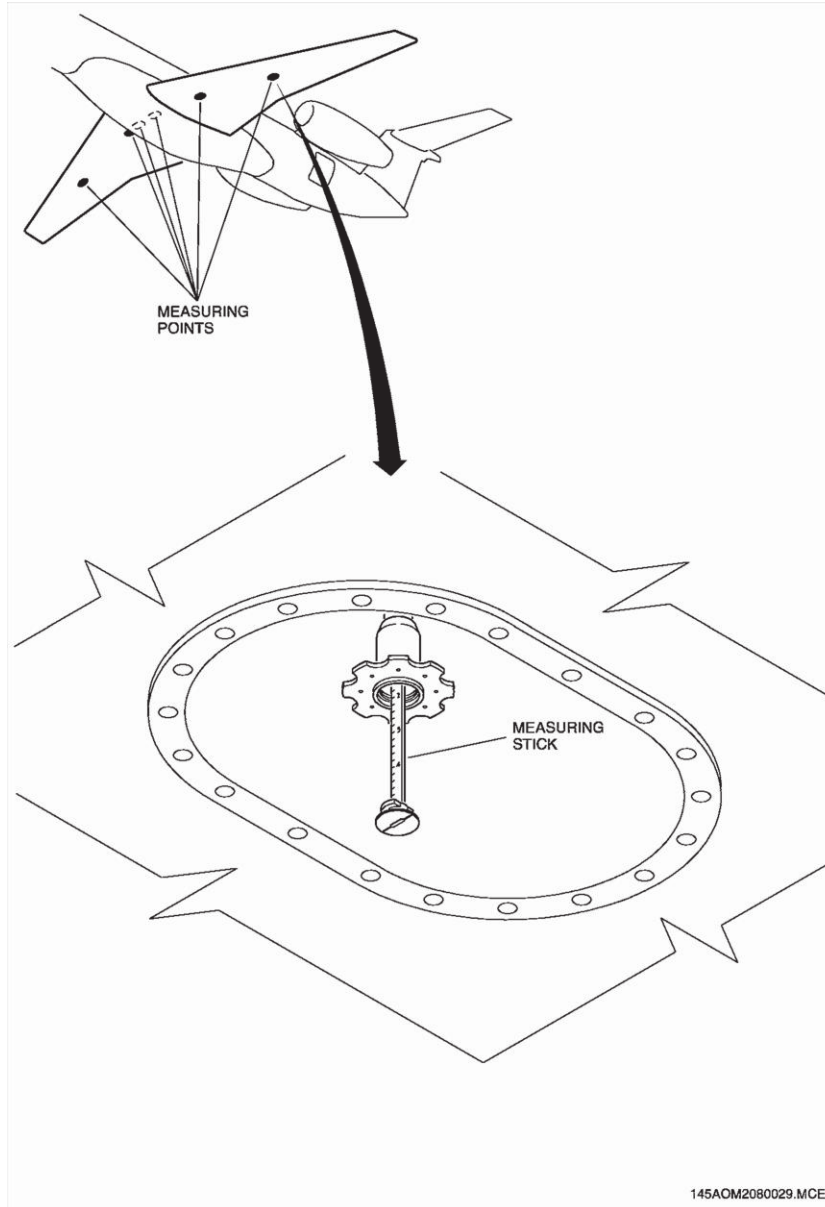

FIGURE 8

1-08-28	Page 2	Code 01
---------	-----------	------------

REVISION 36

AOM-145/1114



**FIGURE
9**

AOM-145/114

REVISION 36

1-08-28	Page 3	Code 01
---------	-----------	------------



MINIMUM EQUIPMENT LIST

EMBRAER 145LR

INTENTIONALL
BLANK

	Page	Code
1-08-28	4	01

REVISION 36

AOM-145/1114

ATA CHAPTER 32 LANDING GEAR

SYSTEM & SEQUENCE ITEM NUMBER	1.	2. NUMBER INSTALLED		4.2 MARKS AND/OR EXCEPTIONS
		3.	NUMBER REQUIRED FOR DISPATCH	
32 LANDING GEAR				
10-1 Main Landing Gear Doors (Figure 10)	2	0	0	May be missing provided maximum airspeed is limited to 250 KIAS / M 0.65, whichever is lower.
10-2 Main Landing Gear Wheels Fairing (Figure 10)	2	0	0	May be missing provided maximum airspeed is limited to 250 KIAS / M 0.65, whichever is lower.

AOM-145/114

REVISION 27

1-08-32	Page 1	Code 01
---------	-----------	------------

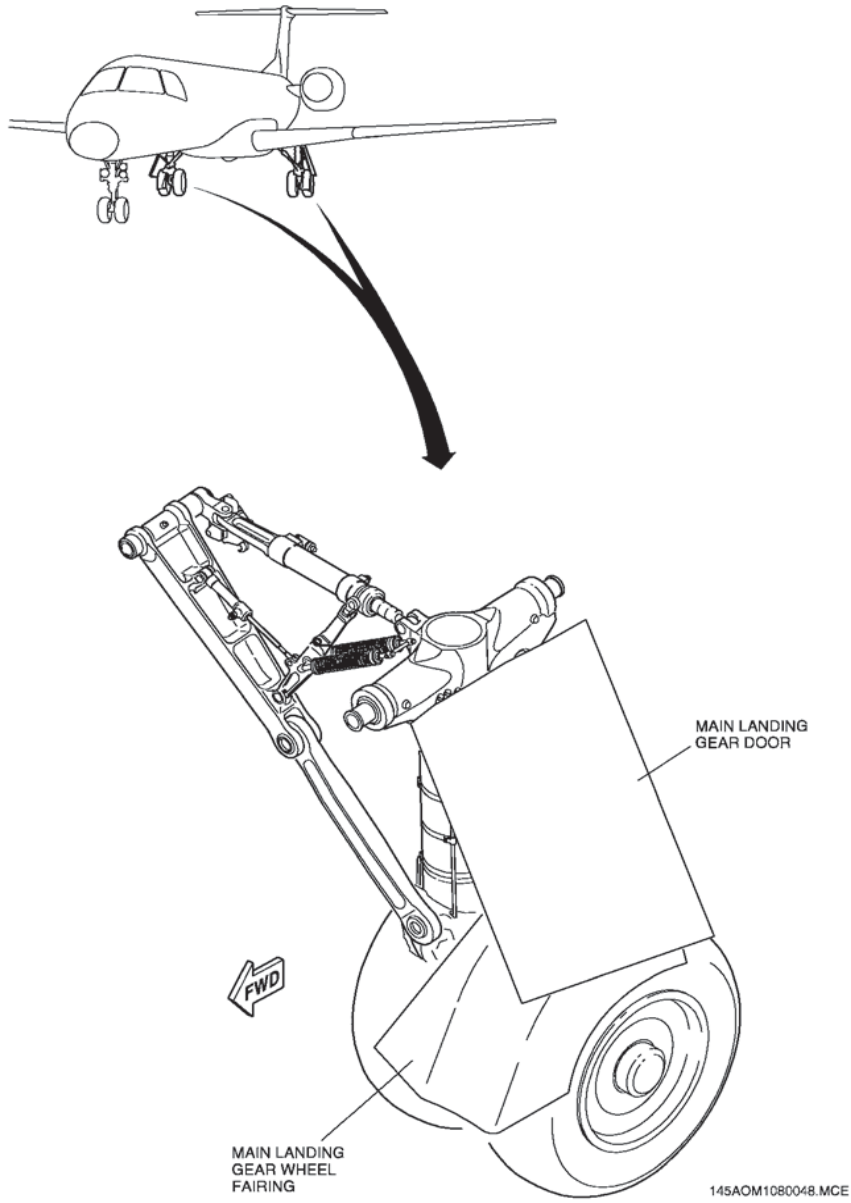

FIGURE10

1-08-32	Page 2	Code 01
---------	-----------	------------

REVISION 27

ACM-145/1114

ATA CHAPTER 33 LIGHTS

System & Sequence ITEM Number	1.	2. Number installed		4. Remarks and/or exceptions
		3.	Number required for dispatch	
33 LIGHTS				
41-1 Nose Landing Light (Figure 11)	1	0		May be missing with no penalty. Refer to MEL 33-41-00.
42-1 Taxi Light (Figure 11)	2	0		May be missing with no penalty. Refer to MEL 33-42-00.
43-1 Navigation Light Protective Lens (Figure 12) (All except EMB-145 R)	3	0		May be missing with no penalty. Refer to MEL 33-43-00.
43-2 Navigation Light Protective Lens (Figure 13) (EMB-145 R)	6	0		May be missing with no penalty. Refer to MEL 33-43-00.
44-1 Inspection Light Protective Lens (Figure 14)	2	0		May be missing with no penalty. Refer to MEL 33-44-00.
46-1 Logotype Light Protective Lens (Figure 15)	2	0		May be missing with no penalty. Refer to MEL 33-46-00.
47-1 Red Beacon Light Protective Lens (Figure 16)	2	0		May be missing with no penalty. Refer to MEL 33-47-05.
50-1 Exterior Emergency Light Protective Lens (Figure 1)	4	0		May be missing with no penalty. Refer to MEL 33-50-00.

AOM-145/1114

REVISION 40

1-08-33	Page 1	Code 01
---------	-----------	------------

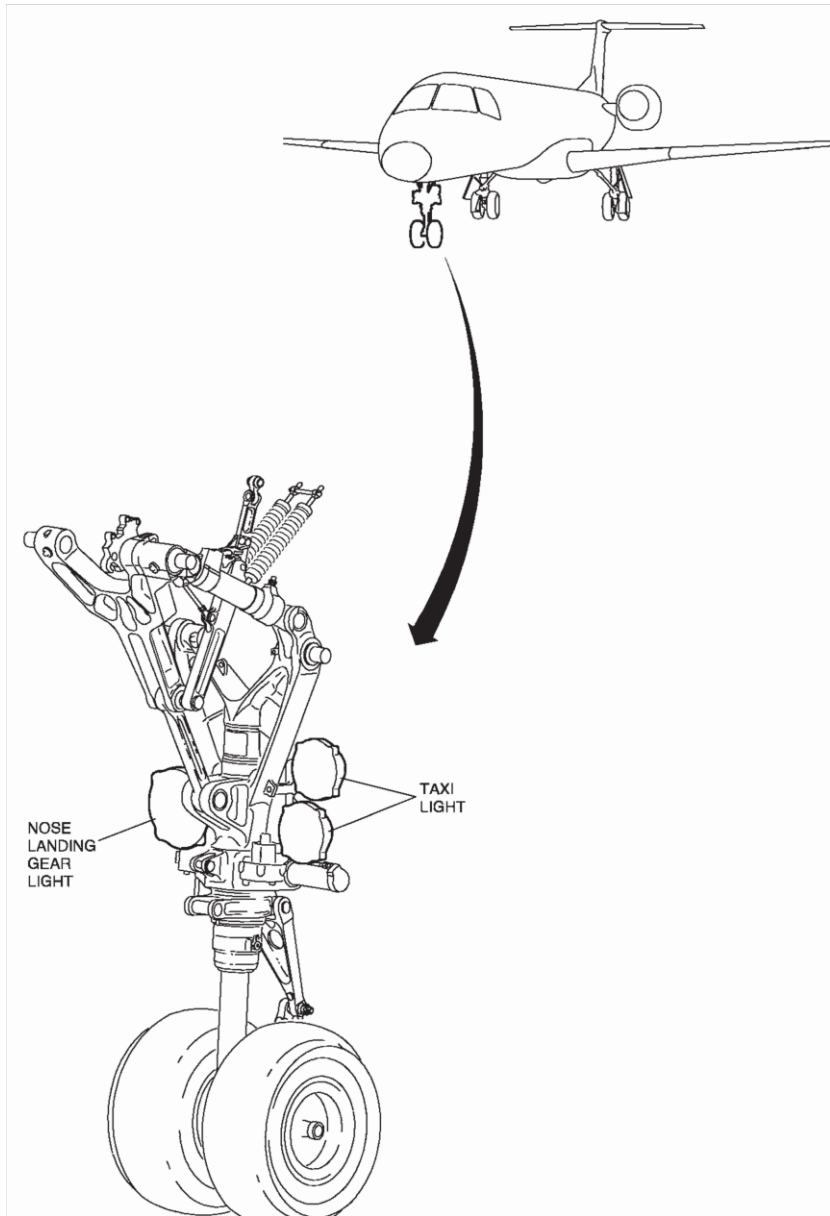

FIGURE 11

1-08-33	Page 2	Code 01
---------	-----------	------------

REVISION 40

AOM-145/114

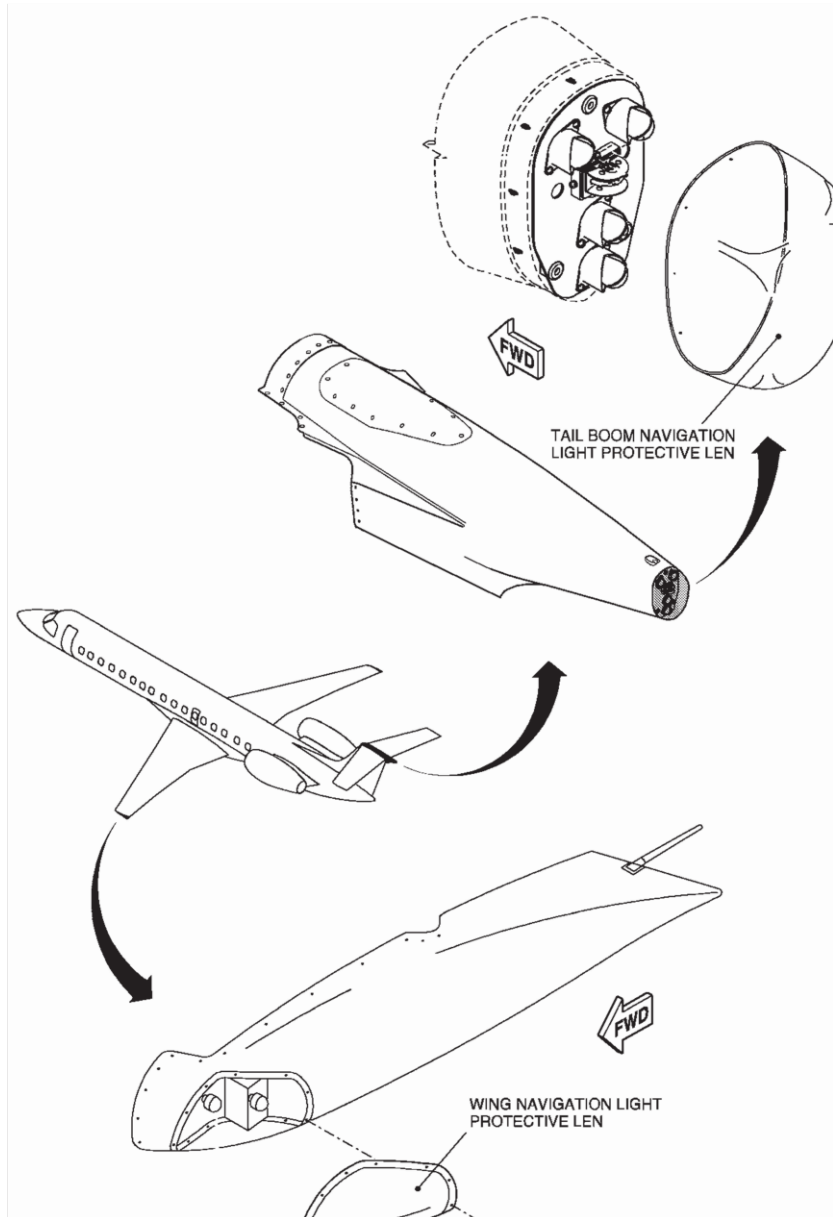

FIGURE 12

AOM-145/114

REVISION 40

1-08-33	Page 3	Code 01
---------	-----------	------------

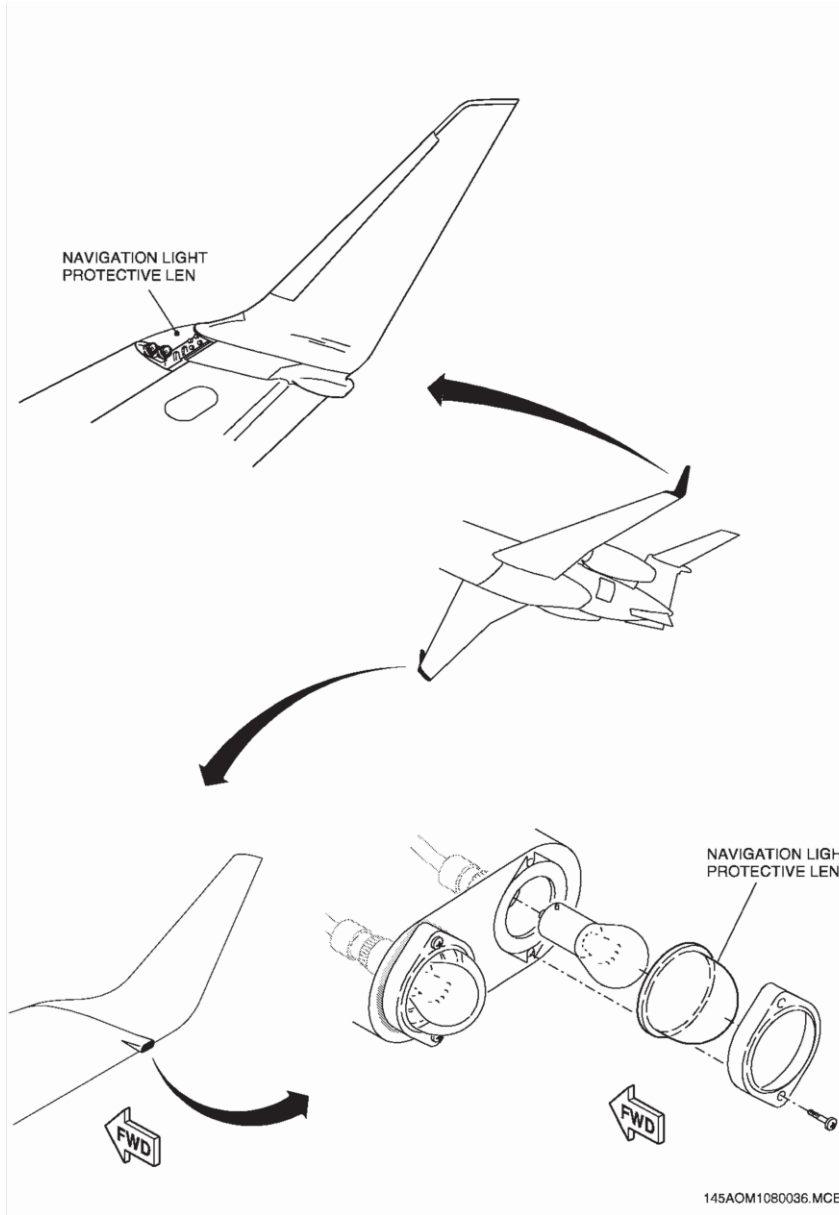

FIGURE 13

1-08-33	Page 4	Code 01
---------	-----------	------------

REVISION 40

AOM-145/114

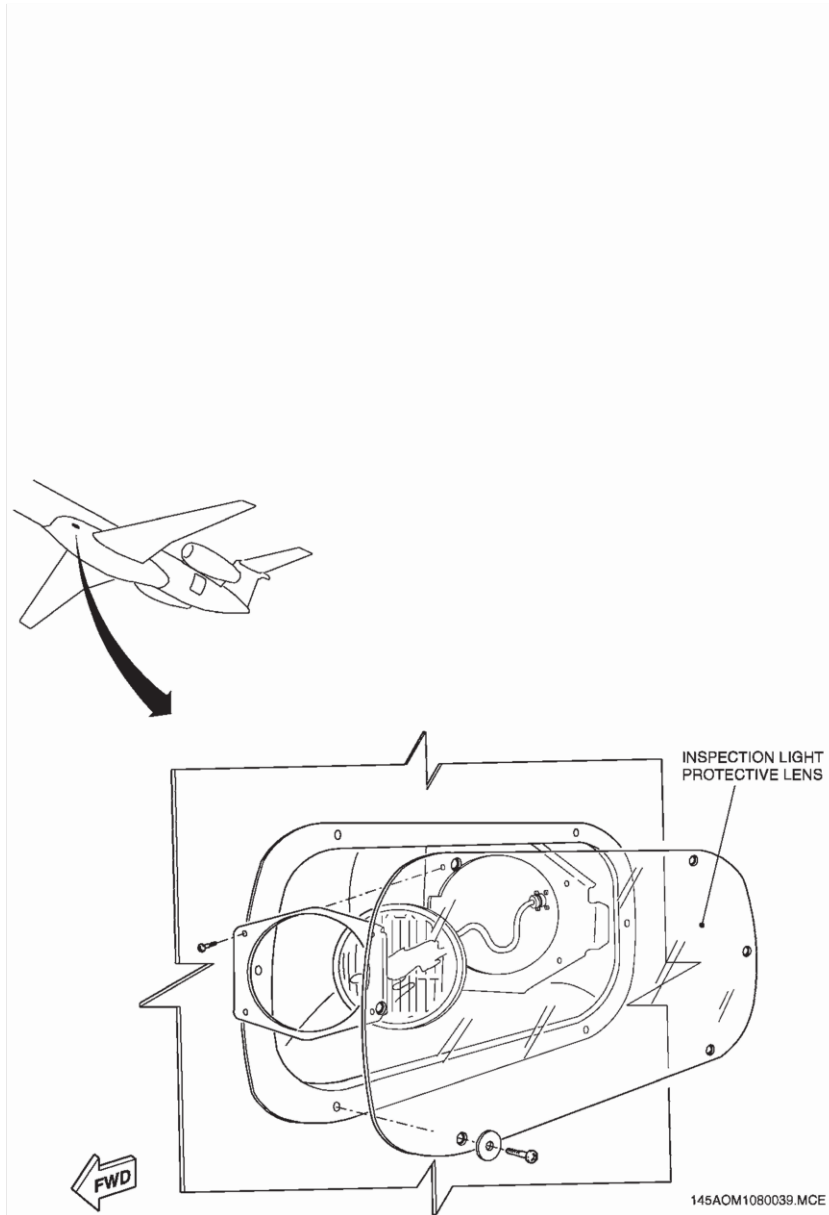

FIGURE 14

AOM-145/1114

REVISION 40

1-08-33	Page 5	Code 01
---------	-----------	------------

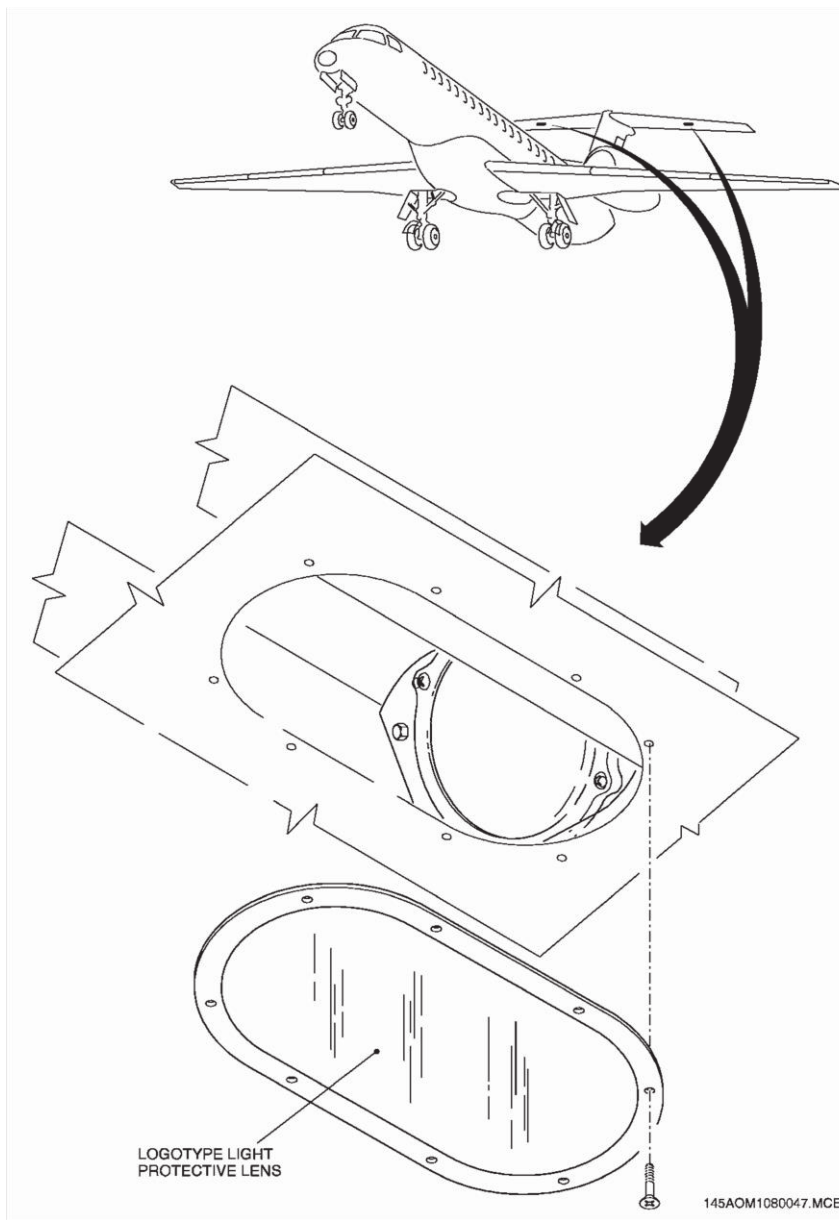
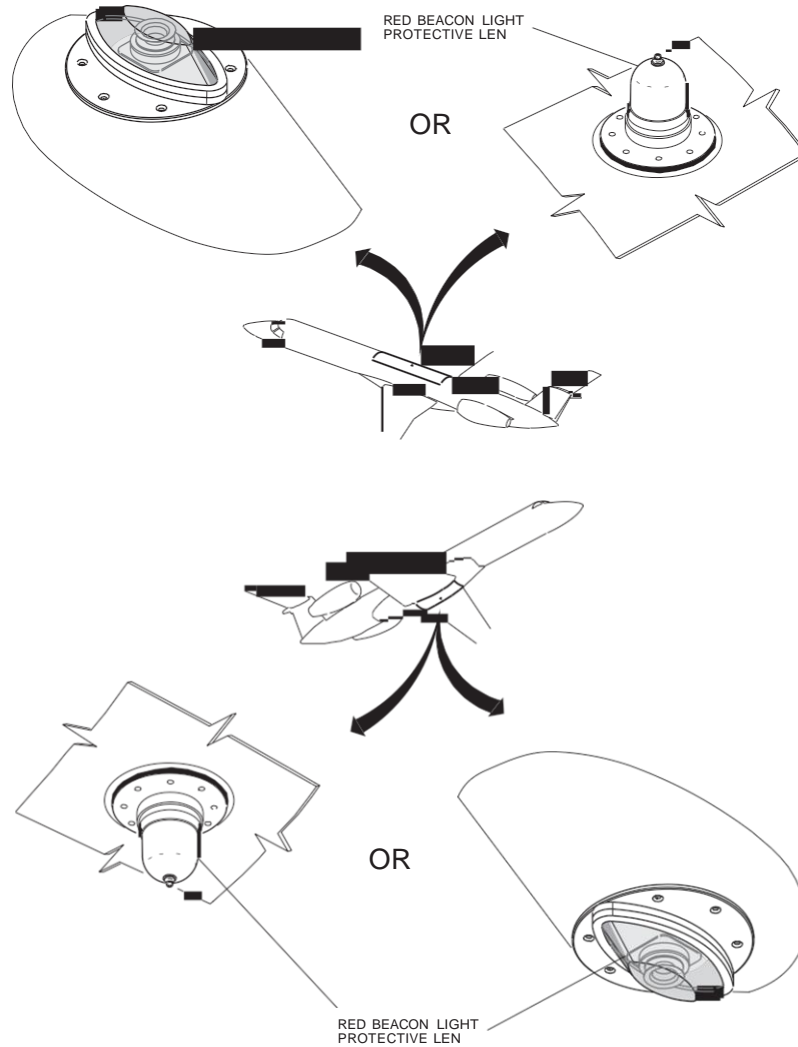

FIGURE 1

1-08-33	Page 6	Code 01
---------	-----------	------------

REVISION 40

AOM-145/114



EM145AOM080025A.DGN

FIGURE 16

AOM-145/1114

REVISION 40

1-08-33	Page	Code
		01

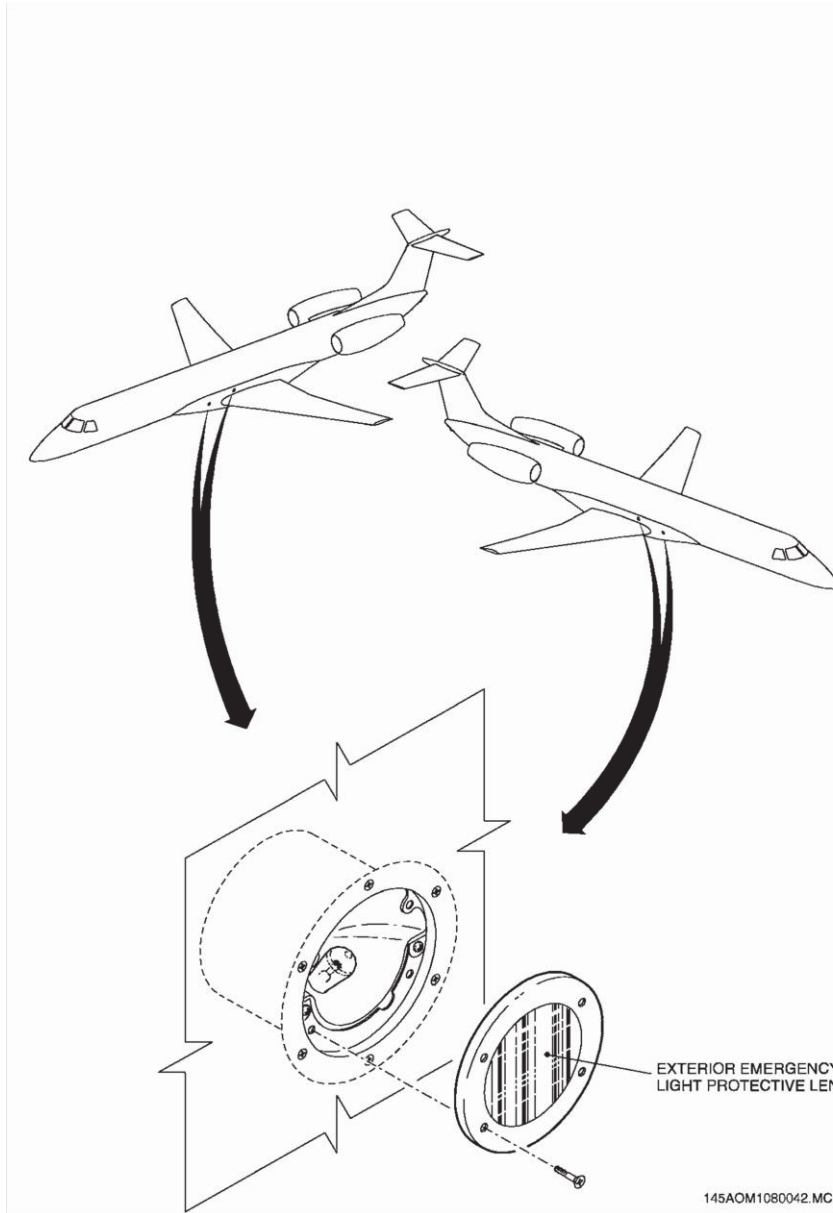

FIGURE 17

1-08-33	Page 8	Code 01
---------	-----------	------------

REVISION 40

AOM-145/114

ATA CHAPTER 49 AUXILIARY POWER UNIT

SYSTEM & SEQUENCE ITEM NUMBER	1.	2. NUMBER INSTALLED		4.2. MARKS AND/OR EXCEPTIONS
		3.	NUMBER REQUIRED FOR DISPATCH	
49 AUXILIARY POWER UNIT				
42-1 APU Starter/Generator Air Intake Scoop (Figure 18)	1	0		May be missing provided APU operates on the ground only.
52-1 APU Compartment Cooling Air Intake Scoop (Figure 18)	1	0		May be missing provided APU operates on the ground only.

ACM-145/114

REVISION 27

1-08-49	Page 1	Code 01
---------	-----------	------------



FIGURA18

1-08-49	Page 2	Code 01
---------	-----------	------------

REVISION 27

ACM-145/1114

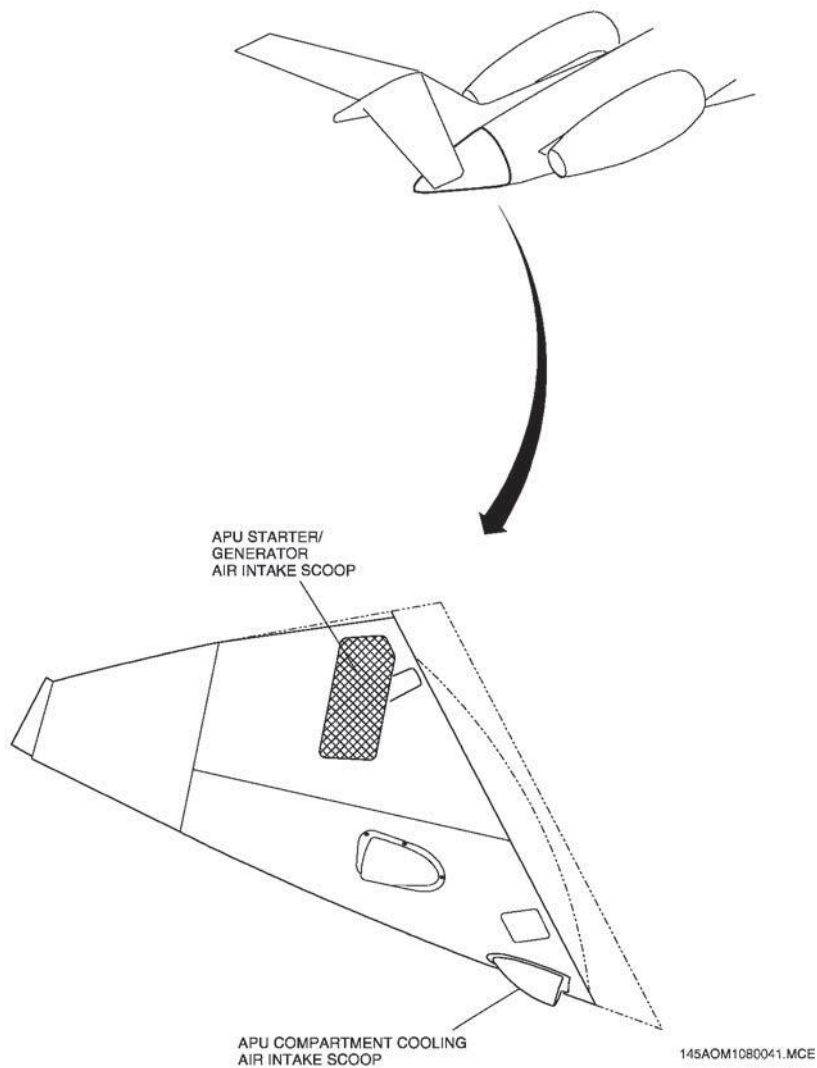
ATA CHAPTER 52 DOORS

SYSTEM & SEQUENCE ITEM NUMBER	1.	2. NUMBER INSTALLED		4.2 MARKS AND/OR EXCEPTIONS
		3.	NUMBER REQUIRED FOR DISPATCH	
52 DOORS				
10-1 Main Door Handgrip (Figure 19)	1	0		May be missing with no penalty.
42-1 Service Door Handgrip (Figure 19)	1	0		May be missing with no penalty.
43-1 Tail Cone Access Door (312AR - Figure 6)	1	0		May be missing with no penalty.

ADM-145/114

REVISION 27

1-08-52	Page 1	Code 01
---------	-----------	------------

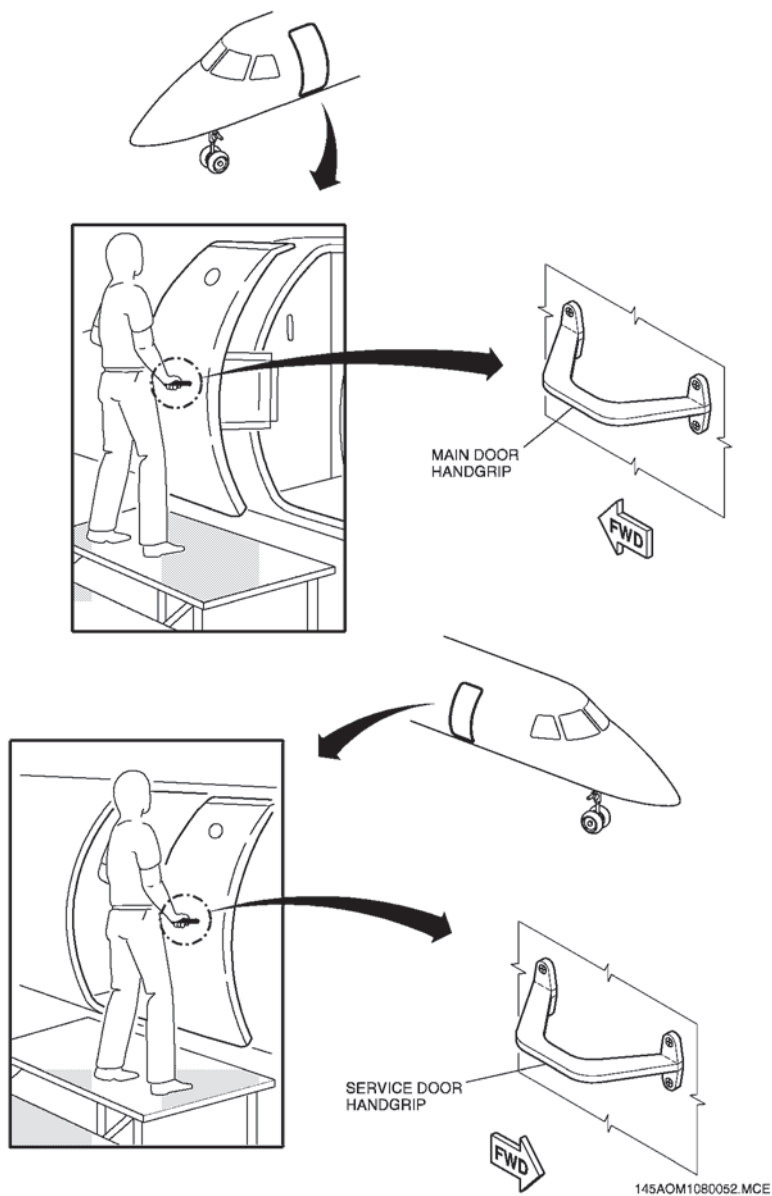

FIGURE19

1-08-52	Page 2	Code 01
---------	-----------	------------

REVISION 27

ACM-145/1114

ATA CHAPTER 54 NACELLE/PYLONS

SYSTEM & SEQUENCE ITEM NUMBER	1.	2. NUMBER INSTALLED		4.2. EMARKS AND/OR EXCEPTIONS
		3.	NUMBER REQUIRED FOR DISPATCH	
54 NACELLE/PYLONS				
50-1 Systems Access Door (414AB/BB/EB - Figure 20) (424AB/BB/EB - Figure 21)	6	4		A maximum of 1 per pylon for a total of 2 may be missing provided maximum airspeed is limited to 250 KIAS / 0.65 M, whichever is lower.
50-2 Bleed Valve Access Door (414DB - Figure 20) (424DB - Figure 21)	2	0		May be missing with no penalty.
50-3 Pre-cooler Access Door (414CB - Figure 20) (424CB - Figure 21)	2	0		May be missing with no penalty.
50-4 Engine Pylon Fairing (414HL - Figure 20) (424HR - Figure 21)	2	0		May be missing with no penalty.

ACM-145/114

REVISION 27

1-08-54	Page 1	Code 01
---------	-----------	------------

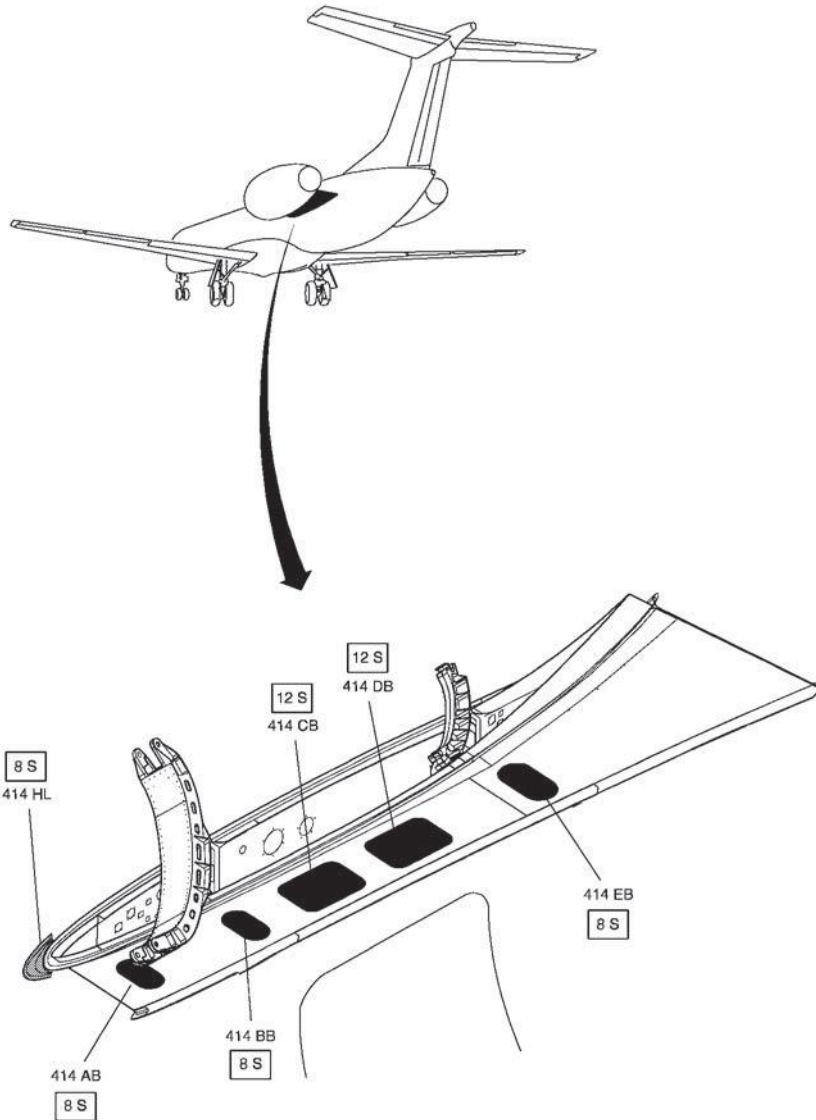

145AOM1080033.MCE

FIGURE20

1-08-54	Page 2	Code 01
---------	-----------	------------

REVISION 27

ACM-145/1114

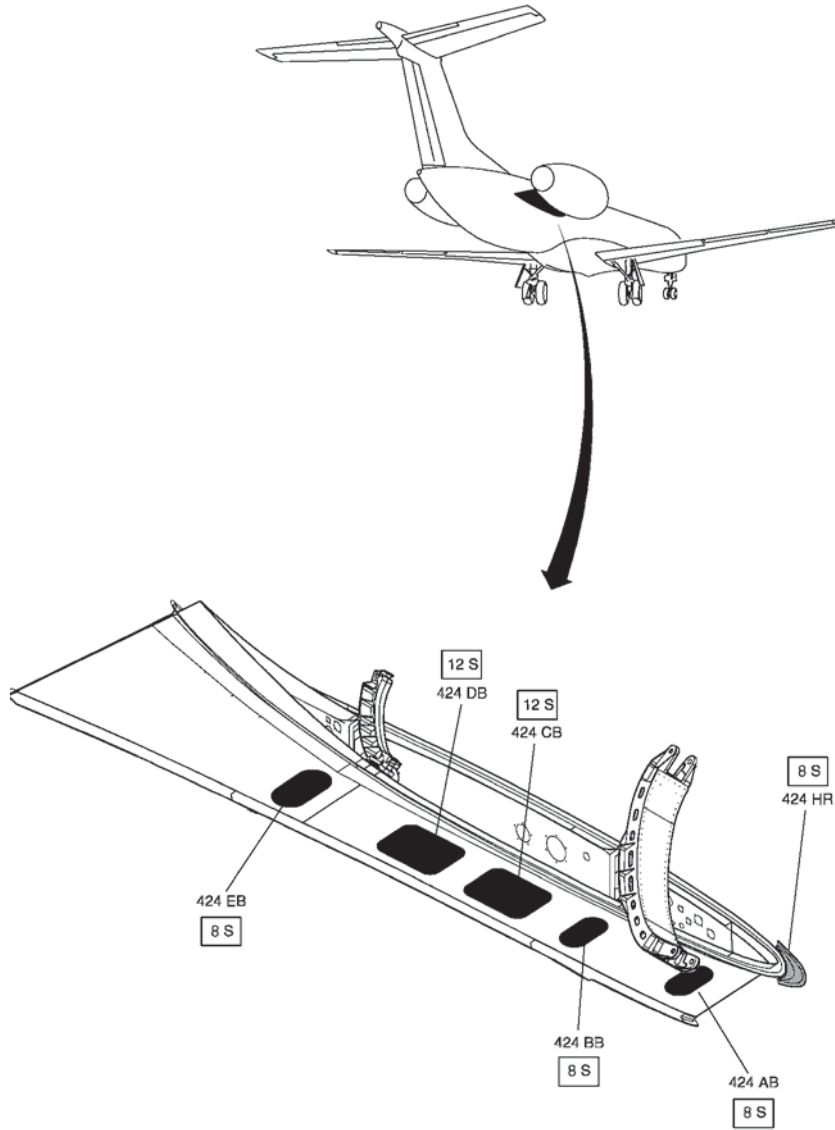

145AOM1080034.MCE

FIGURE21

AOM-145/1114

REVISION 27

1-08-54	Page 3	Code 01
---------	-----------	------------



MINIMUM EQUIPMENT LIST

EMBRAER 145LR

THIS PAGE IS LEFT INTENTIONALLY BLANK

1-08-54	Page 4	Code 01
---------	-----------	------------

REVISION 13

ADM-145/1114

ATA CHAPTER 55 STABILIZERS

SYSTEM & SEQUENCE ITEM NUMBER	1.	2. NUMBER INSTALLED		4.2. MARKS AND/OR EXCEPTIONS
		3.	NUMBER REQUIRED FOR DISPATCH	
55 STABILIZERS				
10-2 Horizontal Stabilizer Access Door (333AB/BB/CB - Figure 22) (334AB/BB/CB - Figure 23)	6	4		A maximum of 1 per side for a total of 2 may be missing with no penalty.
20-2 Elevator Control Rod Fairing (Figure 26)	4	0		May be missing with no penalty.
20-3 Elevator Trim Control Rod Fairing (Figure 26)	2	0		May be missing with no penalty.
20-4 Elevator Access Door (335AB/BB/CB/DB/EB/ FB/GB/HB - Figure 22) (336AB/BB/CB/DB/EB/ FB/GB/HB - Figure 23)	16	15		One may be missing with no penalty. 335AB/BB/CB/DB/EB and 336 AB/BB/CB/DB/EB cannot be missing.
30-1 Vertical Stabilizer Access Door (322AL, 324AL/BL/CL/DL/EL, 325AL/BL/CL/DL/EL - Figure 24) (322BR, 324FR, 325FR/ GR/HR/JR/KR/LR - Figure 25)	19	16		A maximum of 3 in any combination may be missing with no penalty. 324 FR/EL and 325 EL/LR cannot be missing.
40-1 Rudder Access Door (326AL/BL/CL/EL/FL/GL/HL, 327AL/BL/CL/DL - Figure 24) (327ER/FR/GR/HR - Figure 25)	15	13		A maximum of 2 in any combination may be missing with no penalty.

ADM-145/1114

REVISION 27

1-08-55	Page 1	Code 01
---------	-----------	------------

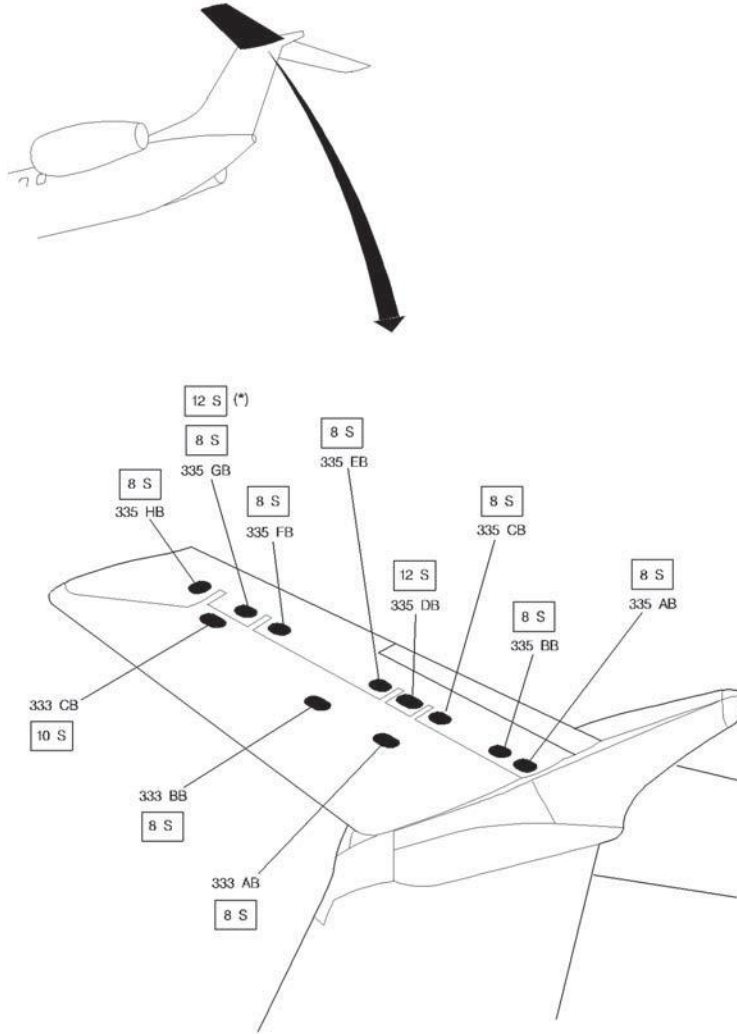

NOTE:
(*) APPLICABLE TO AIRCRAFT 012/999

1451114343.MCE

FIGURE22

1-08-55	Page 2	Code 01
---------	-----------	------------

REVISION 27

ACM-145/1114

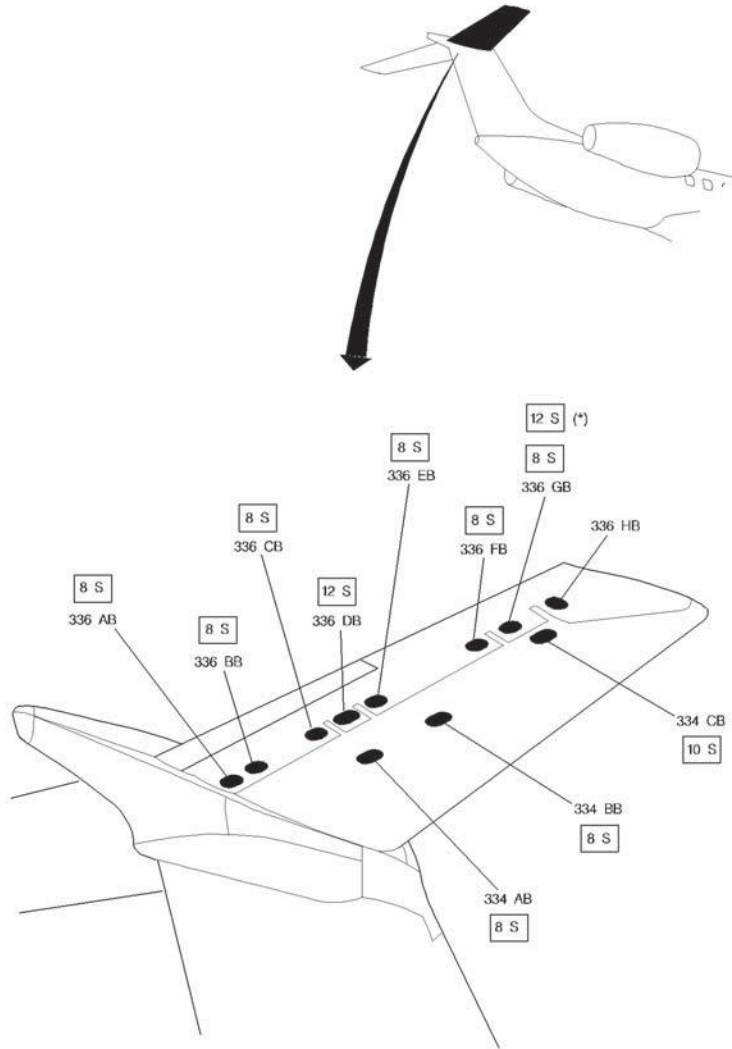

NOTE:
(*) APPLICABLE TO AIRCRAFT 012/999

145114342.MCE

FIGURE23

ADM-145/1114

REVISION 27

1-08-55	Page 3	Code 01
---------	-----------	------------

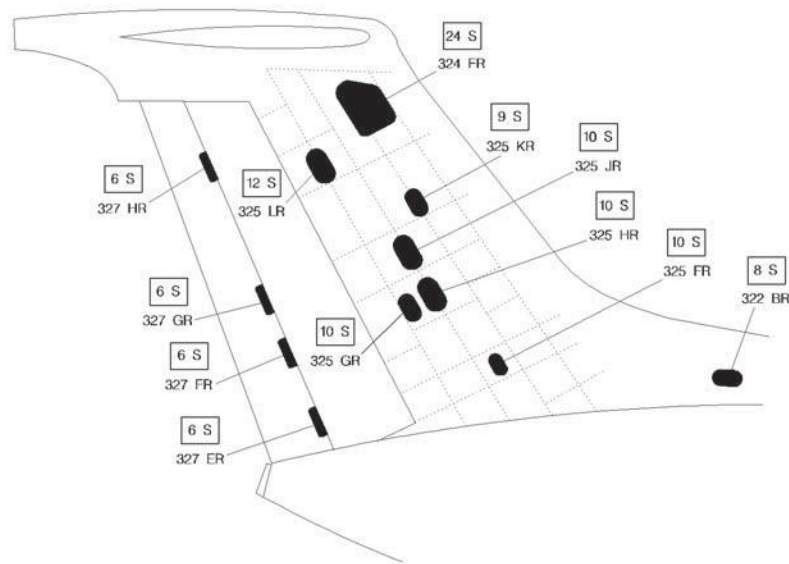

145114345.MCE

FIGURE25

ADM-145/1114

REVISION 27

1-08-55	Page 5	Code 01
---------	-----------	------------

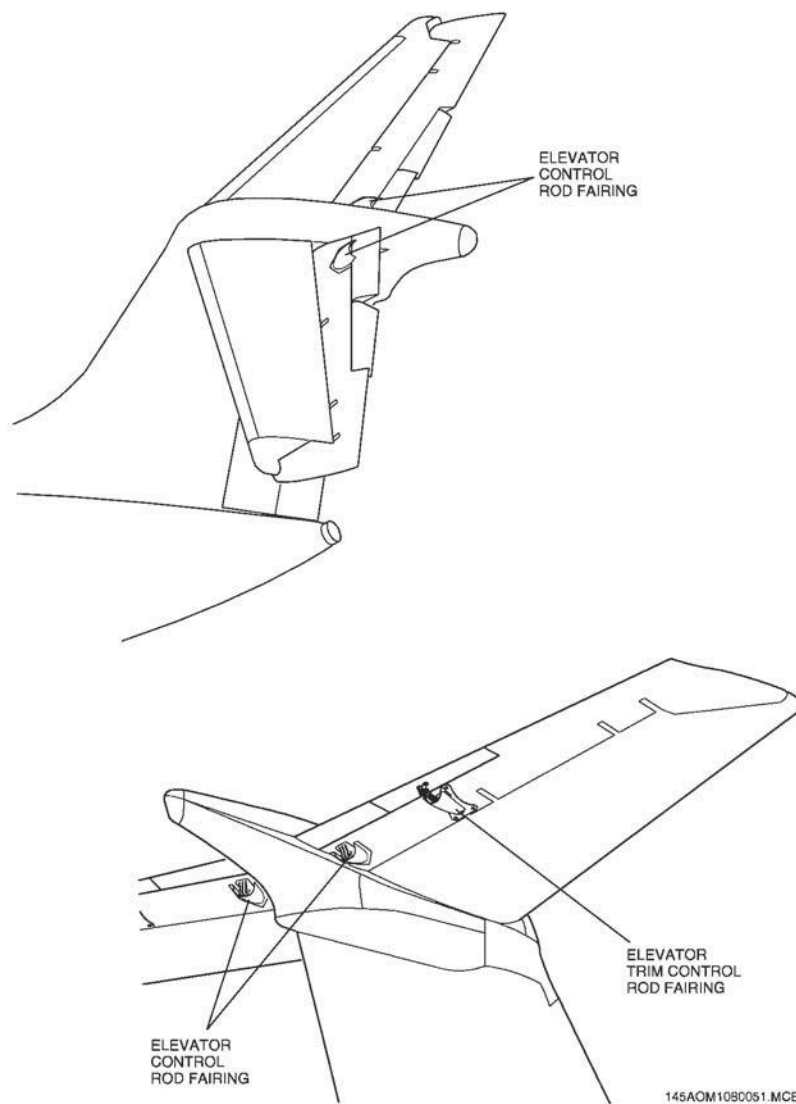

FIGURE26

1-08-55	Page 6	Code 01
---------	-----------	------------

REVISION 27

ACM-145/1114

ATA CHAPTER 57 WINGS

SYSTEM & SEQUENCE ITEM NUMBER	1.	2. NUMBER INSTALLED		4.2. EMARKS AND/OR EXCEPTIONS
		3.	NUMBER REQUIRED FOR DISPATCH	
57 WINGS				
20-1 Vortex Generator (Figure 27)	24	22		A maximum of 1 per wing for a total of 2 may be missing with no penalty.
30-2 Wing Tip Glareshield (Figure 28)	2	0		May be missing with no penalty.
42-1 Wing Grounding Point (Figure 29)	2	0		One or both may be missing with no penalty provided: a) The hole is covered with Scotch Brand Tape (Silver Tape) or similar product and, b) The landing gear grounding point is available.
52-1 Flap Track Fairing (Figure 30)	10	9		One may be missing with no penalty.
52-2 Wing-to-flap seal (Figure 31)	4	3		One may be missing provided maximum airspeed is limited to 250 KIAS / M0.65, whichever is lower.

AOM-145/1114

REVISION 27

1-08-57	Page 1	Code 01
---------	-----------	------------

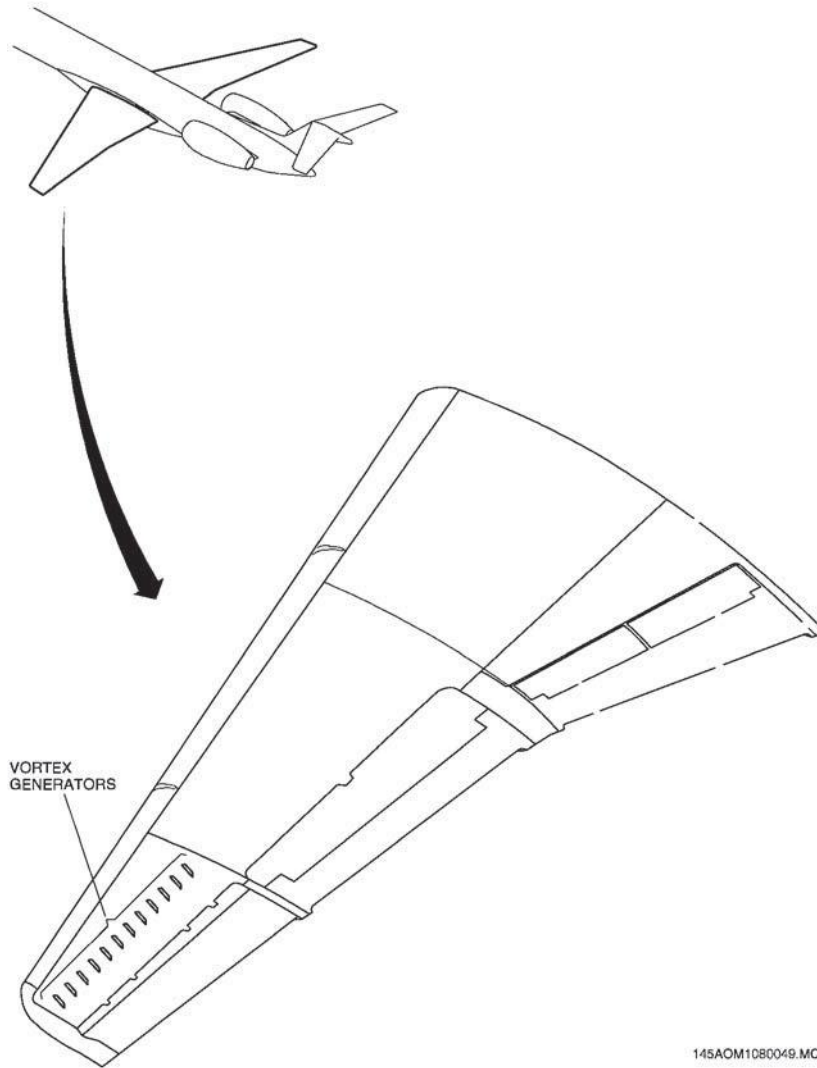

145AOM1080049.MCE

FIGURE27

1-08-57	Page 2	Code 01
---------	-----------	------------

REVISION 27

ACM-145/1114

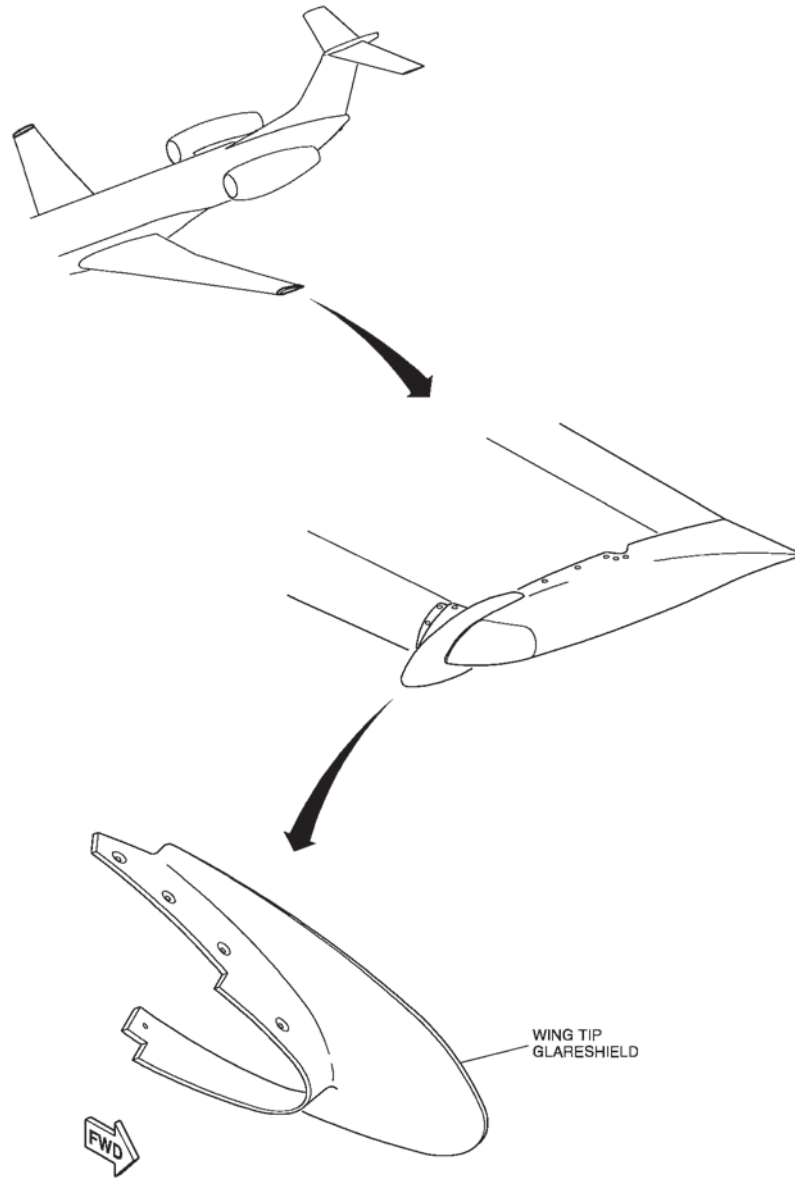

145AOM1080050.MCE

FIGURA28

AOM-145/1114

REVISION 27

1-08-57	Page 3	Code 01
---------	-----------	------------



FIGURA29

1-08-57	Page 4	Code 01
---------	-----------	------------

REVISION 27

AOM-145/1114

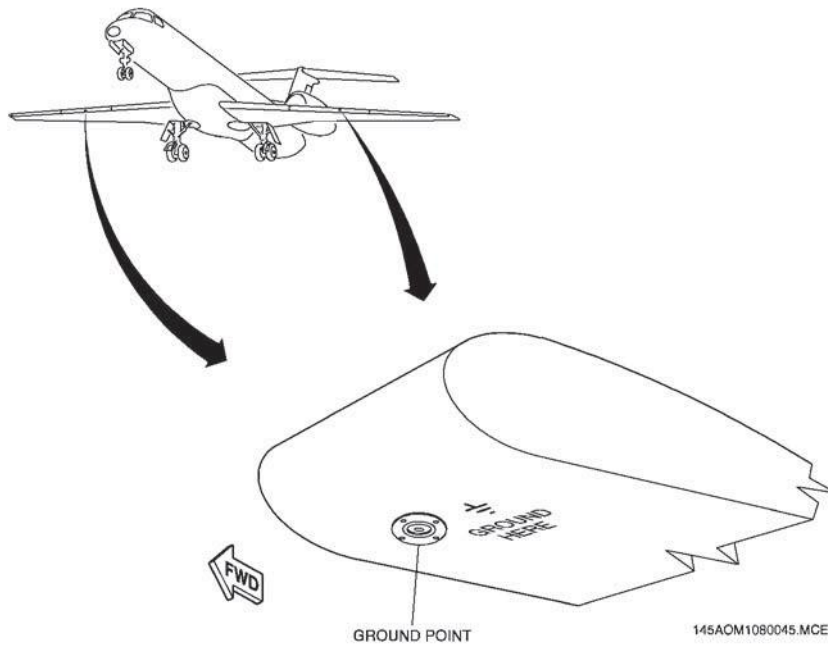

FIGURA30

ACM-145/1114

REVISION 27

1-08-57	Page 5	Code 01
---------	-----------	------------

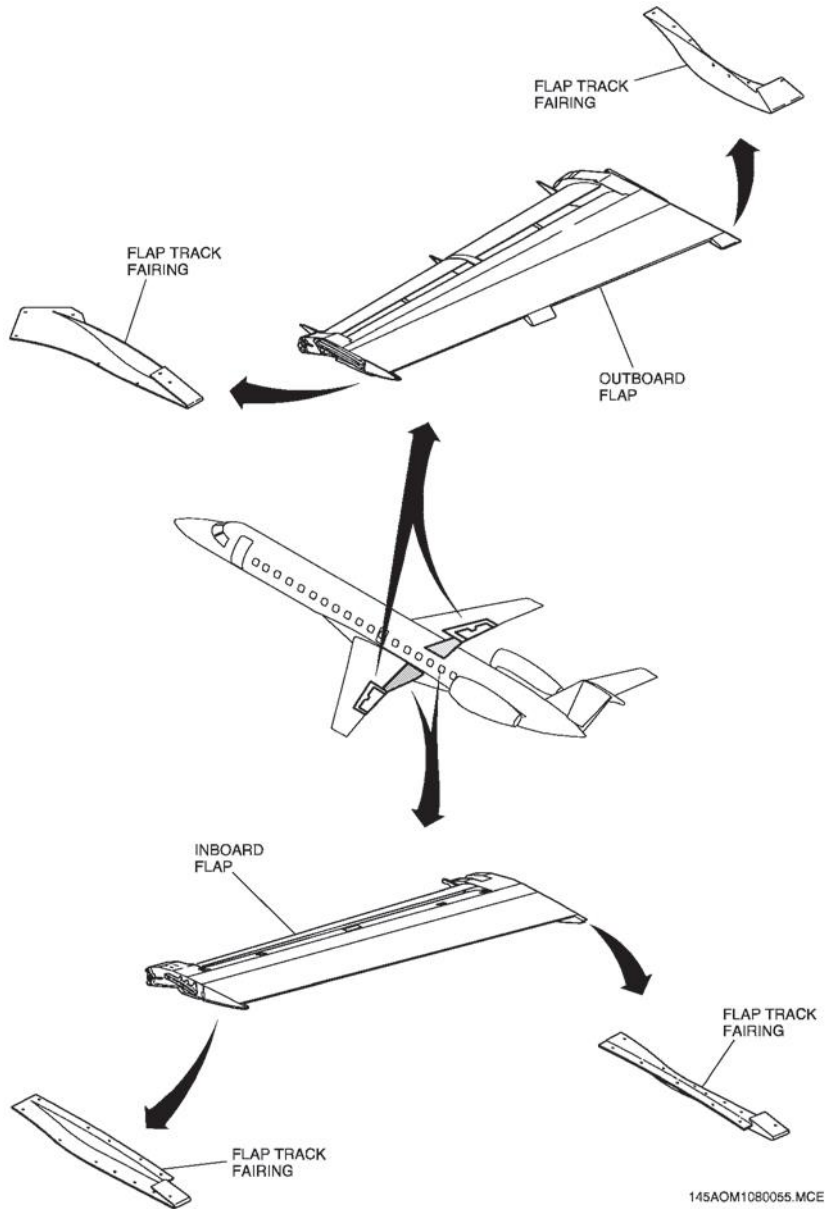

FIGURA31

1-08-57	Page 6	Code 01
---------	-----------	------------

REVISION 27

ACM-145/1114

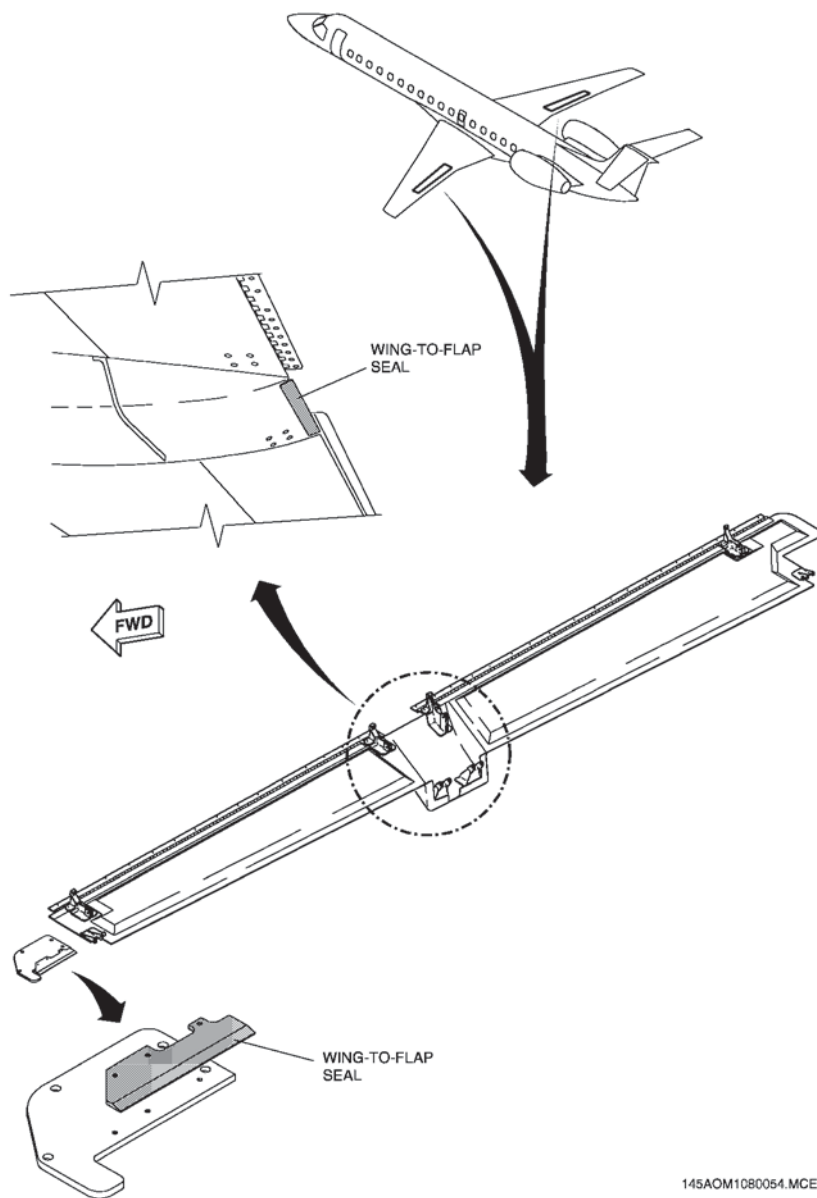
ATA CHAPTER 78 ENGINE EXHAUST

SYSTEM & SEQUENCE ITEM NUMBER	1.	2. NUMBER INSTALLED		3. NUMBER REQUIRED FOR DISPATCH	4.2 MARKS AND/OR EXCEPTIONS
78 ENGINE EXHAUST					
31-1 Plug Inhibition of the Thrust Reversers (Figure 32)	4	0			May be missing with no penalty

ACM-145/114

REVISION 27

1-08-78	Page 1	Code 01
---------	-----------	------------

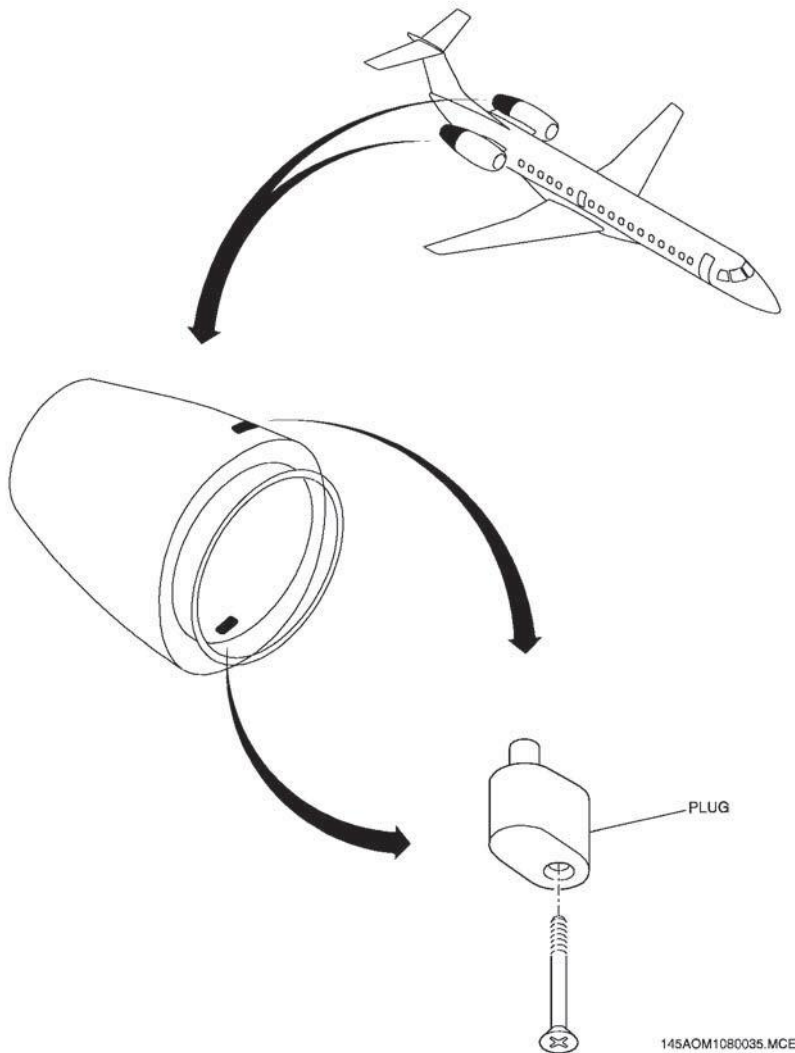

FIGURE32

1-08-78	2	01
---------	---	----



MINIMUM EQUIPMENT LIST

EMBRAER 145LR

NON-ESSENTIAL EQUIPMENT AND FURNISHINGS LIST (NEF LIST)

INTRODUCTION

NEF are those items installed on the airplane as part of the original type certification, supplemental type certificate, or other form of alteration that have no effect on the safe operation of flight and would not be required by the applicable certification rules or operational rules. They are those items that, if inoperative, damaged, or missing, have no effect on the airplane's ability to be operated safely under all operational conditions. These nonessential items may be installed in areas including, but not limited to:

- The passenger compartment.
- Flight deck area,
- Service areas,
- Cargo areas,
- Crew rest areas,
- Lavatories,
- Galley áreas

NEF list are not items already identified in the MEL or CDL of the applicable airplane. They do not include items that are functionally required to meet the certification rule or for compliance with any operational rule. The NEF list shall not provide for deferral of items within serviceable limits identified in the manufacturer's maintenance manual or operator's approved maintenance program such as wear limits, fuel/hydraulic leak rates, oil consumption, etc. Cosmetic items that are fully serviceable but worn or soiled may be deferred under the NEF list. By definition, NEF items do not affect the safe operation of an airplane.

REPAIR INTERVAL

All components included in the NEF list should be repaired in an interval no longer than 120 calendar days.



MINIMUM EQUIPMENT LIST

EMBRAER 145LR

11 PLACARDS AND MARKINGS

DESCRIPTION	REMARKS AND /OR EXCEPTIONS	PROCEDURE
Interior Placards and/or Markings	Non mandatory placards may be missing or damaged.	(M) Mandatory placards will be identified by maintenance and may be degraded butlegible
Exterior Placards and/or Markings	Non mandatory placards may be missing or damaged.	(M) Mandatory placards will be identified by maintenance and may be degraded butlegible

21 AIR CONDITIONING

DESCRIPTION	REMARKS AND /OR EXCEPTIONS	PROCEDURE
Air Conditioning Service Bays Dust Cap Chains and/or Lanyards	May be missing or damaged.	

23 COMMUNICATIONS

DESCRIPTION	REMARKS AND /OR EXCEPTIONS	PROCEDURE
Call system passenger-fly attendants	May be innoperative.	

24 ELECTRICAL POWER

DESCRIPTION	REMARKS AND /OR EXCEPTIONS	PROCEDURE
Battery Compartment Dust Caps/Covers	May be missing or damaged.	
Hold Open Rods/Lanyards	May be missing or damaged.	



MINIMUM EQUIPMENT LIST

EMBRAER 145LR

25 EQUIPMENT AND FURNISHINGS (FLIGHT COMPARTMENT)

DESCRIPTION	REMARKS AND /OR EXCEPTIONS	PROCEDURE
Trim/ Covers/ Lenses and Caps	May be missing or damaged.	
Crew Gasper Outlets.	May be inoperative or damaged.	
Logo Insignia	May be missing or damaged.	
Pen Holders.	May be missing or damaged.	
Floor Boards/ Floor Coverings	May be soiled or worn.	
Crew Seat Upholstery	May be soiled or worn.	
Crew Seat Trim	May be missing or damaged.	
Access Compartment Latches	May be missing or damaged.	
Coat/Hat Hooks	May be missing or damaged.	
Circuit Breaker Guards/Collars	May be missing or damaged.	
Document Holder	May be missing or damaged.	
Spare Bulb Kit and Contents	May be missing or damaged.	
Microphone Holder	May be missing or damaged.	
Middle Grab Handle	May be missing or damaged.	
Cockpit Lining	May be damaged provide: a) Holes and free components are not allowable, and b) Cracks are acceptable since correct panel mounting is not affected.	
Protector Overhead Panel	May be damaged provided: a) Holes are not allowable, b) Cracks are acceptable since correct panel mounting is not affected.	
Pedal Assembly Lining	May be damaged provided: a) Holes are not allowable, b) Cracks are acceptable since correct panel mounting is not affected.	



MINIMUM EQUIPMENT LIST

EMBRAER 145LR

25 EQUIPMENT AND FURNISHINGS (FLIGHT COMPARTMENT) (continued)

DESCRIPTION	REMARKS AND /OR EXCEPTIONS	PROCEDURE
Glareshield Coverage	May be damaged provided: a) Holes are not allowable, b) Cracks are acceptable since correct panel mounting is not affected.	
Control Column Linings	May be damaged provided flight controls operate normally.	
Cockpit Pedal Covers	May be damaged provided: a) Holes and free components are not allowable, and b) Cracks are acceptable since correct panel mounting is not affected	
Cockpit Ashtray(s)	May be missing or damaged.	
Cockpit Cup Holders	May be missing or damaged.	
Cockpit Foot Rests	May be missing or damaged.	
Control Yoke Rubber Hand Grip	May be missing or damaged.	
Cockpit Seat Headrest(s)	May be missing or damaged.	
Cockpit Finishing Parts	May be stained/torn/damaged provided: a) Holes are not allowable, b) Cracks are acceptable since correct panel mounting is not affected. (M) A Scotch Brand Tape (Silver Tape) or similar product may be used to cover the holes.	
Window Sunshade	May be missing or damaged.	
Dual USB charging Port	May be missing or damaged.	



MINIMUM EQUIPMENT LIST

EMBRAER 145LR

25 EQUIPMENT AND FURNISHINGS (PASSENGER COMPARTMENT)

DESCRIPTION	REMARKS AND /OR EXCEPTIONS	PROCEDURE
Trim/ Covers/ Lenses and Caps	May be missing or damaged.	
Carpet/Floor Covering	May be soiled or worn.	
Seat Track Covers	May be missing or damaged.	
Wall Coverings	May be worn or damaged.	(M) May be worn or damaged provided do not exceed damage limits allowed according to SRM.
Ancillary Kit	May be missing or incomplete.	
Demo Equipment	Any in excess of those required may be inoperative or missing.	
Seat Belt Extenders	May be missing.	
Passenger Seat Trim	May be missing or damaged or worn provided seat operation is not affected	
Individual Passenger Gasper Outlets	May be inoperative or damaged.	
Passenger Reading Lights	May be inoperative or damaged.	
Flight Attendant Seat Trim or Coverings	May be missing or damaged provided function of the seat is not compromised.	
Jump Seat Reading Lights	May be inoperative provided remaining lighting is sufficient for cabin attendant to perform assigned duties.	
Headliner	May be damaged provided: a) Holes components are not allowable, and b) Cracks are acceptable since correct panel mounting is not affected.	(M) Check damage does not pose any safety hazard to occupants and must not impede emergency egress
PSU/Service Unit	May be damaged provided oxygen masks work properly.	(M) Check damage does not pose any safety hazard to occupants and must not impede emergency egress.
Overhead Bin Trim/Dustcovers/Strips/Caps	May be inoperative or missing provided bin.	



MINIMUM EQUIPMENT LIST

EMBRAER 145LR

25 EQUIPMENT AND FURNISHINGS (PASSENGER COMPARTMENT) (continued)

DESCRIPTION	REMARKS AND /OR EXCEPTIONS	PROCEDURE
Sidewall Lining Panels	May be damaged/loose provided damage at emergency window region and free panel is not allowable.	(M) Check damage does not pose any safety hazard to occupants and must not impede emergency egress.
Skirting Lining Panels	May be damaged provided free panel is not allowable.	(M) Check damage does not pose any safety hazard to occupants and must not impede emergency egress.
Main Door Lining Panels	May be damaged/loose and mandatory placards are installed	
Service Door Lining Panels	May be damaged/loose and mandatory placards are installed	
Main-Door Trim Shroud Assembly	May be damaged	
Service-Door Trim Shroud Assembly	May be damaged provided handle stays firm.	
Escape-Hatch Trim Shroud Assembly	May be damaged provided emergency exit works properly	
Window Reveal Assembly	May be crazed/moisture between panes and damaged is allowable only at window frame.	(M) Check damage does not pose any safety hazard to occupants and must not impede emergency egress
LH/RH Valance Panel	May be damaged/loose.	
Escutcheon	May be damaged/loose	
Windows Transparency	May be dirty/minor insignificant damage	
Windows Shade	May be damaged/will not move	
Closets Trim/Panel/Hangers/Shelves	May be missing, damaged or worn	
Passenger Cabin Floor Lining	May be stained/torn/worn.	(M) Check for no delamination at floor panel, check striplight in order to not pose any safety hazard to occupants and must not impede emergency egress.



MINIMUM EQUIPMENT LIST

EMBRAER 145LR

25 EQUIPMENT AND FURNISHINGS (PASSENGER COMPARTMENT) (continued)

DESCRIPTION	REMARKS AND /OR EXCEPTIONS	PROCEDURE
Cockpit-Passenger Cabin Partition	May be stained/torn/worn.	(M) Check for no delamination at panels
Forward Baggage Compartment Partition	May be damaged provided do not exceed maximum and type of damage limits allowed according to AMM 25-27-02-8.	
Toilet Partition-Aft Compartment Partition	May be damaged/ stained/ torn /worn	(M) provided door and blow-out panels Works properly. In case of slide door installed, check for panel delamination.
LH/RH Windscreen	May be dirty/ minor insignificant damage	
Main Door Curtain/Curtains	May be damaged/torn	
Aft Compartment Curtain	May be damaged/torn	
Galley Curtain	May be damaged/torn	
Aft Cabin Partition	May be stained/torn/worn.	
Cockpit Cabin Curtain	May be damaged/torn	
Forward Compartment Partition	May be damaged.	
Class Partition	May be stained/torn/worn	
Class Curtain	May be damaged/torn.	
Lavatory/Baggage Door Microswitch	May be damaged	
Lavatory/Baggage Door Microswitch	May be damaged.	
Aft Cabin Curtain	May be damaged/torn	
Forward Cabin Curtain	May be damaged/torn	
Aft Pocket Door Cover	May be damaged/loose	
Forward Pocket Door Cover	May be damaged/loose	



MINIMUM EQUIPMENT LIST

EMBRAER 145LR

25 EQUIPMENT AND FURNISHINGS (GALLEY)

DESCRIPTION	REMARKS AND /OR EXCEPTIONS	PROCEDURE
Mirrors	May be damaged.	
Galley Work Tables	May be inoperative or missing	
Galley Floor Mats	May be worn, soiled or missing.	
Forward/Aft Galley	May be damaged/loose provided damage at attachments region is not allowable	
Outboard Galley	May be damaged/loose provided damage at attachments region is not allowable	
LH/RH Galley	May be damaged/loose provided damage at attachments region is not allowable.	
Hot Jug	May be inoperative provided will not heat	
Microwave	May be inoperative provided will not heat	
Oven	May be inoperative provided will not heat	
Coffee Maker	May be inoperative provided will not heat	
Galley Microswitches	May be inoperative	
Refrigerator	May be inoperative provided will not refrigerate.	



MINIMUM EQUIPMENT LIST

EMBRAER 145LR

25 EQUIPMENT AND FURNISHINGS (LAVATORIES)

DESCRIPTION	REMARKS AND /OR EXCEPTIONS	PROCEDURE
Lavatory Assist Handles	May be missing or damaged	
Diaper Changing Table	May be missing or damaged	
Seal Strip on Lavatory Door	May be missing or damaged	
Soap or Sanitizer Dispenser	May be missing or damaged	
Toilet Paper Roller	May be missing or damaged	
Toilet Seat	May be inoperative or missing	
Toilet Seat Lid	May be inoperative or missing	
Lavatory Door Lock	May be inoperative provided lavatory is considered inoperative and secured closed	(M) Put a note on the bathroom door that says "inoperative" and lock the door out
Lavatory Door	May be damaged provided damage is insignificant and door must be checked.	
Toilet Shroud Assembly	May be damaged provided damage does not pose any safety hazard to occupants	(M) Verify that the damage does not pose any safety hazard to occupants
Lavatory Closet Assembly	May be damaged provided damage does not pose any safety hazard to occupants	(M) Verify that the damage does not pose any safety hazard to occupants
Lavatory Soap Dispenser	May be broken/missing	(O) Order supplied solid soap to the bathroom
Vanity Mirror	May be damaged.	
Vanity Mirror Lights	May be inoperative or missing	
Sink Drain Screen	May be inoperative or missing	
Soap Holder	May be inoperative or missing	
Faucet Aerator	May be inoperative or missing	
Hot and Cold Faucet Indicators	May be inoperative or missing	



MINIMUM EQUIPMENT LIST

EMBRAER 145LR

25 EQUIPMENT AND FURNISHINGS (LAVATORIES) (continued)

DESCRIPTION	REMARKS AND /OR EXCEPTIONS	PROCEDURE
Deodorizer Holder.	May be inoperative or missing	
Paper Towel or Tissue Holder	May be inoperative or missing.	
Interior Wall Trim or Coverings	May be worn or damaged	
Air Grill Covers	May be missing or damaged.	
Floor Mats	May be missing or damaged.	
Lavatory Slide Door	May be damaged provided damage is insignificant and door must be checked.	
Aft Pocket Door	May be damaged.	
Lavatory Swing Door	May be damaged	
Lavatory Door Latch	May be inoperative provided lavatory is considered inoperative and secured closed.	(M) Put a note on the bathroom door that says "inoperative" and lock the door out

25 EQUIPMENT AND FURNISHINGS (BAGGAGE COMPARTMENT)

DESCRIPTION	REMARKS AND /OR EXCEPTIONS	PROCEDURE
Trim Piece	May be damaged provided fire resistance or sealed compartment integrity is not compromised.	(M) Refer to AMM/SRM for allowable limits
Grills Smoke Detector or Vent	May be damaged.	
Cargo Floor Panels	May be worn or damaged	(M) Refer to AMM/SRM for allowable limits.
Anti-skid Paint	May be worn, soiled or missing	
Non Slip Tape	May be worn, soiled or missing	
Baggage Compartment Anti Blockage Barrier	May be damaged provided do not exceed Anti-Blockage Barrier repair limits according to AMM 25-50-01-8.	



MINIMUM EQUIPMENT LIST

EMBRAER 145LR

25 EQUIPMENT AND FURNISHINGS (BAGGAGE COMPARTMENT) (continued)

DESCRIPTION	REMARKS AND /OR EXCEPTIONS	PROCEDURE
Cargo Loading/Unloading Ramp	May be damaged provided damage does not affect correct door closing or does not pose any damage to the baggage	
Ramp Assembly	May be damaged	
Towbar Head Support and Towbar Support	May be damaged/loose	
Coat Hanger	May be damaged/loose.	
Baggage Door Lining	May be damaged.	
Baggage Compartment Floor Lining	May be damaged provided damage does not affect floor panel	

25 EQUIPMENT AND FURNISHINGS (EMERGENCY)

DESCRIPTION	REMARKS AND /OR EXCEPTIONS	PROCEDURE
Emergency Floor Light Cover	May be damaged.	

28 FUEL

DESCRIPTION	REMARKS AND /OR EXCEPTIONS	PROCEDURE
Fuel Cap Lanyard	May be missing or damaged.	

29 HYDRAULIC POWER

DESCRIPTION	REMARKS AND /OR EXCEPTIONS	PROCEDURE
Hydraulic Service Bays Dust Cover Caps for Service Ports	May be missing or damaged	
Dust Cap Chains or Lanyards	May be missing or damaged.	

**MINIMUM EQUIPMENT LIST****EMBRAER 145LR****38 WATER/WASTE**

DESCRIPTION	REMARKS AND /OR EXCEPTIONS	PROCEDURE
Lavatory Service Dust Caps for Service Ports	May be missing or damaged	
Dust Cap Chains or Lanyards	May be missing or damaged.	

52 DOORS

DESCRIPTION	REMARKS AND /OR EXCEPTIONS	PROCEDURE
Main Passenger Door Internal Trim	May be missing or damaged	
Main Door Trim Panel or Fairing	May be damaged	
Door Panel Lanyards	May be missing or damaged	
Cargo Door Rubber Trim Seal or Dust Seal	May be missing or damaged	
Cargo Door Trim Panel or Fairing	May be missing or damaged	
Service Door Rubber Trim Seal or Dust Seal	May be missing or damaged	
Service Door Trim Panel or Fairing	May be missing or damaged	

53 FUSELAGE

DESCRIPTION	REMARKS AND /OR EXCEPTIONS	PROCEDURE
Fuselage Paint/Company Colors	May be missing or damaged	

ANEXO 1. NORMATIVO TIPOS, CANTIDAD, EMPLAZAMIENTO Y CONTENIDO DE LOS SUMINISTROS MEDICOS.

BOTIQUIN DE PRIMEROS AUXILIOS

De acuerdo a NOM-012-SCT3-2012 (Modificación del 22-ago-2013)

DOTACIÓN REQUERIDA

MEDICAMENTO	DE ACUERDO A LA NORMA:
ABATELENGUAS (piezas	5 piezas
Butilhoscina (2 mg/ml) con paracetamol (100 mg/ml) gotas. Frasco con 20 ml.	1 frasco
Butilhoscina de 10 mg. (caja)	1 caja
COMPRESA FRIA	1 pieza
PARACETAMOL SOLUCIÓN 100 mg (frasco)	1 frasco
LOPERAMIDA TABLETAS 2 mg (caja)	1 caja
OXIMETAZOLINA SOLUCIÓN SPRAY (Solución nasal oximetazolina pediátrica)	1 frasco
ASPIRINA (ácido acetilsalicílico) TABLETA 500 MG	1 caja
CLORFENAMINA TABLETAS 4 MG	1 caja
DIFENIDOL (clorohidrato difenidol) TABLETAS 25MG	1 frasco
HIDRÓXIDO DE MAGNESIO TABLETAS 200 MG	1 caja
PARACETAMOL SOLUCIÓN 500 mg	1 caja
VENDA ELÁSTICA DE 10 X 5 CM	1 pieza de cada una
VENDA TRIÁNGULAR	1 pieza

DOTACIÓN SUGERIDA

MEDICAMENTO	DE ACUERDO A LA NORMA:
ALGODONES ANTISÉPTICOS PAQ. 50 PZAS.	Uno
CINTA ADHESIVA 1.2 CM X 4.6 CM MICROPORE	1 rollo
Formulario de registros de incidentes	1 pieza
PARES DE GUANTES DESECHABLES.	5 pares
MANUAL DE PRIMEROS AUXILIOS	1 pieza
MASCARILLA RCP	1 pieza de cada uno
PARCHE PARA OJOS	10 piezas
PERILLAS PARA ASPIRACIÓN (NÚMERO 0,1,2,3,4) 1 C/U	1 pieza de cada número
GEL ANTIBACTERIAL 60 ML	1 paquete
PINZAS MÉDICAS (CON DIENTES Y SIN DIENTES) 2 C/U	2 piezas de cada una
TIJERAS DE 10 CM	1 pieza
Termómetro (sin mercurio)	1 pieza
CAJA DE TIRAS ADHESIVAS (STERI STRIP DE 3 x 7.5 CM) (paq : 50 bolsas con 5 tiras)	1 paquete (50 bolsas con 5 tiras)
CAJA DE CINTAS ADHESIVAS DE 2.5 CM	1 caja
VENDAJE DE GASA DE 7.5CM x 4.5 CM	10 piezas
VENDAJE CON COMPRESA DE 7.5 CM x 12 CM	10 piezas
VENDAJE GASA ESTÉRIL DE 10.4 CM x 10.4 CM	10 piezas
VENDAJE DE 10 x 10 CM PARA QUEMADURAS	10 piezas